

DOOR-GARD™ FEATURES AND PROGRAMMING GUIDE

COMMAND AND CONTROL SERIES

DOOR-GARD COMMAND AND CONTROL SERIES keypads offer field proven reliability and cost effective solutions anywhere limited control or access is desired. Designed for individual control of up to four devices, Door-Gard Command and Control Series keypads are the perfect choice for controlling electric locking devices, security systems, automatic operators or machinery. Door-Gards accept power from a 12 or 24V AC/DC Supply.

FEATURES:

- 4 INDEPENDENT OUTPUTS
- 4 INDEPENDENT TIMERS
- ALL OUTPUTS ASSIGNABLE BY CODE
- ON BOARD 8 AMP FORM C RELAY
- 120 USERS
- REMOTE TRIGGERING INPUT
- KEYPAD PROGRAMMABLE

MEMORY

Non-volatile EEPROM memory means your codes and instructions will be there whether you remove power for 5 minutes or 5 years.

PROGRAMMING

All programming is accomplished entirely from the front of the keypad. LED or Sounder guidance makes programming easy, and changing codes a matter of seconds for an authorized user.

CODES

The Door-Gard Command and Control keypads allow up to 120 individual user codes to be valid. Codes may be from 1-6 digits in length and digits may be repeated. The **Master Code is always assigned to user location one (1).**

MAIN RELAY

This is an 8 Amp (10 Amp surge) Form-C relay which can be toggled or timed from 1 to 90 seconds-by code.

AUXILIARY OUTPUTS

Auxiliary outputs can be individually timed from 1 to 90 seconds or act as a toggle switch, and may be triggered individually or in combination-by code. The Ruggedized(r), Sealed Environmental (se), Multipad and Xtreme style provide these outputs in the form of 1 Amp Form-C relays, all other styles have negative voltage outputs with a 50mA sink.

REMOTE TRIGGERING INPUT (REX)

This normally open loop that by default operates the Main Relay upon activation and can be programmed to trigger any combination of outputs. Upon a momentary closure, the selected outputs will energize for their programmed time. The main relay (if selected) will energize for the same time period as the Master Code. This feature is especially useful when controlling an electric locking device.

KEYPRESS FEEDBACK / AUDIBLE KEYPRESS

The Command and Control Series Door-Gards will acknowledge a keypress by momentarily illuminating the yellow LED like on the indoor (i), or momentarily sounding the sounder like in the sealed environmental (se) style. This can be turned off through programming.

KEYPAD ACTIVE OUTPUT

The Command and Control Series Door-Gards can be programmed to energize a voltage output whenever a key is touched. This can be used to turn on accessories such as lights, CCTV camera, or notify a guard. This output is not available if the IEI 250 Printer Interface is used.

AUTO-ENTRY

This feature is used when the need for the code not to be followed by the * key is desired. The user only needs to enter their code number and the relay will activate for the programmed relay time. To use this feature, the user codes must be the same length as the master code.

AUDIT TRAIL *

An accurate real-time audit trail can be provided by any Command and Control Series Door-Gard with the addition of an optional model 250 Printer Interface. The 250 can monitor up to 8 keypads simultaneously. The 250 comes with power supply and printer cable and connects easily to any parallel line printer (not included).

** This option is not available with some styles of keypads. Call IEI for a list of product, or visit us on the web!*

1

TESTING THE KEYPAD

1. Connect the positive (+) lead of your power supply to the terminal strip (TS1) +V input.
2. Connect the negative (-) lead of your power supply to the terminal strip (TS1) -V input.
3. Turn on your power supply.
4. Press 7890#123456*. If all 12 keypresses have been verified, the keypad will enter self test mode. Either the LED's will flash or the sounder will beep 3 times, then light or sound continuously for 3 seconds (except on the mullion). If these responses do not happen, try the test mode again and then call tech support. **Note:** self test mode can be used when troubleshooting a keypad in the field. If you do not get the continuous light or sound then the memory has been corrupt and should be re-programmed with the 46 command (see option #19).
5. Enter the master code of 1234*. The relay will energize. Refer to programming section to program your keypad.

NOTE:

The keypad may be programmed in your shop or at the installation site. Programmed information is stored in non-volatile memory so it will not be lost if power is removed.

COMMAND AND CONTROL DEFAULTS

The Door-Gard Command and Control Series keypads are designed for easy installation in a minimum amount of time. The following defaults have been factory programmed.

| | |
|---------------------------------------|------------|
| Master Code (user 1) | 1234 |
| Main Relay will energize for | 5 seconds |
| Auxiliary Outputs will energize for | 5 seconds |
| Panic will energize | Output 4 |
| Keypad Active Output | Off |
| Remote Triggering Input will energize | Main Relay |
| Keypress Feedback | On |
| Led on when powered up | RED |
| Led on when relay is activated | GREEN |

If defaults must be changed or additional functions are desired, please refer to the *PROGRAMMING OPTIONS* chart after you are familiar with the *PROGRAMMING* section.

2

PROGRAMMING

1. Enter programming mode Yellow LED¹
Press 99 # (master code) * Flashes slowly
 2. To change master code²
Press 1 # (new master code) * Flashes fast
Repeat (new master code) * Flashes slowly
- If main relay time must be changed, substitute option 2 from PROGRAMMING OPTIONS CHART for step above.*
3. To add/change second code
Press 2 # (new user code) * Flashes fast
Repeat (new user code) * Flashes slowly
 4. To add/change third code
Press 3 # (new user code) * Flashes fast
Repeat (new user code) * Flashes slowly
 5. Up to 120 codes may be added in this fashion
 6. Exit programming mode
Press * Out

NOTES:

- User location represents one location in memory where an individual code is stored. A user code is stored in it's own user location. There are 120 user locations available.
- ¹ Some Door•Gard products contain a sounder in place of the yellow LED. In these products the flashing is replaced by a beeping.
- ² The master code is always in user location 1.
- The master code allows access to the programming mode & activates the main relay.
- All codes must be followed by the * key.
- Codes may be from 1-6 digits in length, and digits may be repeated.
- If the master code is forgotten or does not seem to be working, momentarily push SW1 on the circuit board, (see wiring diagram for location) to enter programming mode and follow step two from above to program a new master code.
- If the yellow LED lights (or sounder sounds) solid while in programming mode an error has occurred. Press * to clear (yellow LED should flash or sounder sound) and start over from step 2 or 3 above.

3

PROGRAMMING OPTIONS CHART

If the pre-programmed default values must be changed or additional functions are desired, the following options may be programmed.

| | | |
|--|----------------|--|
| 1. Enter programming mode | Press | 99 # (master code) * |
| 2. Change master code/set main relay time ¹ (SEE BELOW) <i>Example: Master code of 4321/relay time of 10 seconds</i> | Press Press | (Relay Time) # 1 # (new code) * (repeat code) * 10 # 1 # 4321 * 4321 * |
| 3. Add/change user code | Press | (user location) # (new code) * (repeat code) * |
| 4. Add/change user code with a different output time on main relay ¹ (SEE BELOW) | Press | (Relay Time) # (user location) # (new code) * (repeat code) * |
| 5. Delete user codes | Press | (user location) # * * |
| 6. Set output 2 time ¹ (SEE BELOW) | Press | 12 # (Relay Time) # 0 # * * |
| 7. Set output 3 time ¹ (SEE BELOW) | Press | 13 # (Relay Time) # 0 # * * |
| 8. Set output 4 time ¹ (SEE BELOW) | Press | 14 # (Relay Time) # 0 # * * |
| 9. Set outputs for Remote Triggering Input | Press | 17 # (outputs: .ie. 1, 2 or 2, 3 etc.) # 0 # * * Note: 0= no outputs |
| 10. Set outputs for Panic ² (SEE BELOW) | Press | 18 # (outputs: i.e. 1, 2 or 2, 3 etc.) # 0 # * * Note 0= no outputs |
| 11. Turn keypress feedback/audible keypress on | Press | 30 # 0 # 1 # * * |
| 12. Turn keypress feedback/audible keypress off | Press | 30 # 0 # 0 # * * |
| 13. Turn yellow LED/sounder on with relay | Press | 30 # 1 # 1 # * * |
| 14. Turn yellow LED/sounder off with relay | Press | 30 # 1 # 0 # * * |
| 15. Turn auto entry on | Press | 30 # 2 # 1 # * * |
| 16. Turn auto entry off | Press | 30 # 2 # 0 # * * |
| 17. Turn keypad active output on ³ (SEE BELOW) | Press | 43 # 0 # 99 # * * |
| 18. Turn keypad active off | Press | 43 # 0 # 00 # * * |
| 19. Erase keypad memory/reset defaults | Press | 46 # 00000 # 00000 # * * |
| 20. Energize selected output(s) with a user code ⁴ <i>Example: User 2; code of 4321*; energize outputs 2 & 3</i> | Press Press | 59 # (outputs: i.e. 1, 2 or 2, 3 etc.) # (user location) # (new code) * (repeat code) * 59 # 23 # 02# 4321 * 4321 * |

NOTES:

¹Relay time must always be represented by 2 digits. Example: 5 seconds = 05.
Latching /toggle is accomplished by entering a time of 00

²If selected, panic will operate by pressing the * and # simultaneously.
Panic operates for 1 second and is defaulted to output 4.

³Keypad active is a negative voltage output (sink) available on terminal (or wire) marked WB (see wiring diagrams for location).

⁴This feature is not available with the master code.

212 i/w Wiring Diagrams and Specifications

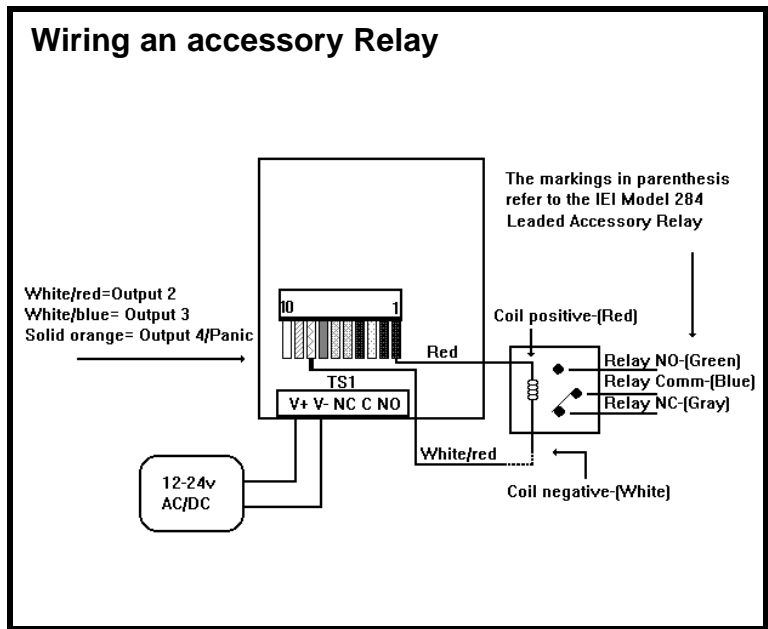
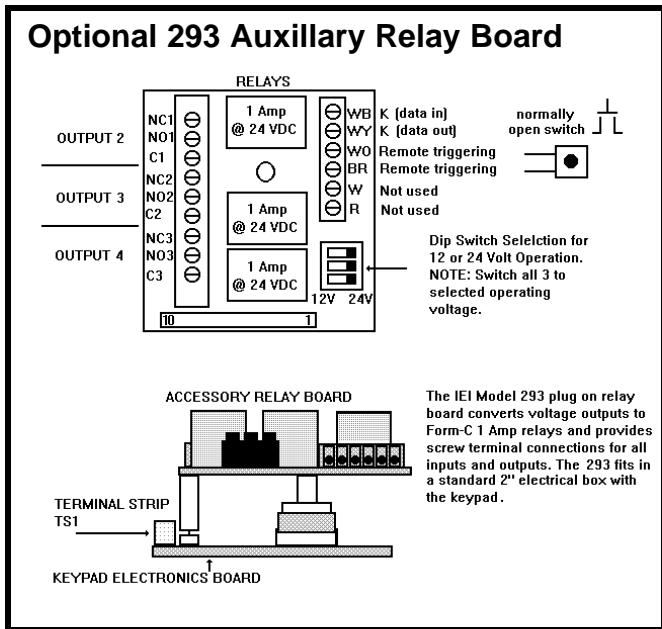
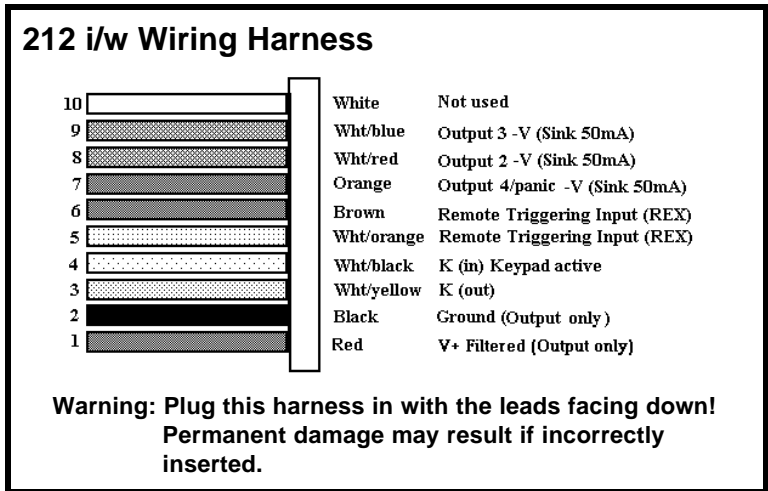
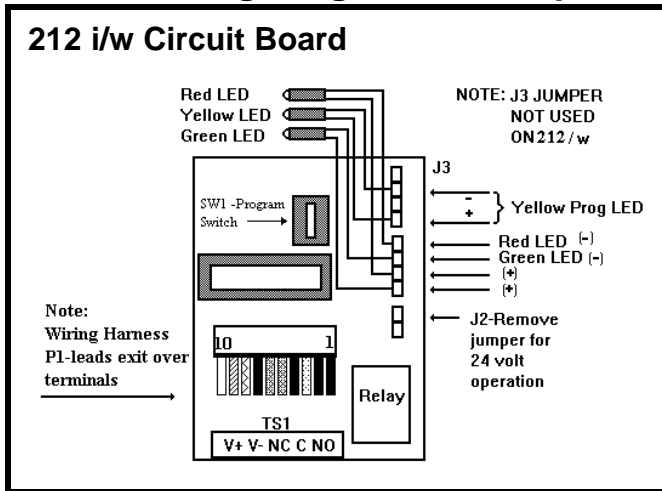

TECHNICAL NOTES

To avoid ESD (electro-static discharge) from interfering with the operation of the DOOR-GARD, ground the negative terminal of the keypad to earth ground. If the power supply can not be grounded, then the case should be grounded.

For use in extreme weather conditions, please consult the factory for additional methods of protecting your DOOR-GARD from the environment.

SPECIFICATIONS:

MECHANICAL:

BOARD DIMENSIONS:

1.70" w x 2.60" h x 1.125" d

1.70" w x 2.60" h x 1.675" d (w/ 293 relay board)

ELECTRICAL:

VOLTAGE:

12-24 Volts AC/DC (selected by jumper)

CURRENT:

@12vdc 4.5ma typical-36ma w/relay energized

@24vdc 6.2ma typical-38ma w/relay energized

Note: add 6ma per LED @ 12 volts/12ma @ 24 volts
Note: keypads using the IEI-293 relay board require an additional 30ma for each relay energized.

OUTPUTS:

Main relay: 8 Amp, Form-c @ 24VDC-10 AMP surge

Outputs 2, 3, & 4 are 50ma negative voltage outputs

ENVIRONMENTAL:

TEMPERATURE:

-20°F TO 130°F (-28°C TO 54°C)

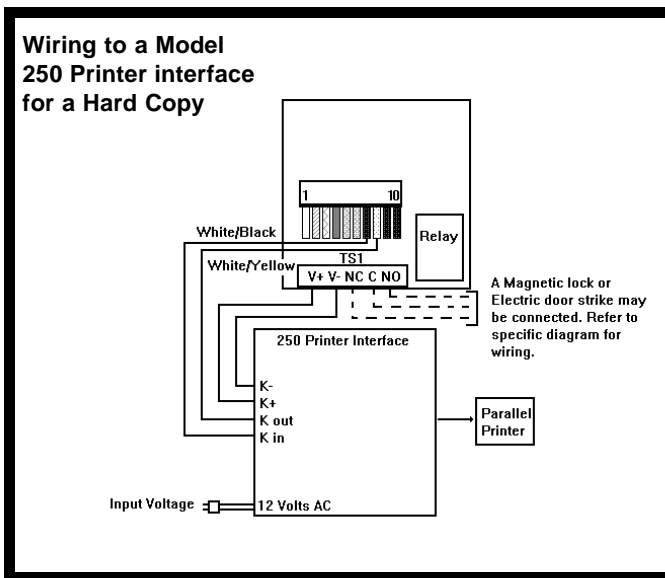
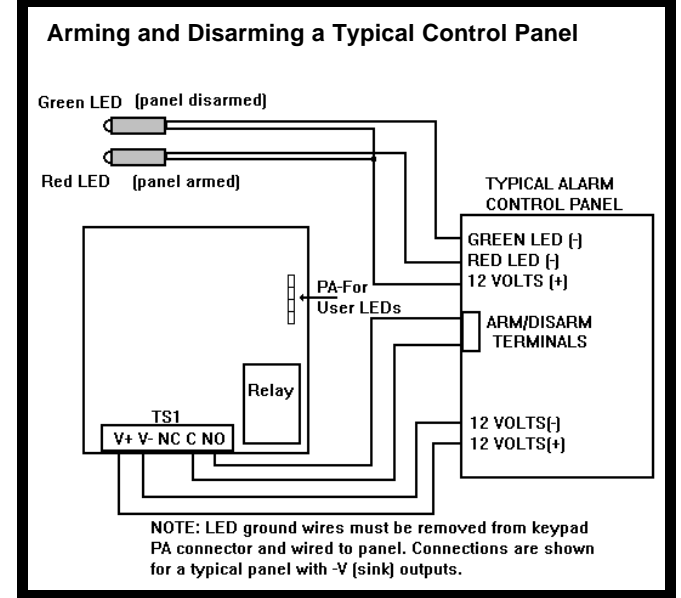
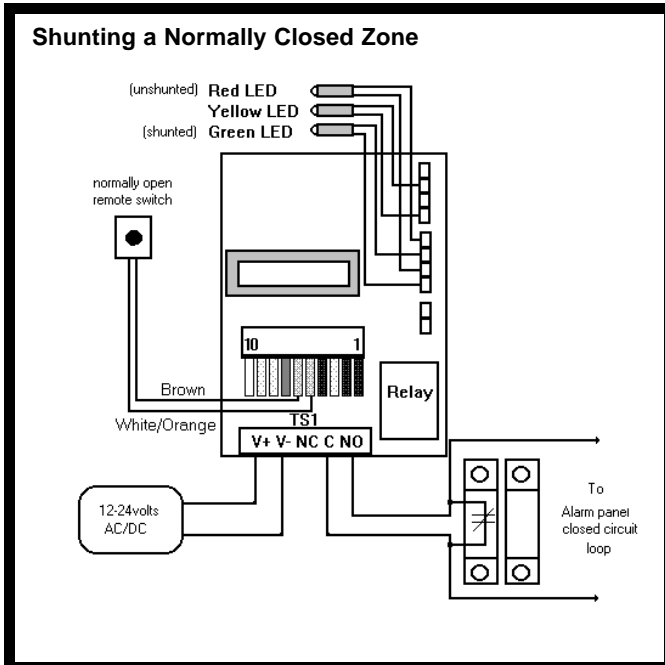
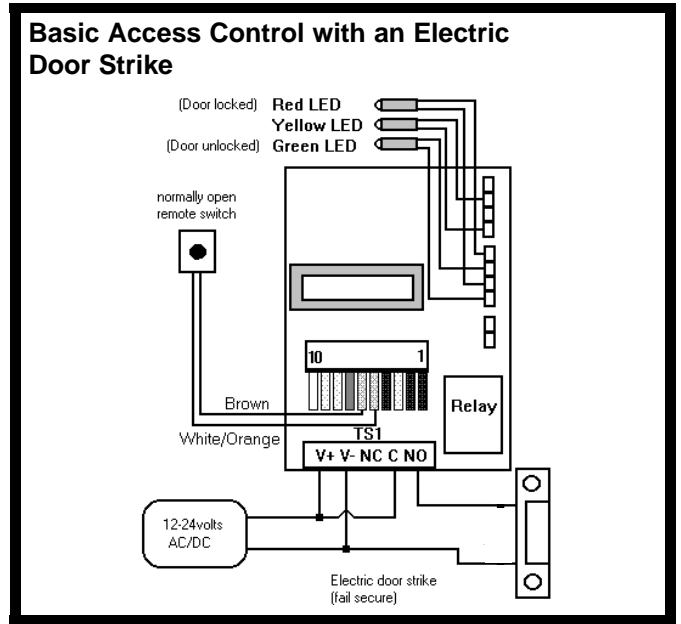
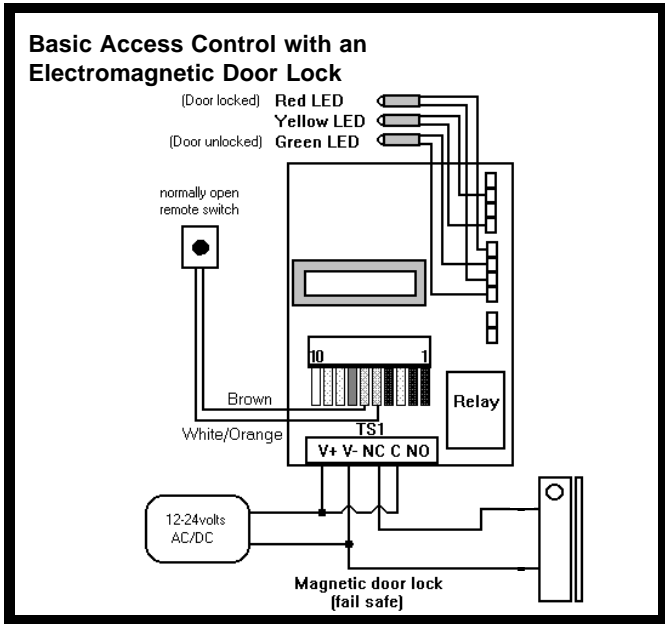

- PACKING CHECKLIST**
- 212i or 212w KEYPAD**
 - TEN CONDUCTOR WIRING HARNESS (1)**
 - SLOTTED SCREWS (2)**
 - SECURITY SCREWS (2)**
 - MOUNTING GASKET 212w ONLY (1)**
 - FEATURES AND PROGRAMMING GUIDE**
 - WARRANTY CARD**

COMMAND & CONTROL STYLES:

212i-INDOOR STYLE

- Flushmount indoor design.

212w-WEATHER RESISTANT STYLE

- Flushmount outdoor design.

212r-RUGGEDIZED STYLE

- Weatherproof self-contained metal housing.
- Vandal resistant.
- Cast metal housing suitable for wall, post or gooseneck mounting.
- Available in White or Black.
- 4 On-Board relays.

212se-SEALED ENVIRONMENTAL STYLE

- Weatherproof self-contained metal housing.
- Vandal resistant.
- Small design suitable for residential, commercial

and industrial applications.

- 4 On-Board relays.

212m-MULLION STYLE

- Weather resistant metal housing.
- Two-piece design with secured electronics.
- Narrow housing suitable for aluminum door frame mounting.
- Available in Bronze or Satin Aluminum

212mp MULTIPAD BACKLIT STYLE

- Weatherproof self contained housing.
- Illuminated keys.
- Contemporary design.
- 4 On-Board relays.

This list will change frequently. Be sure to check our web site!

ACCESSORIES:

DATA LOGGING

- IEI-250 PRINTER INTERFACE provides power, communication inputs and outputs for up to 8 Door• Gard Keypads. Interfaces with any parallel printer for user/door activity logging.

INSTALLATION

- IEI-280 WEATHERPROOF SURFACE BACK BOX.
- IEI-281 FLUSH MOUNT BACK BOX.
- IEI-290 12 VDC PLUG-IN POWER SUPPLY. 300MA.
- IEI-293 THREE RELAY PLUG-IN BOARD with FORM C, 1 amp relays.

Converts transistor outputs to dry contacts (for use with Command and Control indoor, weather resistant and mullion styles).

TAMPER PROTECTION

- IEI-282 TAMPER SWITCH detects faceplate removal.
- IEI-283 SECURITY MODULE responds to tamper switch (included) and cuts all in/out power to the door lock. Wires can't be crossed to unlock door. Must be reset from inside the protected area.
- IEI-289 TAMPER SCREWS - TRI-HEAD.
- IEI-267 1/4" DRIVER.
- IEI-270 ADAPTER SOCKET - TRI-HEAD.
- IEI-288 TAMPER SCREWS - ALLEN WITH PIN.
- IEI-271 TAMPER WRENCH - ALLEN WITH PIN.

OTHER DOOR-GARD PRODUCTS FROM IEI

CONTROL PANEL INTERFACE SERIES

- 210 – Programmable Keypad- Direct hardwire keyswitch replacement.
- 240 – Battery Operated Keypad- Direct keyswitch replacement (for indoor use).
- 262 – The Partitioner- Self-contained 2-zone control.

SELF-CONTAINED ACCESS CONTROL SYSTEMS

- 232i – Indoor keypad
- 232w – Weather-resistant
- 232se – Sealed environmental keypad
- 232r – Ruggedized keypad
- 232m – Mullion keypad
- 233 – Card Reader System
- 234 – Keypad/Card Reader System

FEATURING

- Lock Release Relay
- Lock Release Time
- Alarm Zone Shunting Relay
- Multiple User
- Propped Door Alarm Relay
- Timed Egress Input
- Forced Door Alarm Relay
- Front Programmable

If this product does not seem to operate properly, please call our Technical Department toll free at 1-800-343-9502 (781-821-5566) Monday -Friday 8:00 am-7:00 pm EST. We understand your time is valuable, and we know that calling our Technical Support Department will ensure that you'll make the most profit possible with your IEI product. Thank you for your purchase. We appreciate your business.

International Electronics, Inc. (IEI) warrants its products to be free from defects in material and workmanship, when they have been installed in accordance with the manufacturer's instructions, and have not been modified or tampered with. IEI does not assume any responsibility for damage or injury to person or property due to improper care, storage handling, abuse, misuse, normal wear and tear, or an act of God.

IEI's sole responsibility is limited to the repair (at IEI's option) the replacement of the defective product or part when sent to IEI's facility (freight and insurance charges prepaid), after obtaining IEI's Return Merchandise Authorization. IEI will not be liable to the purchaser or any one else for incidental or consequential damages arising from any defect in, or malfunction of, its products.

This warranty shall expire two years after shipping date. Except as stated above, IEI makes no warranties, either express or implied, as to any matter whatsoever, including, without limitation to, the condition of its products, their merchantability, or fitness for any particular reason.

ALPHA COMMUNICATIONS - 42 Central Drive, Farmingdale NY 11735-1202

Phone: 631-777-5500 Fax: 631-777-5599
TOLL-FREE Technical Line 1-800-666-4800
Email: info@alpha-comm.com

MADE IN U.S.A.
605-0212
REV. 1.04

www.intercoms.com