

INSTALLATION MANUAL

Auth-Florence 4C Horizontal Mailbox Systems
(ALL TYPES)

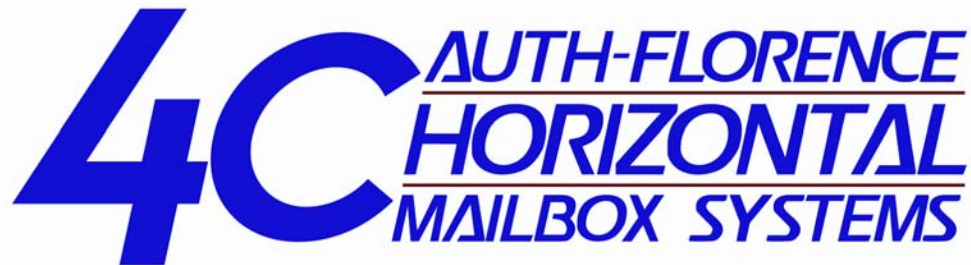

TABLE OF CONTENTS

INSTALLATION AND SETUP	PAGE
<i>INSTALLATION REQUIREMENTS AND GENERAL INFORMATION</i>	2
<i>PARCEL DOOR ONLY UNIT FUNCTIONALITY AND INSTALLATION INFORMATION</i>	3
<i>INDEPENDENT INSTALLATION</i>	5
<i>MULTIPLE INSTALLATION USING Auth-Florence's EXCLUSIVE MULTI-UNIT CONNECTOR KIT</i>	7
<i>INSTALLATION OF COLLECTION DOOR ARROW LOCK (by U.S.P.S.)</i>	11
<i>INSTALLATION OF PARCEL DOOR ARROW LOCK (by U.S.P.S.)</i>	13
APPENDIX	-
<i>INDEPENDENT INSTALLATION WALL CONSTRUCTION</i>	15

Distributed by: *Alpha Communications*[®]

42 Central Drive, Farmingdale NY 11735-1202

www.alpha-comm.com

*Ph. 800-666-4800
Fax. 631-777-5599*

Auth/Florence...YOUR ISO 9001 MAILBOX SUPPLIER



© 2006, Florence Corporation.

INSTALLATION REQUIREMENTS AND GENERAL INFORMATION

FOR Auth-Florence 4C Horizontal Mailbox Systems



USPS INSTALLATION REQUIREMENTS:

1. AT LEAST ONE CUSTOMER COMPARTMENT SHALL BE POSITIONED LESS THAN 48" FROM THE FINISHED FLOOR.
2. NO PARCEL LOCKER COMPARTMENT (INTERIOR BOTTOM SHELF) SHALL BE POSITIONED LESS THAN 15" FROM THE FINISHED FLOOR.
3. NO PATRON (TENANT) LOCK SHALL BE LOCATED MORE THAN 67" ABOVE THE FINISHED FLOOR.
4. NO CUSTOMER COMPARTMENT (INTERIOR BOTTOM SHELF) SHALL BE POSITIONED LESS THAN 28" FROM THE FINISHED FLOOR.
5. THE USPS ARROW LOCK SHALL BE LOCATED BETWEEN 36" AND 48" ABOVE THE FINISHED FLOOR.

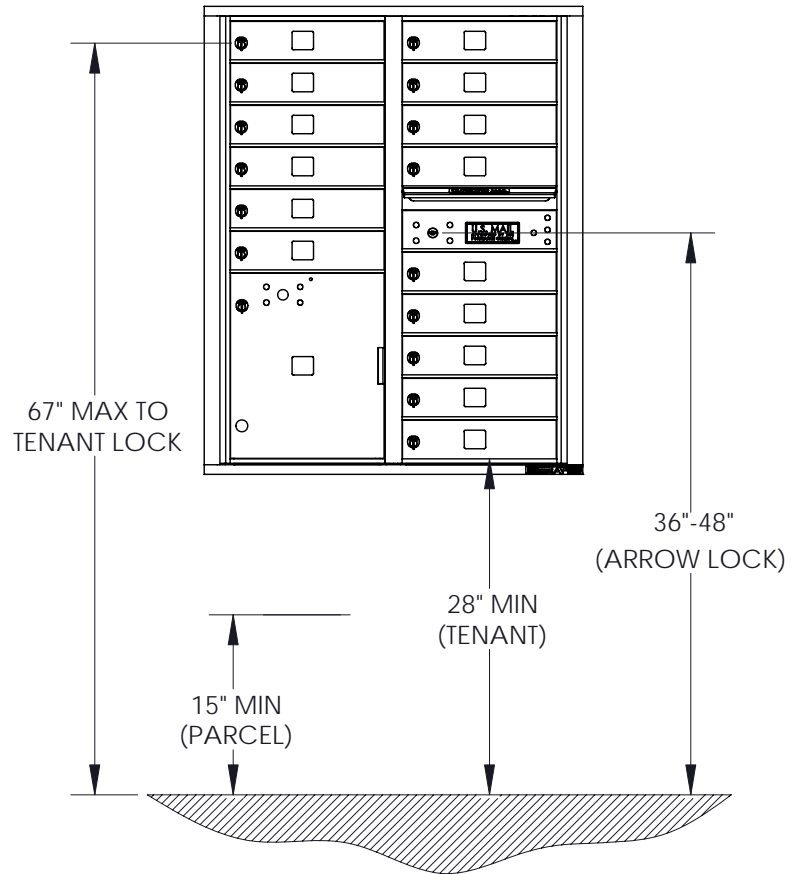

CAUTION - handling & transportation

- LAY BOXES FLAT, DO NOT STAND ON END. BOX COULD FALL OVER AND CAUSE INJURY.
- BOXES ARE HEAVY. USE CAUTION WHEN LIFTING AND CARRYING TO AVOID INJURY.

CAUTION - installation

- Auth-Florence 4C UNITS ARE HEAVY. USE CAUTION WHEN LIFTING AND CARRYING TO AVOID INJURY.
- A PINCH HAZARD EXISTS WHEN PLACING THE MAILBOX IN ROUGH OPENING. KEEP FINGERS AND HANDS CLEAR TO AVOID AN INJURY.

WARNING - installation

- Auth-Florence 4C UNITS ARE FRONT-HEAVY. DO NOT STAND ON END WITHOUT SUPPORT TO PREVENT TIPPING. MAILBOXES MAY TIP OUT OF ROUGH OPENING UNTIL SECURED, POSSIBLY RESULTING IN THE MAILBOX COLLIDING WITH A PERSON AND CAUSING SERIOUS INJURY.
- Auth-Florence 4C UNITS ARE VERY FRONT-HEAVY WITH MASTER LOADING DOORS OPEN. UNITS MUST BE BRACED OR HELD IN PLACE UNTIL SECURED TO FRAMING. INSTALLER SHOULD SUPPORT UNIT OR HAVE ASSISTANCE HOLDING THE UNIT IN PLACE BEFORE OPENING THE MASTER LOAD DOORS. FAILURE TO DO SO COULD RESULT IN SERIOUS INJURY.

THE NEW U.S. POSTAL SERVICE STD-4C INCLUDES THE FOLLOWING SPECIFICATIONS:

- A NEW COMPARTMENT FORM FACTOR MINIMUM SIZE REQUIREMENT OF 12"W x 15"D x 3"H.
- ELIMINATES THE VERTICAL FORM FACTOR (5"W x 6"D x 15"H) DESIGN.
- INTRODUCES A PARCEL LOCKER REQUIREMENT BASED ON A 1:10 PARCEL LOCKER TO CUSTOMER COMPARTMENT RATIO.
- STRENGTHENS SECURITY REQUIREMENTS FOR THE ENTIRE RECEPTACLE.
- STANDARDIZES AND IMPROVES TENANT COMPARTMENT LOCK DESIGN.
- ADDS TESTING REQUIREMENTS TO VERIFY ACCEPTABILITY FOR EITHER INDOOR OR OUTDOOR USE.
- INTRODUCES QUALITY MANAGEMENT SYSTEMS PROVISIONS.
- ENHANCES DESIGN FLEXIBILITY FOR CONCEPT, ERGONOMICS, AND MATERIALS.
- MEETS AMERICANS WITH DISABILITIES ACT (ADA) STANDARDS.

Auth-Florence 4C HORIZONTAL MAILBOX SYSTEMS ARE DESIGNED TO MEET OR EXCEED THE U.S.P.S. SPECIFICATIONS OUTLINED ABOVE AND IN THE FEDERAL REGISTER/VOL. 69 NO. 171/SEPTEMBER 3, 2004/RULES AND REGULATIONS POSTAL SERVICE, 39 CFR PART 111, STANDARDS GOVERNING THE DESIGN OF WALL-MOUNTED CENTRALIZED MAIL RECEPTACLES. PROPER INSTALLATION IS THE RESPONSIBILITY OF THE INSTALLER. THE INSTALLATION REQUIREMENTS LISTED HEREIN ARE BASED ON THE U.S.P.S. THE FEDERAL REGISTER PREVIOUSLY MENTIONED.

PARCEL DOOR ONLY UNIT FUNCTIONALITY AND INSTALLATION INFORMATION

Auth-Florence 4C Horizontal Mailbox Systems (PARCEL ONLY UNIT)

1. PREPARING FOR INSTALLATION: (PARCEL DOOR ONLY UNITS)

- WHILE LOOKING AT THE BACK OF THE UNIT, SLIDE AND HOLD THE LATCH PLATE UP PAST THE LATCH HOOK AS ILLUSTRATED.
- THE FRONT OF THE UNIT CAN NOW BE OPENED TO GAIN ACCESS TO MOUNTING SCREW HOLES/SLOTS FOR INSTALLATION. REMOVE ALL HARDWARE LOCATED INSIDE THE UNIT AND SET ASIDE.
- PLACE PARCEL UNIT IN OPENING AS SHOWN IN "INDEPENDENT INSTALLATION" OR "MULTIPLE INSTALLATION" AS REQUIRED AND PROCEED WITH INSTALLATION.

2. WHEN INSTALLATION IS COMPLETE, CLOSE THE FRONT OF THE UNIT. MAKE SURE YOU HAVE REMOVED ALL HARDWARE LOCATED INSIDE THE UNIT.

- OPEN PARCEL DOORS USING PARCEL DOOR KEYS INCLUDED WITH HARDWARE.
- INSTALL BOTH 64256 SLIDE LOCKS USING 84994 10-32 X .375" ONE WAY SCREWS.

NOTE:

IF ACCESS TO MOUNTING SCREWS IS NECESSARY FOR ADJUSTMENT OR MAINTENANCE, OPEN PARCEL DOORS, REMOVE 84994 10-32 X .375" ONE WAY SCREWS AND 64256 SLIDE LOCKS. DISENGAGE LATCH PLATE BY PLACING A SMALL ALLEN WRENCH (HEX KEY) IN THE SLIDE LOCK SLOT AND SLIDE LATCH PLATE UP. THE FRONT OF THE UNIT CAN NOW BE OPENED.

REQUIRED TOOLS
SLOTTED SCREW DRIVER

PART #	DESCRIPTION
64256	SLIDE LOCK
84944	#10-32 X .375" ONE WAY SCREW

PARCEL DOOR ONLY UNIT FUNCTIONALITY AND INSTALLATION INFORMATION (cont...)

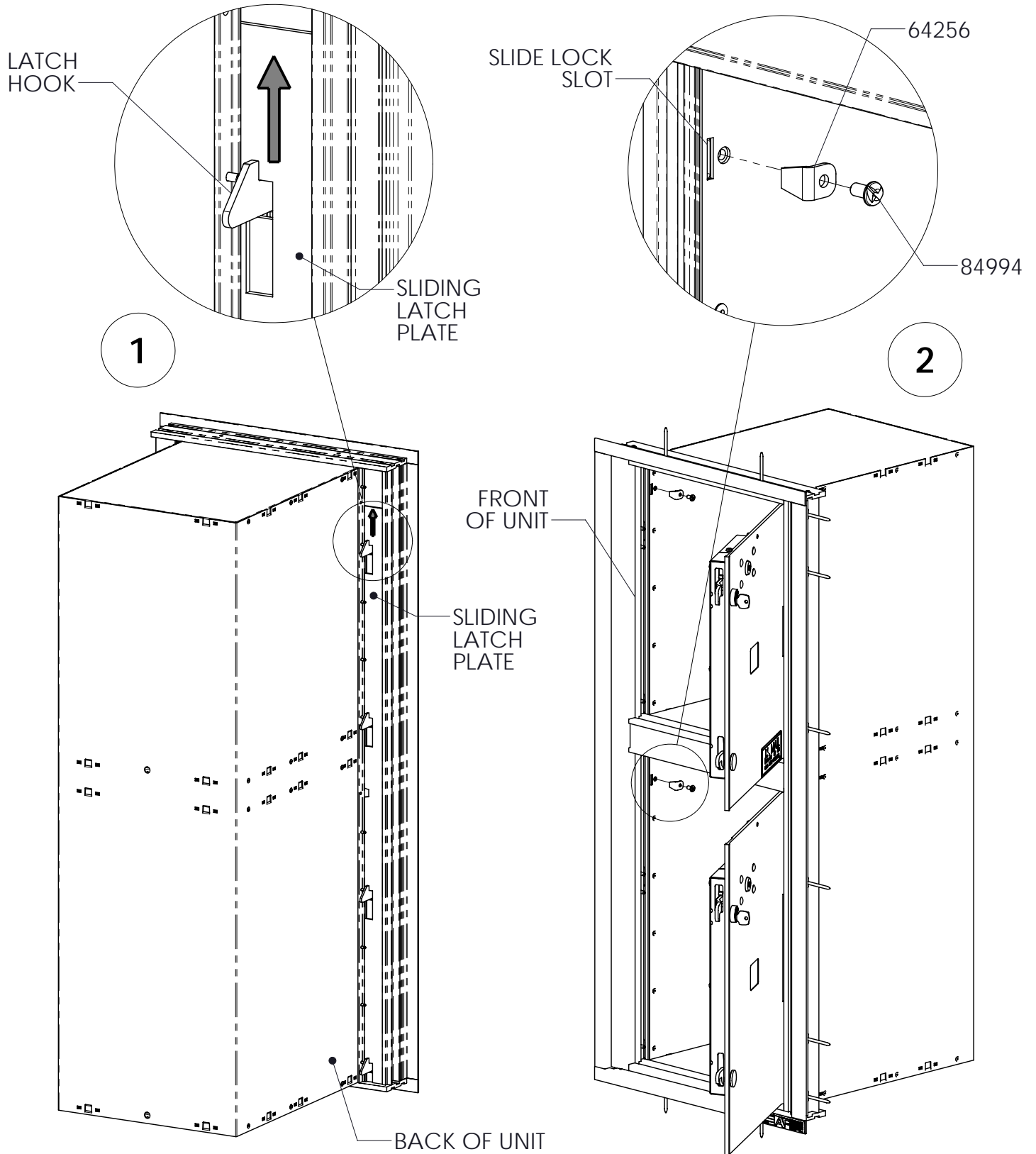

INDEPENDENT INSTALLATION

Auth-Florence 4C Horizontal Mailbox Systems (FRONT LOADING)

1. PLACE Auth-Florence 4C UNIT IN OPENING UNTIL INTEGRATED TRIM IS FLUSH WITH WALL BOARD. (SEE PAGE 3 FOR ADDITIONAL INSTALLATION INFORMATION NEEDED FOR PARCEL ONLY UNITS)

2. FOR DOUBLE COLUMN Auth-Florence 4C UNITS:

- OPEN RIGHT MASTER LOAD DOOR UNTIL HOLD OPEN ARM ENGAGES AND INSTALL INCLUDED 64225 MOUNTING SCREWS ALONG RIGHT HAND OUTER FRAME MEMBER.
- PARTIALLY OPEN LEFT MASTER LOAD DOOR UNTIL RIGHT MASTER LOAD DOOR CAN BE COMPLETELY CLOSED.
- OPEN LEFT MASTER LOAD DOOR UNTIL HOLD OPEN ARM ENGAGES AND INSTALL INCLUDED 64225 MOUNTING SCREWS ALONG LEFT HAND OUTER FRAME MEMBER.
- WITH BOTH LEFT AND RIGHT MASTER LOAD DOORS OPEN AND HOLD OPEN ARMS ENGAGED, INSTALL INCLUDED 64225 MOUNTING SCREWS ALONG TOP AND BOTTOM FRAME MEMBERS.
- Auth-Florence 4C UNIT IS NOW INSTALLED.

2a. FOR SINGLE COLUMN Auth-Florence 4C UNITS:

- OPEN MASTER LOAD DOOR UNTIL HOLD OPEN ARM ENGAGES AND INSTALL INCLUDED 64225 MOUNTING SCREWS ALONG BOTH LEFT AND RIGHT HAND OUTER FRAME MEMBERS.
- WITH MASTER LOAD DOOR OPEN AND HOLD OPEN ARM ENGAGED, INSTALL INCLUDED 64225 MOUNTING SCREWS ALONG TOP AND BOTTOM FRAME MEMBERS.
- Auth-Florence 4C UNIT IS NOW INSTALLED.

REQUIRED TOOLS
3/8" DRILL (PREFERABLY CORDLESS)
T20 TORX BIT & BIT TIP HOLDER

PART #	DESCRIPTION
64225	WOOD SCREW, #8 X 2", T20 TORX DRIVE (MOUNTING SCREW)

INDEPENDENT 4C INSTALLATION

(cont...)

! CAUTION - installation

- Auth-Florence 4C UNITS ARE HEAVY. USE CAUTION WHEN LIFTING AND CARRYING TO AVOID INJURY.
- A PINCH HAZARD EXISTS WHEN PLACING THE MAILBOX IN ROUGH OPENING. KEEP FINGERS AND HANDS CLEAR TO AVOID AN INJURY.

! WARNING - installation

- Auth-Florence 4C UNITS ARE FRONT-HEAVY. DO NOT STAND ON END WITHOUT SUPPORT TO PREVENT TIPPING. MAILBOXES MAY TIP OUT OF ROUGH OPENING UNTIL SECURED, POSSIBLY RESULTING IN THE MAILBOX COLLIDING WITH A PERSON AND CAUSING SERIOUS INJURY.
- Auth-Florence 4C UNITS ARE VERY FRONT-HEAVY WITH MASTER LOADING DOORS OPEN. UNITS MUST BE BRACED OR HELD IN PLACE UNTIL SECURED TO FRAMING. INSTALLER SHOULD SUPPORT UNIT OR HAVE ASSISTANCE HOLDING THE UNIT IN PLACE BEFORE OPENING THE MASTER LOAD DOORS. FAILURE TO DO SO COULD RESULT IN SERIOUS INJURY.

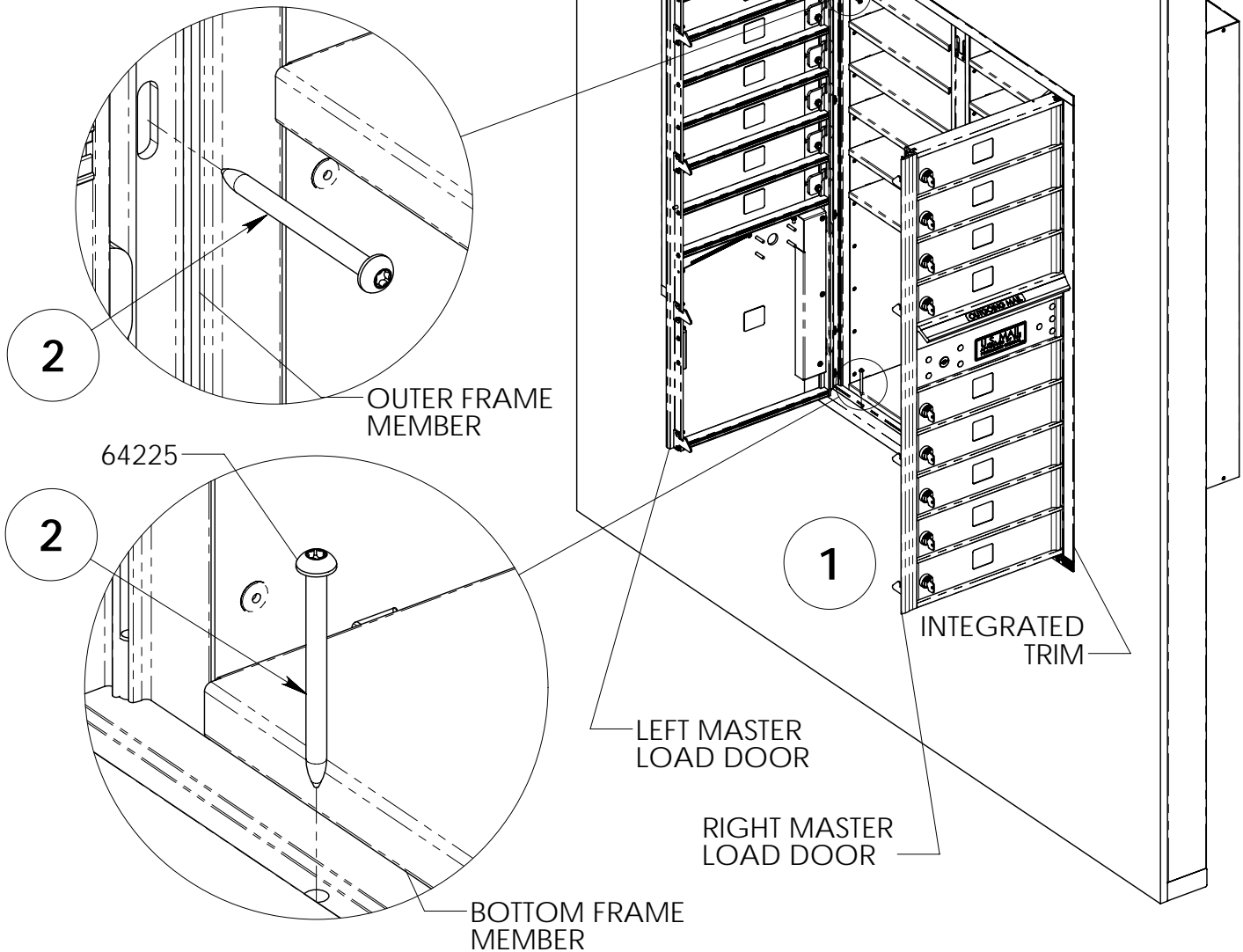

NOTE:

64225 #8x2" LONG WOOD SCREWS SHOULD BE TIGHTENED TO ASSURE A SNUG FIT. HOWEVER, OVERTIGHTENING BEYOND INITIAL CONTACT WITH FRAME COULD HINDER FUNCTIONALITY. IF OVERTIGHTENING OCCURS SIMPLY BACK OUT EACH OVERTIGHTENED MOUNTING SCREW.

MULTIPLE INSTALLATION USING Auth-Florence's EXCLUSIVE MULTI-UNIT CONNECTOR KIT (PATENT PENDING)

Auth-Florence 4C Horizontal Mailbox Systems (FRONT LOADING)

1. PLACE THE FIRST UNIT AT THE RIGHT HAND SIDE OF THE ROUGH OPENING UNTIL INTEGRATED TRIM IS FLUSH WITH WALL BOARD.

2. OPEN MASTER LOAD DOOR(S) UNTIL HOLD OPEN ARM ENGAGES AND INSTALL INCLUDED 64225 MOUNTING SCREWS ALONG RIGHT HAND OUTER FRAME MEMBER.

3. OPEN MASTER LOAD DOOR(S) UNTIL HOLD OPEN ARM ENGAGES, INSTALL INCLUDED 64225 MOUNTING SCREWS ALONG TOP AND BOTTOM FRAME MEMBERS.

4. FASTEN MULTI-UNIT CONNECTOR TO THE UNIT USING INCLUDED 91123 SCREWS.

5. PLACE NEXT UNIT IN OPENING UNTIL INTEGRATED TRIM IS FLUSH WITH WALL BOARD. SLIDE UNIT TO RIGHT UNTIL TRIM IS AGAINST PREVIOUSLY INSTALLED UNIT.

6. INSTALL INCLUDED 91123 SCREWS ALONG RIGHT HAND OUTER FRAME MEMBER.

7. OPEN MASTER LOAD DOOR(S) UNTIL HOLD OPEN ARM ENGAGES, INSTALL INCLUDED 64225 MOUNTING SCREWS ALONG TOP AND BOTTOM FRAME MEMBERS.

8. REPEAT STEPS 3 THROUGH 7 FOR ANY ADDITIONAL UNITS THAT WILL BE MOUNTED TO A MULTI-UNIT CONNECTOR.

9. OPEN MASTER LOAD DOOR(S) UNTIL HOLD OPEN ARM ENGAGES AND INSTALL INCLUDED 64225 MOUNTING SCREWS ALONG LEFT HAND OUTER FRAME MEMBER.

REQUIRED TOOLS
3/8" DRILL (PREFERABLY CORDLESS)
T20 TORX BIT & BIT TIP HOLDER

PART #	DESCRIPTION
64225	WOOD SCREW, #8 X 2", T20 TORX DRIVE (MOUNTING SCREW)
VARIES	MULTI-UNIT CONNECTOR
91123	SELF TAPPING SCREW, T20 TORX DRIVE

MULTIPLE INSTALLATION USING Auth-Florence's EXCLUSIVE MULTI-UNIT CONNECTOR KIT

(cont...)

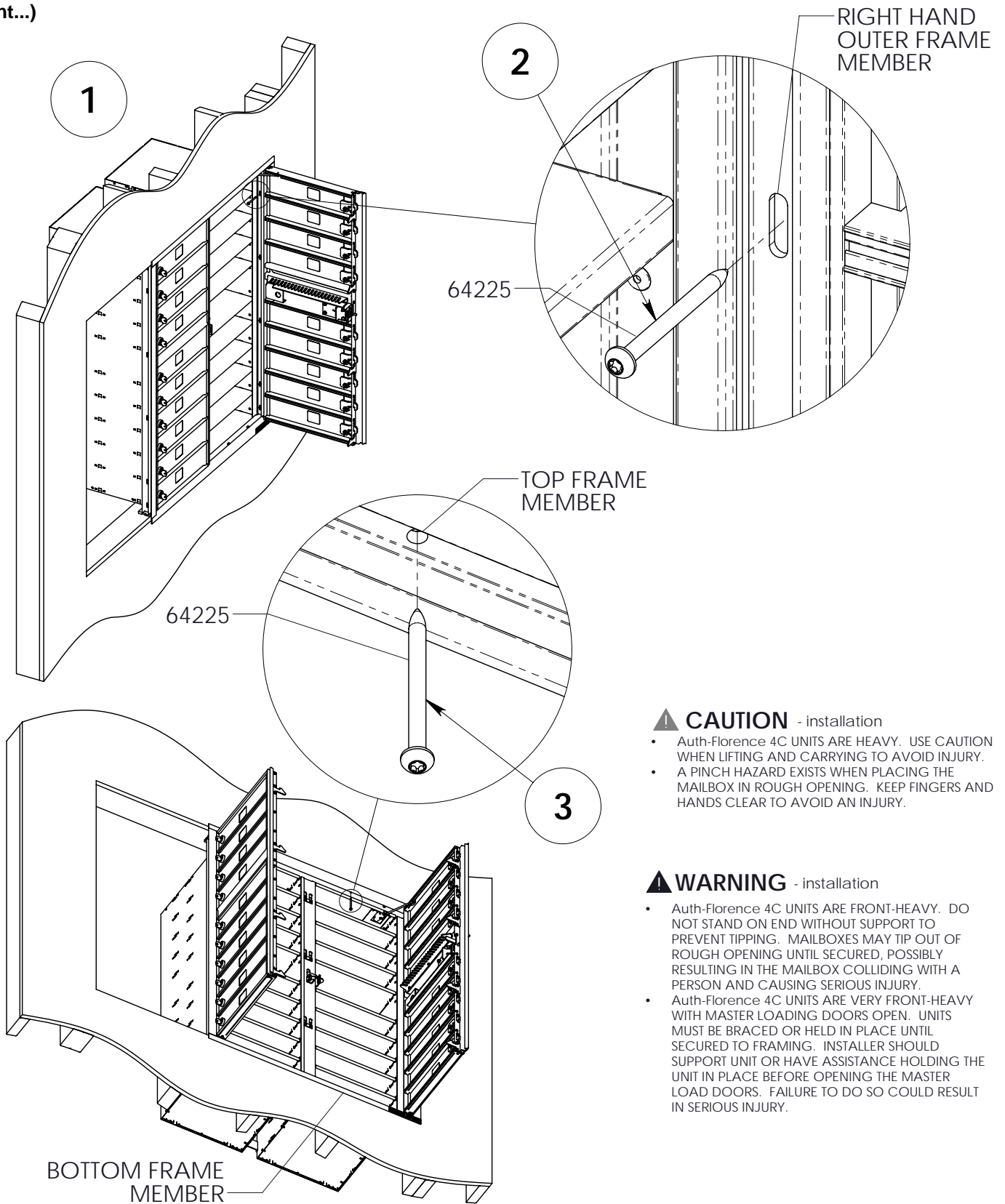

▲ CAUTION - installation

- Auth-Florence 4C UNITS ARE HEAVY. USE CAUTION WHEN LIFTING AND CARRYING TO AVOID INJURY.
- A PINCH HAZARD EXISTS WHEN PLACING THE MAILBOX IN ROUGH OPENING. KEEP FINGERS AND HANDS CLEAR TO AVOID AN INJURY.

▲ WARNING - installation

- Auth-Florence 4C UNITS ARE FRONT-HEAVY. DO NOT STAND ON END WITHOUT SUPPORT TO PREVENT TIPPING. MAILBOXES MAY TIP OUT OF ROUGH OPENING UNTIL SECURED, POSSIBLY RESULTING IN THE MAILBOX COLLIDING WITH A PERSON AND CAUSING SERIOUS INJURY.
- Auth-Florence 4C UNITS ARE VERY FRONT-HEAVY WITH MASTER LOADING DOORS OPEN. UNITS MUST BE BRACED OR HELD IN PLACE UNTIL SECURED TO FRAMING. INSTALLER SHOULD SUPPORT UNIT OR HAVE ASSISTANCE HOLDING THE UNIT IN PLACE BEFORE OPENING THE MASTER LOAD DOORS. FAILURE TO DO SO COULD RESULT IN SERIOUS INJURY.

NOTE:

64225 #8x2" LONG WOOD SCREWS SHOULD BE TIGHTENED TO ASSURE A SNUG FIT. HOWEVER, OVERTIGHTENING BEYOND INITIAL CONTACT WITH FRAME COULD HINDER FUNCTIONALITY. IF OVERTIGHTENING OCCURS SIMPLY BACK OUT EACH OVERTIGHTENED MOUNTING SCREW.

MULTIPLE INSTALLATION USING Auth-Florence's EXCLUSIVE MULTI-UNIT CONNECTOR KIT

(cont...)

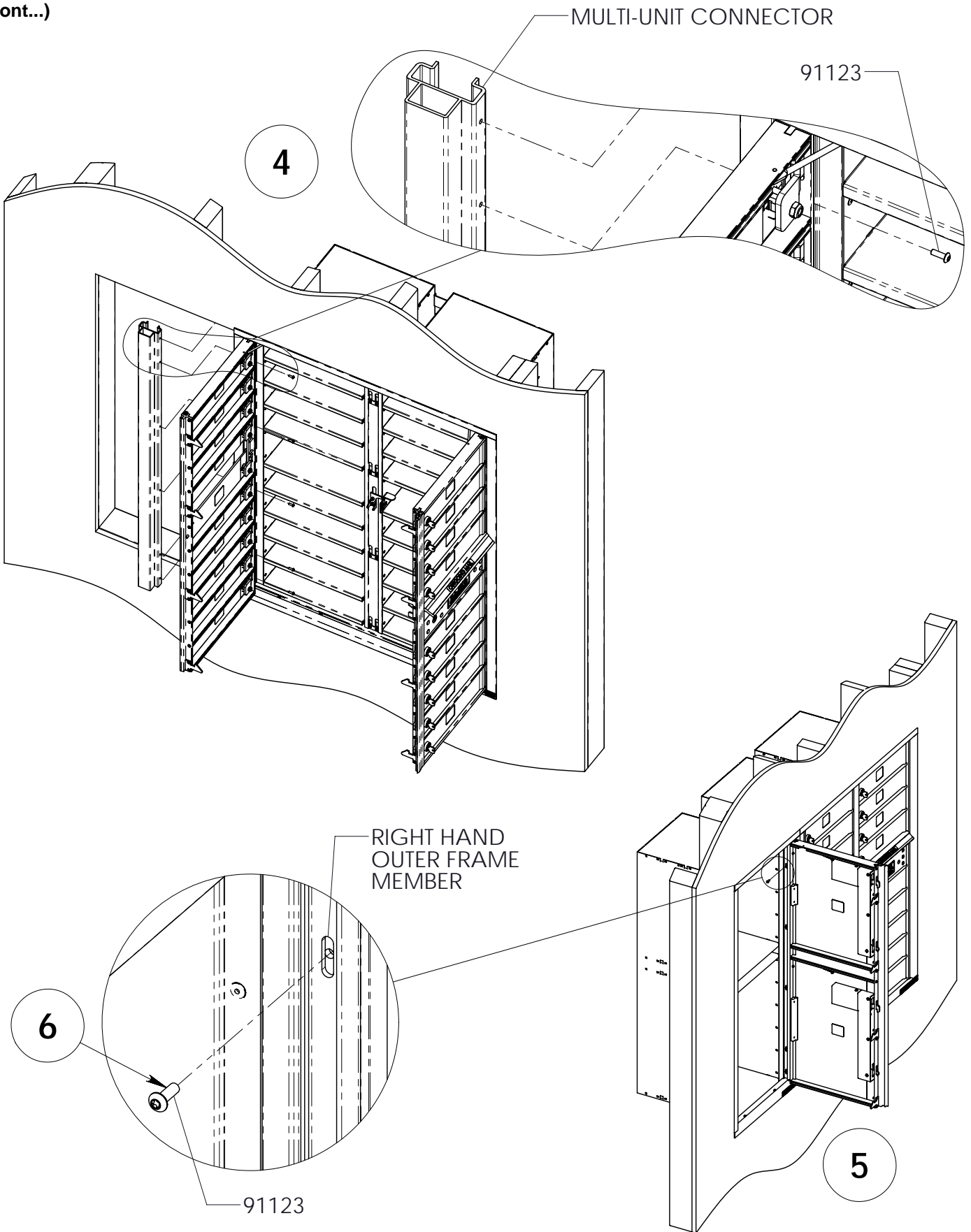

MULTIPLE INSTALLATION USING Auth-Florence's EXCLUSIVE MULTI-UNIT CONNECTOR KIT

(cont...)

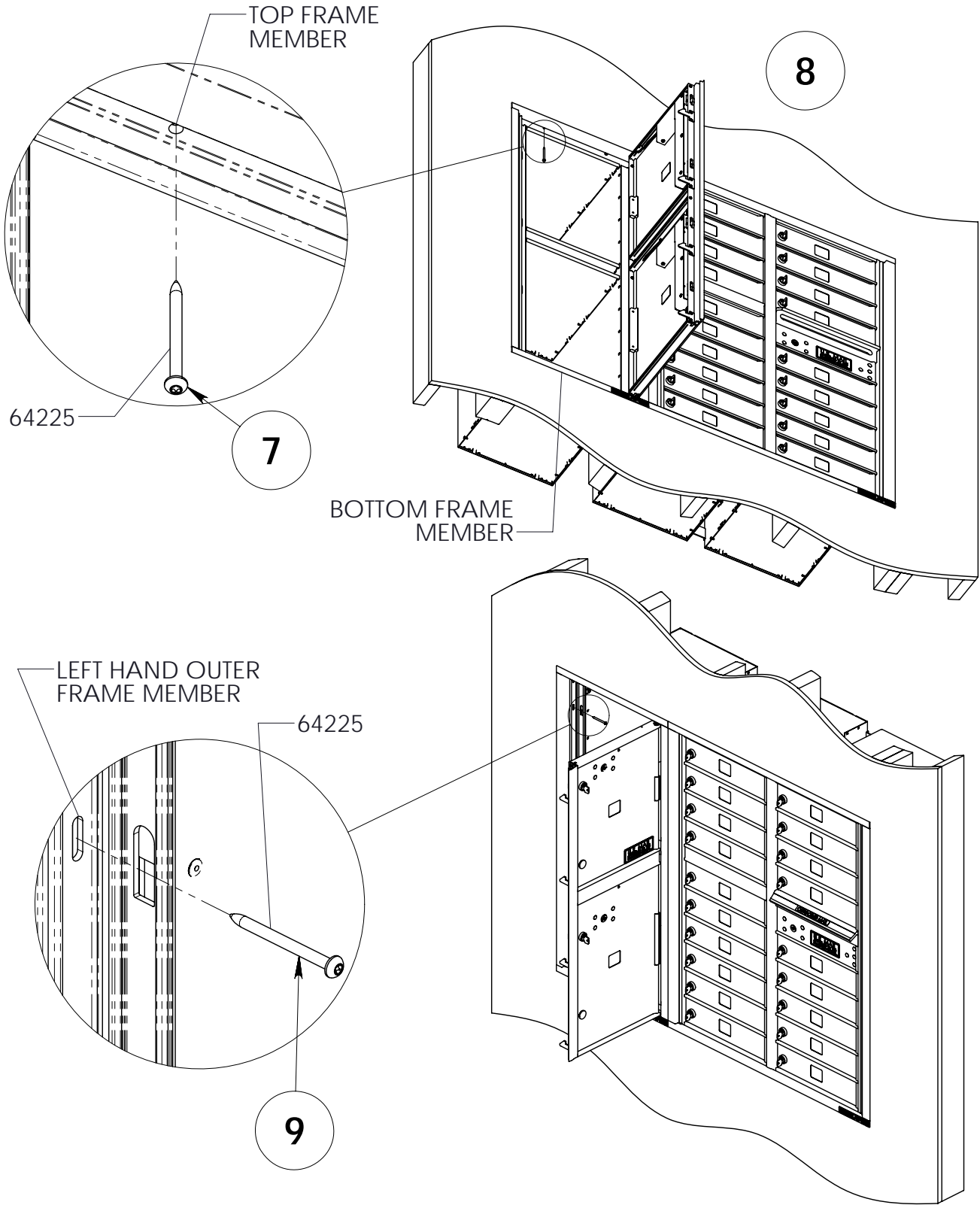

NOTE:

64225 #8x2" LONG WOOD SCREWS SHOULD BE TIGHTENED TO ASSURE A SNUG FIT. HOWEVER, OVERTIGHTENING BEYOND INITIAL CONTACT WITH FRAME COULD HINDER FUNCTIONALITY. IF OVERTIGHTENING OCCURS SIMPLY BACK OUT EACH OVERTIGHTENED MOUNTING SCREW.

INSTALLATION OF COLLECTION DOOR ARROW LOCK

Auth-Florence 4C Horizontal Mail Systems (FRONT LOADING)

NOTE:

**ARROW LOCK INSTALLED BY U.S. POSTAL SERVICE PERSONNEL ONLY.
CONTACT YOUR LOCAL POST OFFICE TO ARRANGE INSTALLATION OF
ARROW LOCK.**

1. INSERT ARROW LOCK INTO 92300 PLATE ASSY.-HS ARROW LOCK AS SHOWN.

2. WITH THE COLLECTION DOOR OPEN, SLIDE 92300 PLATE ASSY.-HS ARROW LOCK WITH ARROW LOCK ONTO THE COLLECTION DOOR BOLTS.

3. INSTALL 92303 PLATE-LOCK SUPPORT AS ORIENTED IN THE ILLUSTRATION.

4. INSTALL FIVE (5) 86091 10-32 LOCK NUTS. THESE NUTS SHOULD BE TIGHTENED TO ASSURE A SNUG FIT. OVERTIGHTENING MAY KEEP ARROW LOCK FROM OPERATING CORRECTLY.

REQUIRED TOOLS
3/8" SOCKET WRENCH OR NUT DRIVER

PART #	DESCRIPTION
92300	PLATE ASSY.-HS ARROW LOCK
92303	PLATE-LOCK SUPPORT
86091	10-32 LOCK NUTS
N/A	ARROW LOCK (PROVIDED BY U.S.P.S)

INSTALLATION OF COLLECTION DOOR ARROW LOCK (FOR U.S.P.S PERSONNEL ONLY) (cont...)

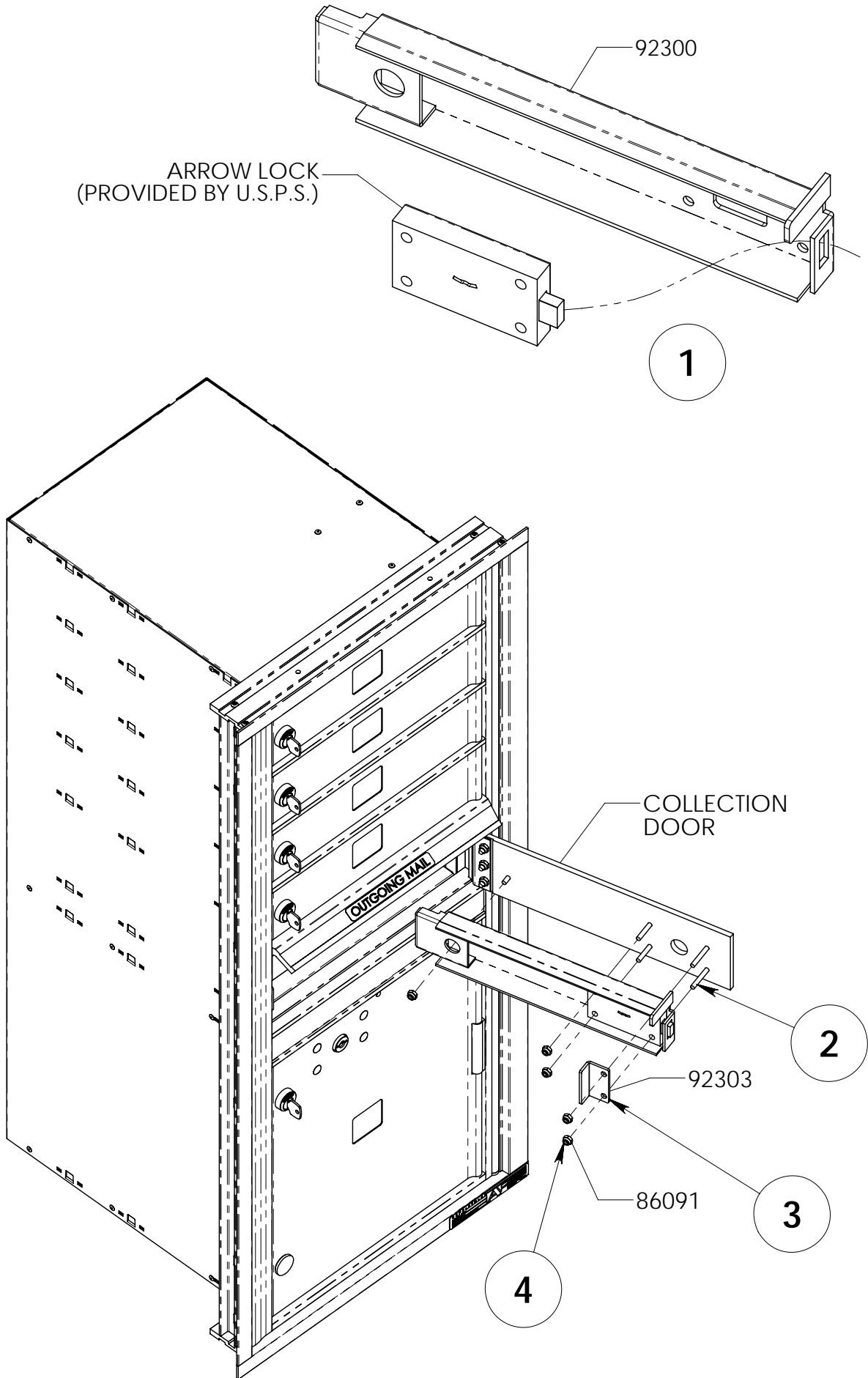

PARCEL DOOR ARROW LOCK INSTALLATION

Auth-Florence 4C Horizontal Mailbox Systems (ALL TYPES)

NOTE:

**ARROW LOCK INSTALLED BY U.S. POSTAL SERVICE PERSONNEL ONLY.
CONTACT YOUR LOCAL POST OFFICE TO ARRANGE INSTALLATION OF
ARROW LOCK.**

1. OPEN PARCEL DOOR AND LOCK PARCEL DOOR CUSTOMER LOCK. NOTE: PARCEL DOOR CUSTOMER LOCK IS IN LOCKED POSITION WHEN KEY CAN BE REMOVED.

2. SLIDE 64042 PARCEL DOOR, LOCK STIFFENER ONTO THE PARCEL DOOR BOLTS, AS ORIENTED IN THE ILLUSTRATION.

3. INSTALL ARROW LOCK AS SHOWN USING FOUR (4) 86455 10-32 THIN LOCK NUTS. THESE NUTS SHOULD BE TIGHTENED TO ASSURE A SNUG FIT. OVERTIGHTENING MAY KEEP ARROW LOCK FROM OPERATING CORRECTLY.

4. INSTALL 64216 PARCEL DOOR ARROW LOCK COVER USING TWO (2) 84993 10-32x.312 UNF-2A 18-8 SS PASSIVATED MCGARD FASTENERS. NOTE: THESE FASTENERS REQUIRE A MCGARD SCREW DRIVER

**FOR U.S.P.S. INSTALLERS ONLY
SPECIAL NOTICE!**

U.S.P.S. INSTALLER MUST HAVE A MCGARD SCREW DRIVER (U.S.P.S. - MAIL EQUIPMENT SHOP PART NUMBER 11050) TO INSTALL AND SERVICE THE PARCEL LOCK COVER ON Auth-Florence 4C HORIZONTAL UNITS.

MCGARD SCREW DRIVERS ARE AVAILABLE BY FAXING AN "OFF CATALOG" eBUY REQUEST TO:

**U.S.P.S. MAIL EQUIPMENT SHOP
FAX NO. (202) 281-2643**

QUESTIONS? CALL THE U.S.P.S. MAIL EQUIPMENT SHOP AT (202) 281-2620



REQUIRED TOOLS

3/8" SOCKET WRENCH OR NUT DRIVER
USPS PROPRIETARY MCGARD SCREW DRIVER

PART #	DESCRIPTION
64210	PARCEL DOOR, LOCK STIFFENER
86455	10-32 THIN LOCK NUT
64216	PARCEL DOOR ARROW LOCK COVER
84993	10-32x.312 UNF-2A 18-8 SS PASSIVATED MCGARD
N/A	ARROW LOCK (PROVIDED BY U.S.P.S.)

PARCEL DOOR ARROW LOCK INSTALLATION (FOR U.S.P.S PERSONNEL ONLY)
(cont...)

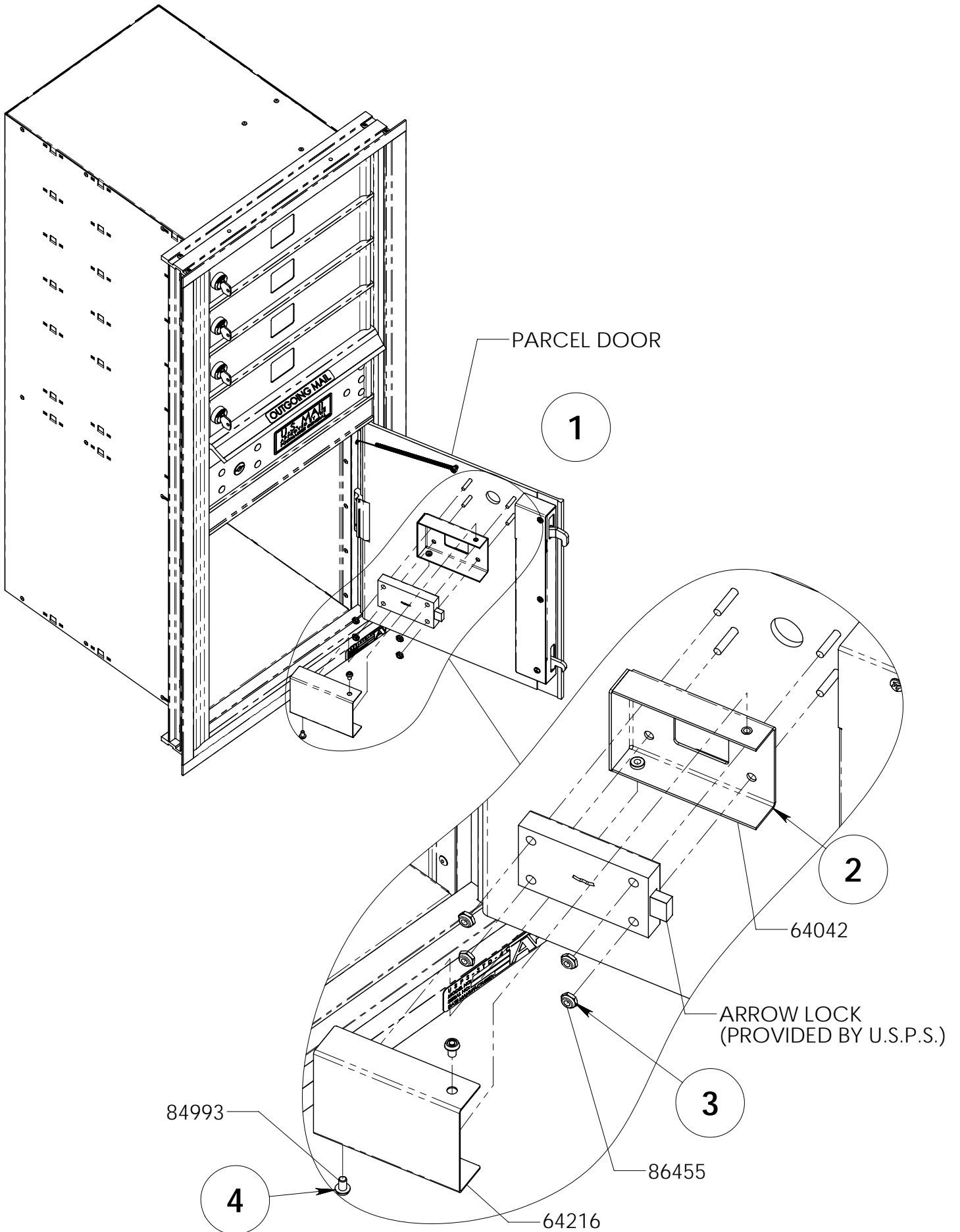

SUGGESTIONS FOR INDEPENDENT INSTALLATION WALL CONSTRUCTION

Auth-Florence 4C Horizontal Mailbox Systems (ALL TYPES)

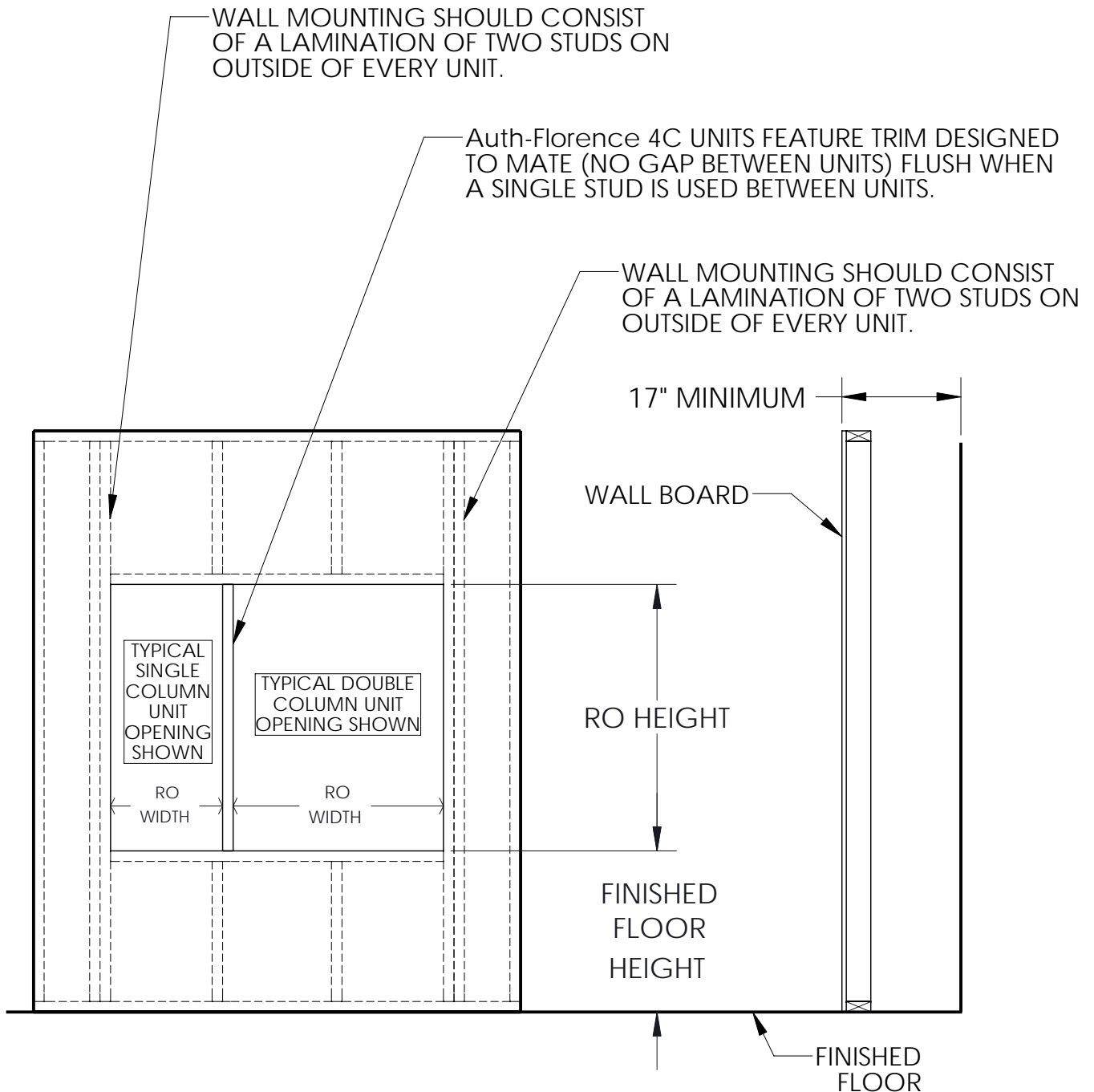

NOTES:

1. ALL WALL MOUNTING MEMBERS ARE MADE FROM WOOD 2"x4" (STUDS).
2. ALL WALL FRAME MEMBERS OTHER THAN THOSE DISCUSSED ON THIS PAGE ARE SHOWN FOR REFERENCE ONLY AND SHOULD COMPLY WITH LOCAL BUILDING CODES.
3. SQUARENESS AND QUALITY OF WALL MOUNT OPENING IS CRITICAL TO OBTAIN A SECURE AND PROPERLY FUNCTIONING Auth-Florence 4C UNIT.