

ELVOX®

Communicating in style

alpha
COMMUNICATIONS

42 Central Drive
Farmingdale, NY 11735-1202
TOLL-FREE 1-800-666-4800

Phone (631) 777-5500 Fax: (631) 777-5599
Email: info@alpha-comm.com
Internet: http://www.alpha-comm.com

POWER SUPPLY FOR SINGLE AND MULTI-RESIDENTIAL VIDEO DOOR ENTRY SYSTEMS WITH "SOUND SYSTEM" CALL

INSTALLATION AND OPERATION MANUAL

Art. 6680/C17

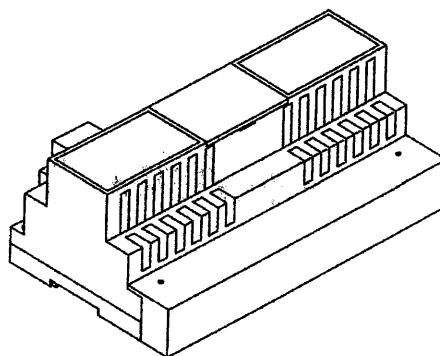

**Sound
system**

UL product is according to UL 6500

Descrizione dei simboli contenuti nel trasformatore.
doppio quadrato: l'alimentatore è Classe II;
triangolo con fulmine: pericolo di scossa, tensione pericolosa;
triangolo con punto esclamativo: pericolo, prestare attenzione.

Description of symbols shown in the transformer.
double square: it is a class II power supply
triangle with lightning: hazard of electric shock, dangerous voltage;
Triangle with exclamation mark: danger, pay attention.



CAUTION
RISK OF ELECTRIC SHOCK
DO NOT OPEN

GENERAL RULES FOR INSTALLATION

Wiring should be installed in separate lines from electrical and industrial cables. The use of coloured conductors will facilitate connections. For the camera entrance panel installation, please, note that:

- A) Camera operates from -5° + 50° C; to avoid overheating, protected it from sunlight with some form of shelter.
- B) Lens must be protected against direct light (sun, car headlights, etc.).
- C) Person to be framed by camera must be illuminated from the front. If lighting is insufficient use an additional external lamp powered directly by the mains.
- D) Before closing unit, clean protective glass and lens, repeat this operation from time to time.

Power supply Art. 6680/C17 must be placed in a dry place far from sources of dust and heat. To facilitate check-ups and adjustments, make sure that the place is easily accessible. Fix power supply to wall with proper support and fixing screws provided with the package or inserting it with proper DIN module. Before connecting it, ensure that conductors are not interrupted or short-circuited.

Installation should be made in lines separated from electric mains. To ensure user safety, all units run on low voltage and are separated from electric-mains by an high isolation transformer. It is advisable, in any case, to instal a thermal magnetic switch with an adequate capacity between the supplying mains and the unit. When repairing and/or servicing the power supply it will be sufficient to loosen the screws placed on the front side to remove the front panel, after having switched off the power.

IMPORTANT SAFETY INSTRUCTIONS

- 1- Read these instructions
- 2- Keep these instructions
- 3- Heed all warnings
- 4- Follow all instructions
- 5- Do not use this apparatus near water
- 6- Clean only with dry cloth
- 7- Do not block any ventilation openings. Install in accordance with the manufacturers instructions.
- 8- Do not install near any heat sources such as radiators, heat registers, stoves or other apparatus (including amplifiers) that produce heat.
- 9- Do not defeat the safety purpose of the polarized or grounding-type plug. A polarized plug has two blades with one wider than the other. A grounding type plug has two blades and a third grounding prong. The wide blade or the third prong are provided for your safety. If the provided plug does not fit into your outlet, consult an electrician for replacement of the obsolete outlet.
- 10- Protect the power cord from being walked on or pinched particularly at plugs, convenience receptacles, and the point where they exit from the apparatus.
- 11- Only use attachments/accessories specified by the manufacturer.
- 12- Refer all servicing to qualified service personnel. Servicing is required when the apparatus has been damaged in any way, such as power-supply cord or plug is damaged, liquid has been spilled or objects have fallen into the apparatus, the apparatus has been exposed to rain or moisture, does not operate normally, or has been dropped.
WARNING: To reduce the risk of fire or electric shock, do not expose this apparatus to rain or moisture.
CAUTION: These servicing instructions are for use by qualified service personnel only. To reduce the risk of electric shock do not perform any servicing other than that contained in the operating instructions unless you are qualified to do so.
- 13- Apparatus shall not be exposed to dripping or splashing and no objects with liquids, such a vases, shall be placed on the apparatus.













MINIMUM CONDUCTOR SECTION FOR STANDARD VIDEO-DOOR ENTRY SYSTEM AND TWO-CHANNEL VERSION WITH COAXIAL CABLE (in mm²)

Section type	Terminals	Ø fino a 50 m.	Ø fino a 100 m.	Ø fino a 200 m.
a	0, 3, 12, 15, -, +, AS, S1 C1, C2, C3, P1, P2, +T lock, calls	1 mm ²	1,5 mm ²	2,5 mm ²
b	Other	0,75 mm ²	1 mm ²	1,5 mm ²
Video		75 Ohm coaxial cable (type RG59) or RG11 double insulation		

Conversion table of sections-diameters and relative resistances for 100 m. standard conductors.

Section mm ²	0,12	0,25	0,35	0,50	0,75	1,00	1,50	2,50	4,00	6,00
Diameter mm.	0,40	0,58	0,68	0,80	1,00	1,15	1,40	1,80	2,30	2,80
AWG	26	23	22	20	18	16	14	12	10	
Decimal diameter	4/10	6/10		8/10	10/10	12/10	14/10	18/10		
Resistance Ω 100m.	14,00	6,60	4,80	3,50	2,20	1,70	1,14	0,69	0,39	0,28

SYMBOLS

	A.C. bell		Bulb		Loudspeaker		A.C. supply from mains
	A.C. buzzer		Push-button		Amplified microphone		Ground
	Electric lock		Switch		Receiver		Coaxial cable block

OPERATION

The video door entry installation consists of one camera entrance panel with speech unit, one power supply and one or more monitors. The system can operate with monitors and B/W or colour cameras and with or without conversation privacy. The power supply is not equipped with intercommunicating section; nevertheless it is possible to carry out a monitor and/or intercommunicating interphones network using switching module type 935A in conjunction with the basic power supply.

When an entrance panel push-button is pressed, the chime rings in the corresponding apartment. Almost immediately the image of the caller appears on the monitor. The coverage area is illuminated by built-in infrared leds when using B/W camera, or by a built-in white light when using a colour camera.

If desired, the user may simply raise the interphone, communicate with the caller and, if appropriate, activate the door-opener. In this case, door-opening time may be varied from 1 to 30 seconds using the potentiometer P3.

The system turns itself off automatically after a preset time, adjustable from 30 to 90 seconds using potentiometer P1 inside the power supply. If the caller presses another user's push-button, the previously called monitor is automatically deactivated without waiting for the end of the preset time. When testing the installed system, use trimmer P2 to adjust the optimal volume of the speech unit. For simultaneous activation of two or ore monitors one extra power supply type 5582/C17 must be installed for each additional monitor or type 6583 for more monitors. A blocking circuit cuts off power to monitors if the line is overloaded or short-circuited. The power supply is also equipped with a specific device to eliminate any buzzing on the voice circuit caused by the use of wires that are too long and/or too thin only in installations with "SOUND SYSTEM" call. Push-buttons with name-tags are illuminated through output 0-15 on power supply. Up to a maximum number of three 24V 3W bulbs can be connected. An additional transformer, type M832 or 832/030 is required for entrance panels with more bulbs.

Technical specifications of power supply type 6680/C17 - (6680/C17/V03)

Type 6680/C17 is the basic power supply for all video door entry systems with SOUND SYSTEM call and is equipped with an electronic double tone generator, which replaces conventional alternative calling with a buzzer or bell. The sound is emitted with two different tones (present on terminals C1-C2) thereby allowing the user to immediately identify the source of the call (main entrance, gate, garage, etc.). This feature provides economic and practical advantages since the use of several conventional sound emitting systems is no longer required; the signal is emitted from a single loudspeaker in the interphone. In some cases, savings can be made on the cable routing work requirements for additional bell systems. Manufactured in technopolimer class V-0 housing; preset for mounting on cases with 12-Module DIN support or with expanding plugs with screws.

- 117V A.C. 60Hz supply (other voltages on request) with polarized plug
- 60VA maximum absorbed power.
- Dissipated power: 15W
- 18V D.C. 0.8A monitor supply (90 sec. ON, min. 90 sec. OFF)
- 13V D.C. 0.3A camera supply (90 sec. ON, min. 90 sec. OFF)
- 15V rectified voltage 0.25A continuous duty for push- button illumination (3x24V 3W max)
- Door lock output: 15V A.C. 1A intermittent cycle, (30 sec. ON, min. 150 sec. OFF)
- Amplified electric door-opener system.
- Timer and automatic disconnection device of monitor previously activated.
- Interchangeable cards for quick maintenance.
- Removable terminal blocks.

POWER SUPPLY OPERATING MODES

- Selector set A-B:
- "A" Position: operating with sound system call, to be used in case of summing noises (caused by power supply, door lock or lamps) detected on the interphone line.
- "B" Position: normal operation with Sound System call, switching module in "A" position only in case of summing noises on the audio line.
- "B" Position: operating with 15V A.C. call only. In this case power supply 6680/C17 completely replaces power supply type 6580.

PROTECTION OF POWER SUPPLY:

- Primary coil of transformer by PTC SIEMENS C830
- 1st. secondary coil for internal electronic supply by F 3, 15A 250V (F1) fuse.
- 2nd. secondary coil for lock supply by PTC SIEMENS C945
- Electronic protection against short-circuits and overloadings on monitor cable riser.
- Electronic protection against overloadings to outdoor unit.

ADJUSTMENTS

P1 - Activation time adjustment for monitor and camera.

P2 - Volume adjustment of speech unit.

P3 - Activation time adjustment for electric lock.

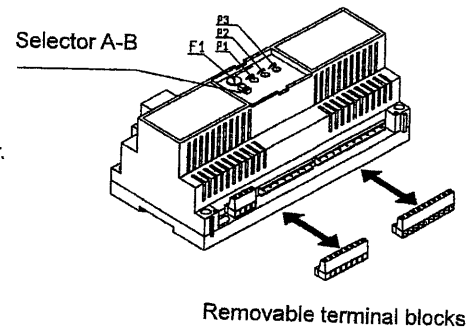

N.B.: The electric door lock must operate by way of an intermittent cycle so that one operating period corresponds to 5 rest periods, thereby preventing the protection device from overheating (one period corresponds to the door lock activation time).

Dimensions type 6680/C17 - 6680/C17/V03: 208x135x72 - Weight: 1.4 Kgs.



TERMINALS FOR MONITOR type 6300, 6301, 6303, 6500, 6501

- 1: Interphone receiver
- 2: Interphone microphone
- 3: Common audio line

- 4: Button for auxiliary services 
- 5: Power supply negative
- 6: Power supply positive (minimum input voltage 15V DC)
- 7: Not connected.
- 8: Call from entrance panel
- 9: Lock push-button 
- 10: 12V DC output for video distributor
- 11: Outdoor call

- 12: System auto-activation push-button 
- 13: Green LED supply voltage
- V1: For systems with coaxial cable, input for connection of the 75 Ohm video cable. For systems without coaxial cable, input for connection of the V1 signal.
- V2: For systems with coaxial cable, output for connection of the 75 Ohm video cable or connection of the load resistance of 75 Ohm in the last monitor of the cable riser.
- V3: For systems without coaxial cable, input for connection of the V2 signal.
- M: Ground for terminals V1, V2, V3.
N.B. The monitors type 6300, 6500 have a microswitch on the back for setting the connection "coaxial cable/without coaxial cable" and one for the setting "conersation privacy/without conersation privacy" (type 6300,6303,6500).

TERMINALS FOR MONITOR type 6000, 6003

- V1: Input for connection of 75 Ohm video cable in systems with coax cable; input for connection of video signal V1 in systems without coax cable.
- V2: Output for connection of 75 Ohm video cable or 75 Ohm resistor in last monitor in systems with coax cable.
- V3: Input for connection of video signal V2 in systems without coax cable.
N.B. Terminal V3 must be shorted to terminal M in systems with coax cable.
- M: Earth for terminals V1, V2 and V3.
- +A: Not used
- +: Power supply (positive), minimum input voltage 15 V d.c.
- : Power supply (negative), minimum input voltage 15 V d.c.
- +D: +12 V d.c. output for video distributor
- CH: Monitor activation call
- CN2: Monitor interface connector

INTERPHONE 6200

- CN1: Monitor interface connector
- 7: Lock release push-button
- AU: Monitor auto-activation control
- 1: Interphone receiver
- 2: Interphone microinterphone
- 3: Phonic common
- 6E: entrance panel call
- 6: Intercommunicating call
- 6P: Apartment outdoor call
- 6S: Ringtone activation output

POWER SUPPLY TERMINALS

**SUGGESTED CONDUCTOR COLOUR
(Ref. Cable type 61/001)**

1: Interphone receiver	SKY BLUE] CONNECTIONS TO MONITORS + INTERPHONES
2: Interphone microphone	WHITE	
3: Common interphone line	PINK	
-: Negative terminal of monitor supply voltage	BLACK SECT. 1mm	
+: Positive terminal of 18V D.C. 0.8A monitor supply	RED SECT. 1mm	
S: Control of lock relay	BROWN	
M: Block of coaxial cable shield] CONNECTION TO CAMERA ENTRANCE PANEL
V1-V2: Block of video signal (on coax cable)	COAXIAL CABLE	
6: Common interphone line for speech unit	PINK	
7: Speech unit microphone	WHITE	
8: Speech unit loudspeaker	SKY BLUE	
+T: 13V D.C. 0.3A camera supply voltage	OSERIES	
-: Negative line for camera supply voltage	BLACK SECT. 1mm	
AM: Short-circuited to negative line, blocks monitor activation		
0: 0V (with reference to terminal 16)	BROWN	
15: 15V rectified voltage (selector in "A" position).or 250mA alternated (selector in "B" position on continuous operation)	RED SECT. 1mm	
S1: Wiring to electric lock	BLUE SECT. 1mm	
C1: Speech unit electronic call	GREEN	
C2: Electronic call outside apartment door	WHITE/GREEN	

"SOUND SYSTEM" SINGLE AND MULTIPLE RESIDENCE VIDEO DOOR ENTRY SYSTEM WITH POWER SUPPLY TYPE 6680/C17 AND WITHOUT CONVERSATION PRIVACY

MONITOR CABLE RISER

B/W MONITOR
type 6000 +
type 6200 +
type 6145

COLOUR MONITOR
type 6003 +
type 6200 +
type 6145

B/W MONITOR
type 6300 **
type 6301
type 6500 **
type 6501

COLOUR MONITOR
type 6303 **

* Connect 75 Ohm resistor (supplied) to the last monitor, between terminals V0 and V1.

**
N.B.
The monitors have a microswitch on the back, set it to "without conversation privacy".

N.B.
The monitors have a microswitch on the back for connection "with coaxial/without coaxial"; set the microswitch to "coaxial".

CABLE
type 61/001
type 61/003

N.B.
In the event of buzzing on the audio line, move the switching module "A-B" located under the cover to position "A".

- A- Video entrance panel
GALILEO SECURITY, GALILEO,
PATAVIUM and letter box 2550/301-302 series
- B- Additional door lock button
- C- 12V~ electric lock
- D- Camera with speech unit
type 559, 559A, 559B, 559G, 558, 570,
570G, 571, 559C and 570C
- L1- entrance panel illumination bulb
(3x24V 3W max.)
10x24V 3W with type M832
16X24V 3W with type 832/030

CAVO
type 61/001
type 61/003

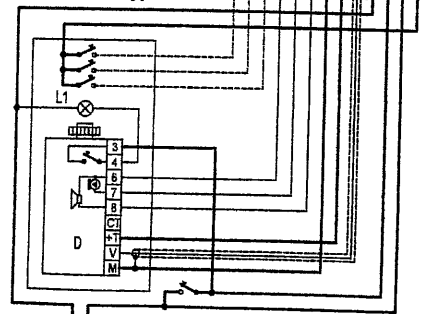

DIAGRAM N° vc4306

**"SOUND SYSTEM" SINGLE AND MULTIPLE RESIDENCE VIDEO DOOR ENTRY SYSTEM WITH POWER SUPPLY
TYPE 6680/C17 AND CONVERSATION PRIVACY**

MONITOR CABLE RISER

B/W MONITOR
type 6000 +
type 6200 +
type 6145 +
type 6155

COLOUR MONITOR
type 6003 +
type 6200 +
type 6145 +
type 6155

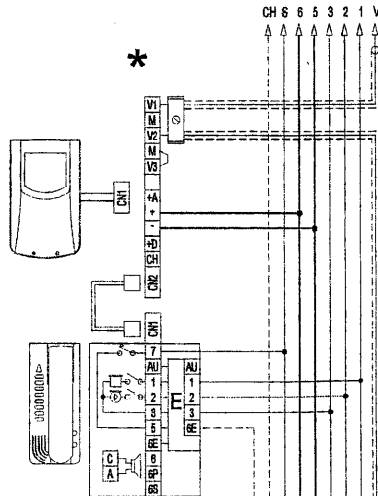

CABLE
type 61/001
type 61/003

B/W MONITOR
type 6300 **
type 6500 **

COLOUR MONITOR
type 6303 **

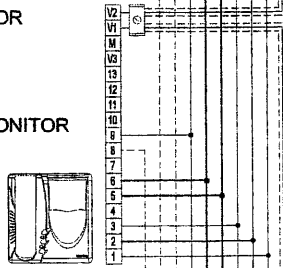

* Connect 75 Ohm resistor (supplied) to the last monitor, between terminals V2-M.

** **N.B.**
The monitors have a microswitch on the back, set it to "without conversation privacy".

N.B.
The monitors have a microswitch on the back for connection "with coaxial/without coaxial"; set the microswitch to "coaxial".

N.B.
In the event of buzzing on the audio line, move the switching module "A-B" located under the cover to position "A".

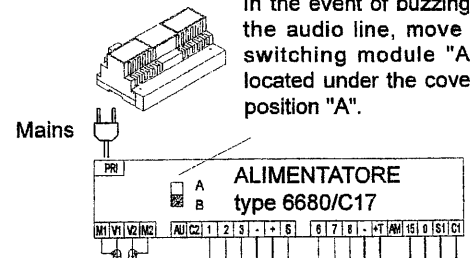

- A- Video entrance panel
GALILEO SECURITY, GALILEO,
PATAVIUM and letter box 2550/301-302 series
- B- Additional door lock button
- C- 12V~ electric lock
- D- Camera with speech unit
type 559, 559A, 559B, 559G, 558, 570,
570G, 571, 559C and 570C
- L1- entrance panel illumination bulb
(3x24V 3W max.)
10x24V 3W with type M832
16x24V 3W with type 832/030

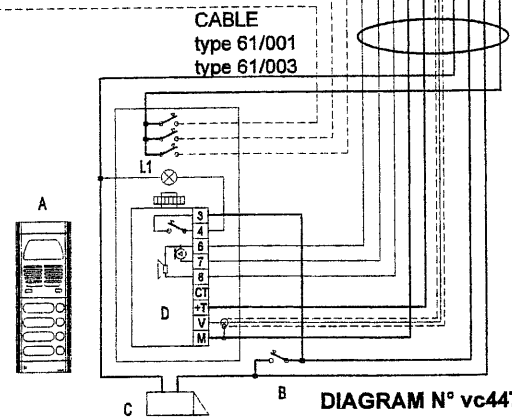

DIAGRAM N° vc4476

INTERCOMMUNICATING VIDEO DOOR ENTRY SYSTEM WITH SWITCHING MODULE TYPE 935A

SYSTEM DESCRIPTION

The diagram shows the connection of one monitor and 7 interphones (all intercommunicating with each other and with the outdoor unit). More or fewer monitors and interphones may be connected, but the total number must not exceed 8 units corresponding to the number of push-buttons. When the total number of units is less than 8, only the terminal blocks of concerned intercommunicating units must be linked, excluding the call conductors of the other numbers.

Example: In the case of 3 intercom units (one monitor and 2 interphones as illustrated in the diagram above), connect terminal boards 1 to 11 on the interphones.

The monitors and interphones are fitted with loudspeakers capable of receiving separate electronic call signals both from the outdoor unit and from other intercommunication devices. The calls from entrance panel (C1) and from the apartment door button (C2) are generated by the power supply Art. 6680/C17, while the intercommunication call signal (C3) is supplied by the switching module Art. 935A.

OPERATING PRINCIPLE

The video door entry system consists of one camera entrance panel, one power supply and one or more monitors. When a push-button of entrance panel is pressed, the ringtone rings in the corresponding apartment. Almost immediately the image of the caller appears on the monitor. A number of built-in infrared LEDs lights the coverage area when using a B/W camera, or LED diodes with white light when using a colour camera. If desired, the user may simply raise the interphone, communicate with the caller and, if appropriate, activate the door lock release. In this case the door-opening time may be varied from 1 to 30 seconds using potentiometer P3. The system turns itself off automatically after a preset time, adjustable from 30 to 90 seconds using potentiometer P1 inside the power supply.

EXTERNAL COMMUNICATIONS:

When the external call signal is heard, pick up the interphone to directly communicate outside. 60 seconds after the start of the conversation an electronic device within the switching module type 935A switches communication to internal only, and so to continue the conversation it is necessary to call again from the entrance panel.

INTERNAL COMMUNICATIONS:

Lift interphone and press push-button corresponding to desired interphone. Outdoor unit is automatically excluded.

INTERCOMMUNICATING VIDEO DOOR ENTRY SYSTEM FOR SINGLE RESIDENCE WITH POWER SUPPLY 6680/C17 AND SWITCHING MODULE TYPE 935A

* Connect 75 Ohm resistor (supplied) to the last monitor, between terminals V2-M.

INTERPHONE SETTING TYPE 6200 + 6152 FOR MONITOR

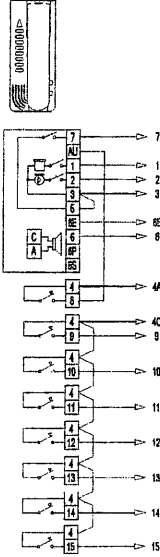

INTERPHONE SETTING TYPE 6200 + 6152 SECONDARY

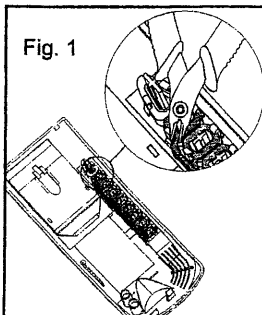
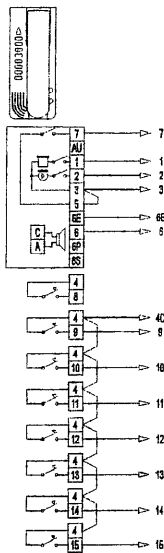

Before connecting the system, fit the buttons type 6152 in their seat in the interphone. Connect the jumpers as shown in the diagram. Then distribute the keys in the interphone housing, removing the plastic that holds them as shown in figure 1.

B/W MONITOR

type 6000 +
type 6200 +
type 6145 +
type 6152

COLOUR MONITOR

type 6003 +
type 6200 +
type 6145 +
type 6152

A- Video entrance panel
GALILEO SECURITY, GALILEO,
PATAVIUM and letter box 2550/301-302
series

B- Additional door lock button

C- 12V~ electric lock

D- Camera with speech unit
type 559, 559A, 559B, 559G, 558, 570,
570G, 571, 559C and 570C

L1- entrance panel illumination bulb
(3x24V 3W max.)

10x24V 3W with type M832

16X24V 3W with type 832/030

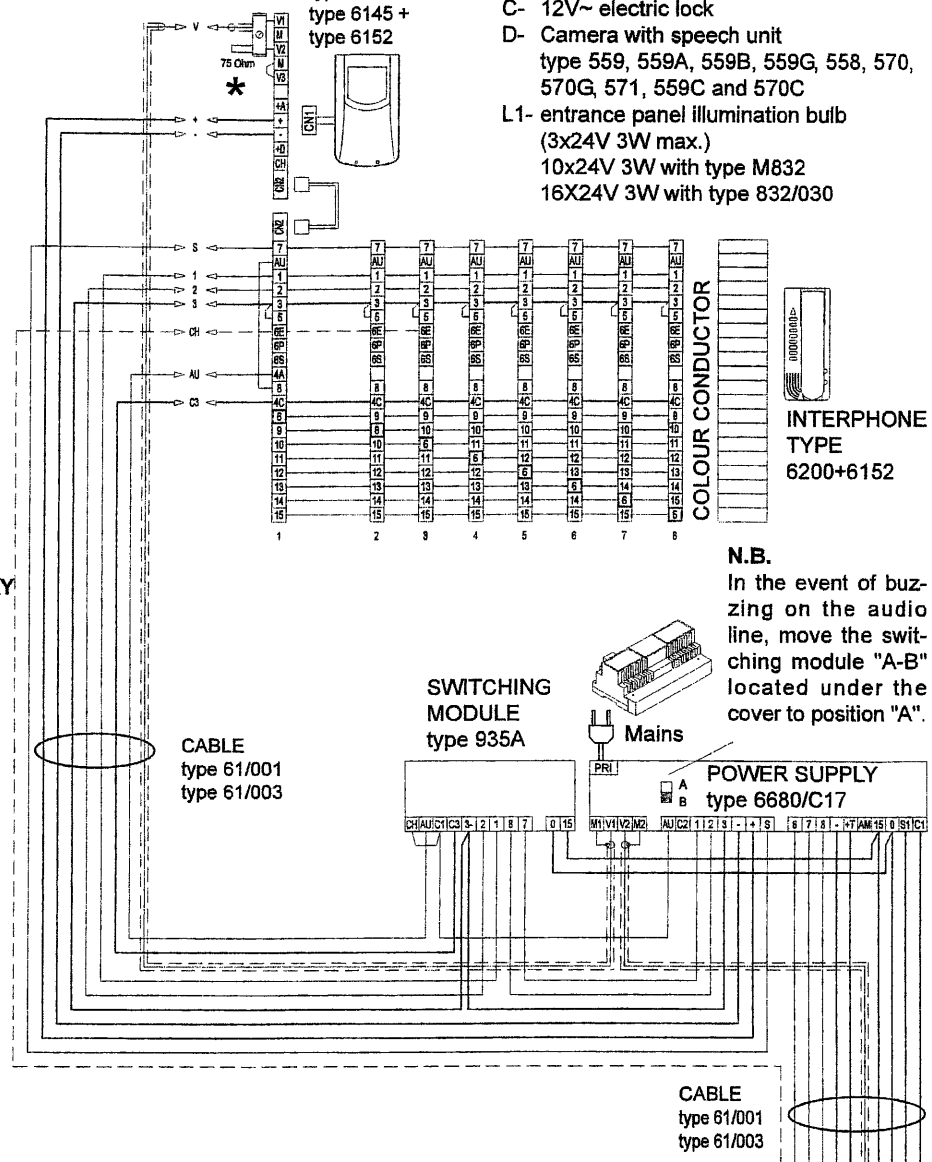

N.B.

In the event of buzzing on the audio line, move the switching module "A-B" located under the cover to position "A".

N.B.

The monitors have a microswitch on the back for connection "with coaxial/without coaxial"; set the microswitch to "coaxial".

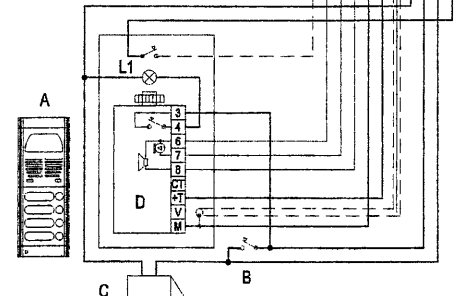

DIAGRAM N° vc3242

EXAMPLE OF INTERCOMMUNICATING MONITORS AND INTERPHONES FOR SINGLE RESIDENCE VIDEO DOOR ENTRY SYSTEM WITH SWITCHING MODULE TYPE 935A

Fig. 1
Two monitors and seven intercommunicating interphones.

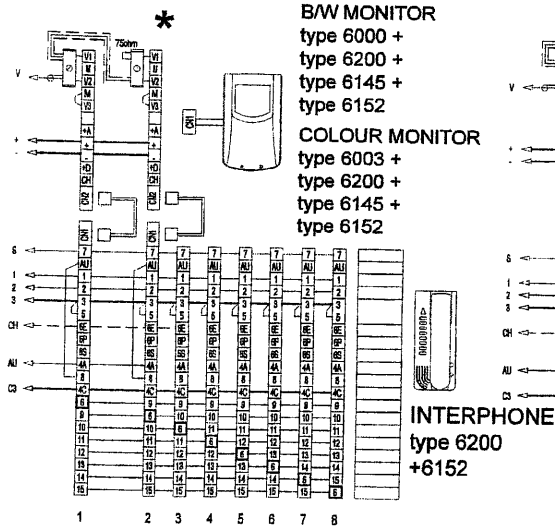

Fig. 2
Three monitors and five intercommunicating interphones.

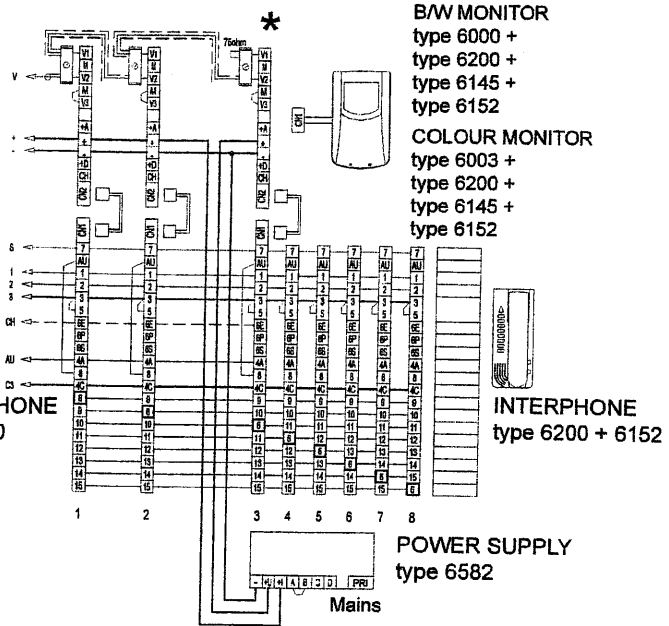

Fig. 3
Four monitors and four intercommunicating interphones.

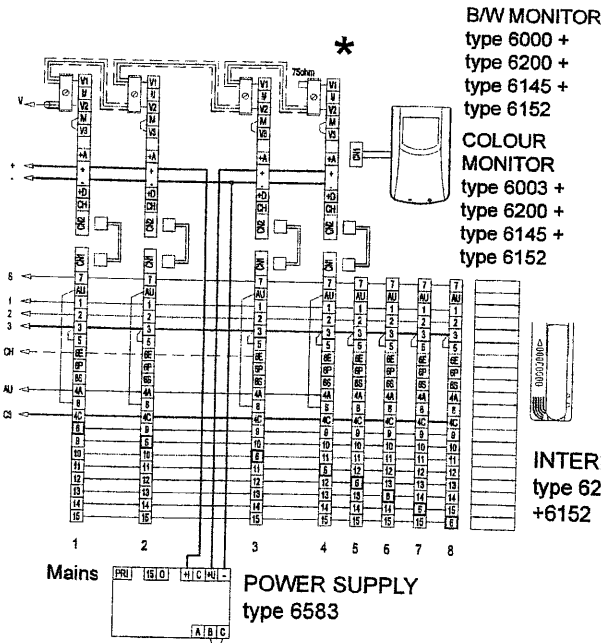
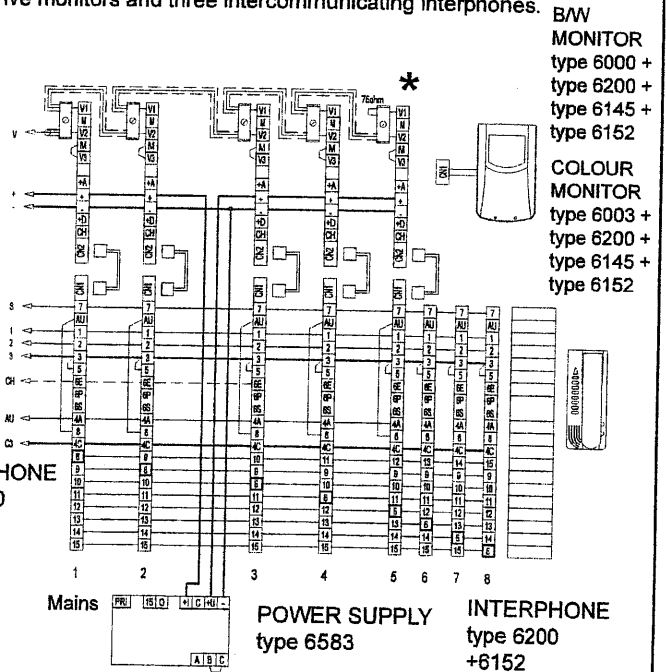

Fig. 4
Five monitors and three intercommunicating interphones.



★ Connect 75 Ohm resistor (supplied) to the last monitor, between terminals V2-M.

Notes:

These wiring diagrams refer to a single residence installation. Call line (monitor terminal no. 6E) allows simultaneous activation of all appliances. On installations for several intercommunicating apartments, terminal no. 6E of each monitor will be connected to entrance panel corresponding push-button.

For a simultaneous activation of several monitors use an additional power supply type 5582/C17 for each monitor starting from the 3th one or power supply type 6583 for two (or max three monitors) operating simultaneously according to shown wiring diagrams.

If all interphones and monitors should receive a call from the entrance panel (terminal no. 6E-8), it is necessary to install one or more call repeaters type 934 (see version).

STANDARD VIDEO DOOR ENTRY SYSTEM WIRING DIAGRAM VERSIONS WITH COAX CABLE

VERSION 1

Wiring diagram with simultaneous activation of two or more monitors by power supply type 5582/C17

The power supply type 6680/C17 can simultaneously power two monitors type 6000, 6003, 6300, 6301, 6303 or one monitor type 6500, 6501 by connecting them as shown in the diagram.

With a larger number of monitors switched on simultaneously, it is necessary to use the additional power supply type 5582/C17: connect a maximum of two monitors type 6000, 6003, 6300, 6301, 6303, or one monitor type 6500, 6501, or use the desk-top bases with

built-in power supply. For simultaneous switch-on of more than one monitor with the same call, use type 934 to regenerate the call signal.

Use type 934 after the 3rd monitor and for a further 4 monitors.

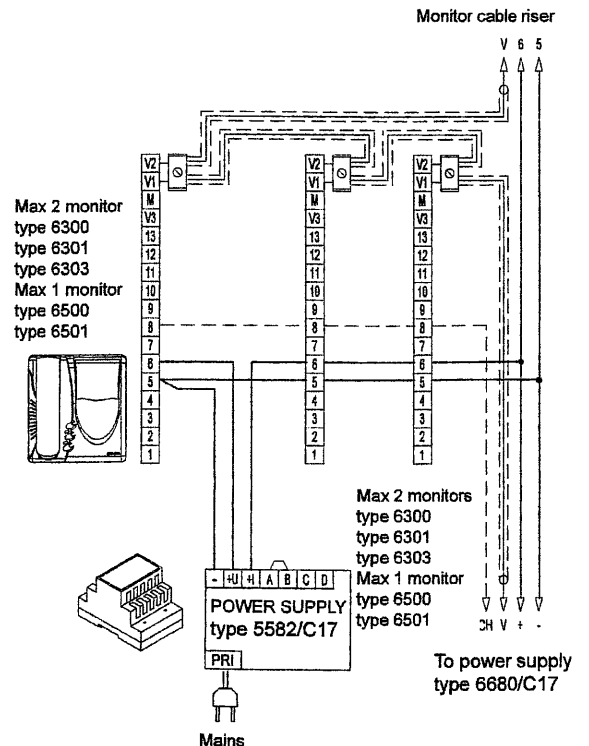
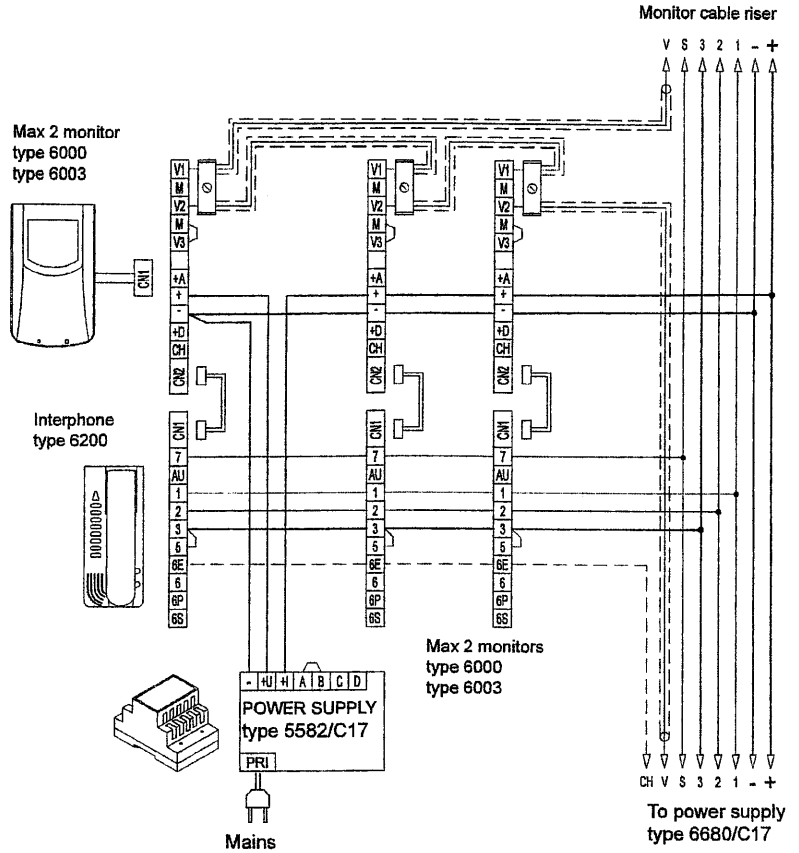

STANDARD VIDEO DOOR ENTRY SYSTEM WIRING DIAGRAM VERSIONS WITH COAX CABLE

VERSION 2

Wiring diagram with simultaneous switch-on of two or more monitors with power supply type 6583, with call repeater type 934.

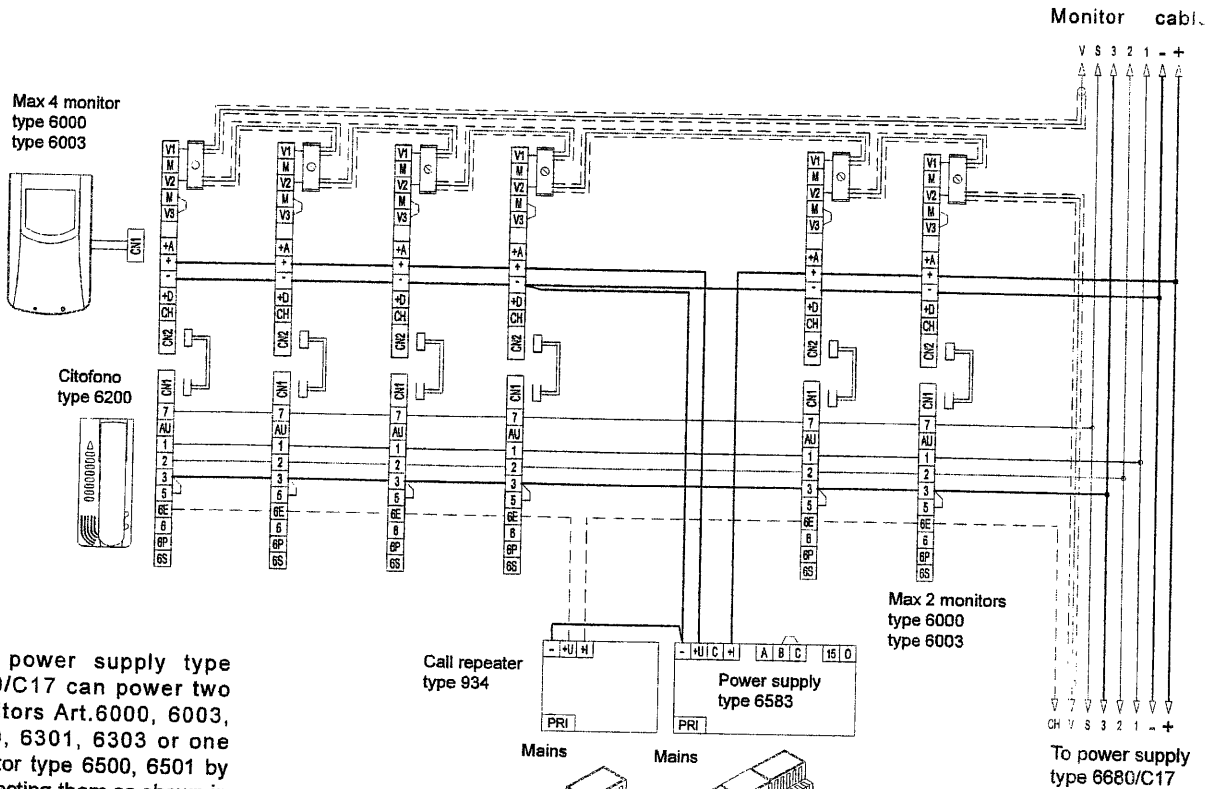

The power supply type 6680/C17 can power two monitors Art.6000, 6003, 6300, 6301, 6303 or one monitor type 6500, 6501 by connecting them as shown in the standard diagram.

For simultaneous switch-on of more than one monitor, it is necessary to use the additional power supply type 6583: connect a maximum of four monitors type 6000, 6003, 6300, 6301, 6303, or two monitors type 6500, 6501, or use the desk-top bases with built-in power supply.

Max 4 monitors type 6300 type 6301 type 6303
Max 2 monitor type 6500 type 6501

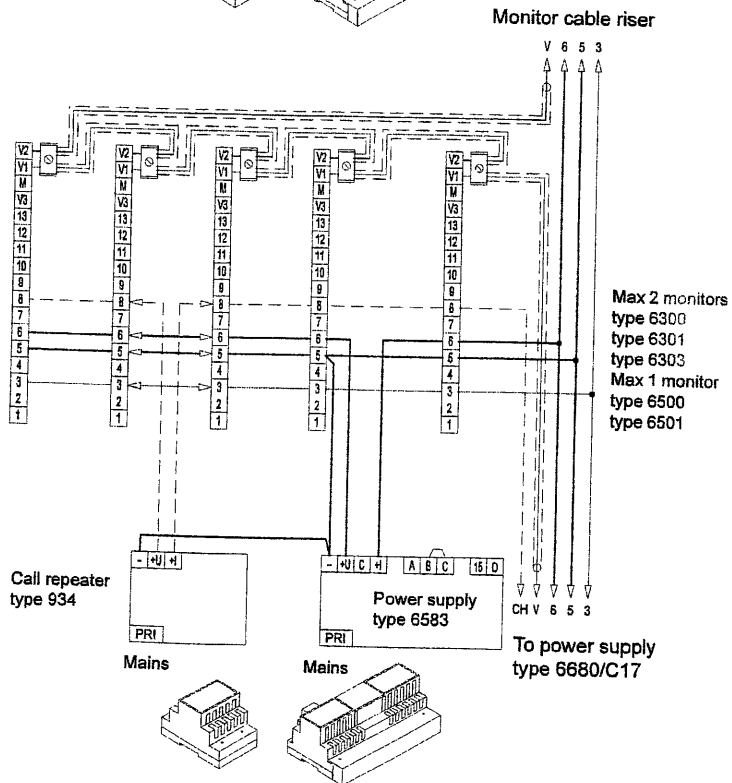
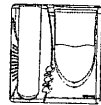

STANDARD VIDEO DOOR ENTRY SYSTEM WIRING DIAGRAM VERSIONS WITH COAX CABLE

VERSION 3

Connection of power supply type 6583 on installations with considerable voltage drop on power line "+ -".

Stand-by line power supply type 6583 may be connected as shown in the diagram in case of long supply lines where power voltage on the line wiring to the monitors (+ -) is less than 15V D.C. between terminals 5-6. The unit can supply 18V D.C. 2A with intermittent operation.

If a line with excessive voltage drops powers a single monitor, you can use the power supply type 5582/C17.

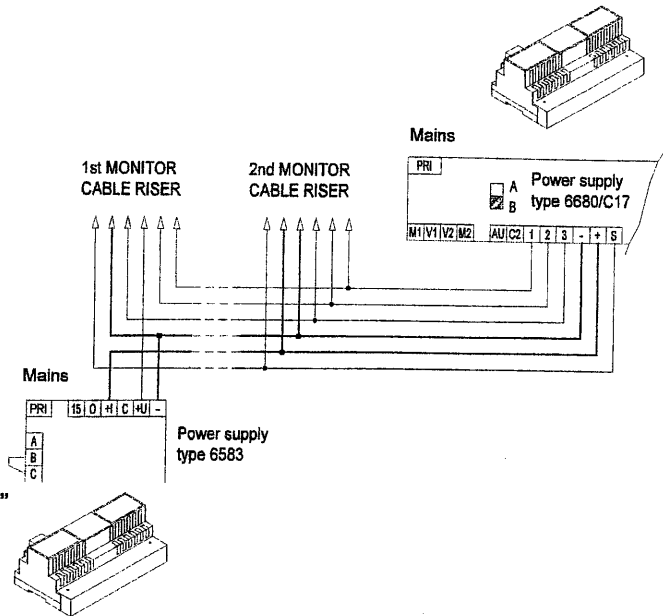

N.B. Set jumper in "B-C"

VERSION 4

Connection of call repeater type 2/841.

The loudspeaker module type 2/841 repeats the monitor sound leaving the tone unaltered.

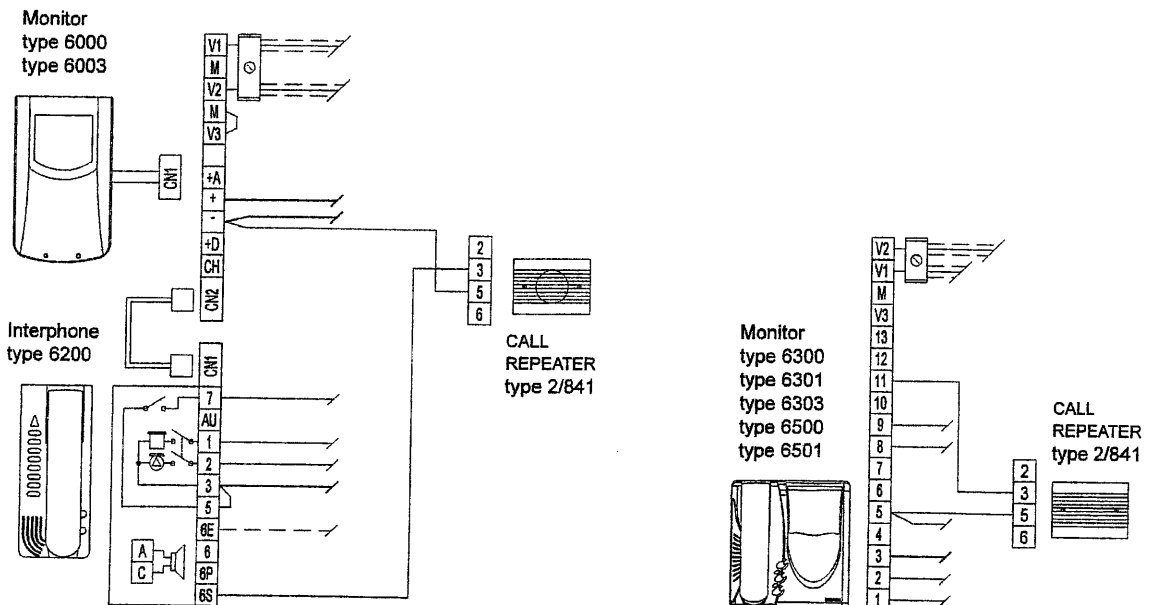

STANDARD VIDEO DOOR ENTRY SYSTEM WIRING DIAGRAM VERSIONS WITH COAX CABLE

VERSION 5

Wiring diagram of additional electronic ringtone type 860A.

N.B. Electronic ringtone type 860A features a two or three-notes ringtone which is selected by connection to the corresponding terminal (7 or 8). The ringtone is powered by the mains voltage.

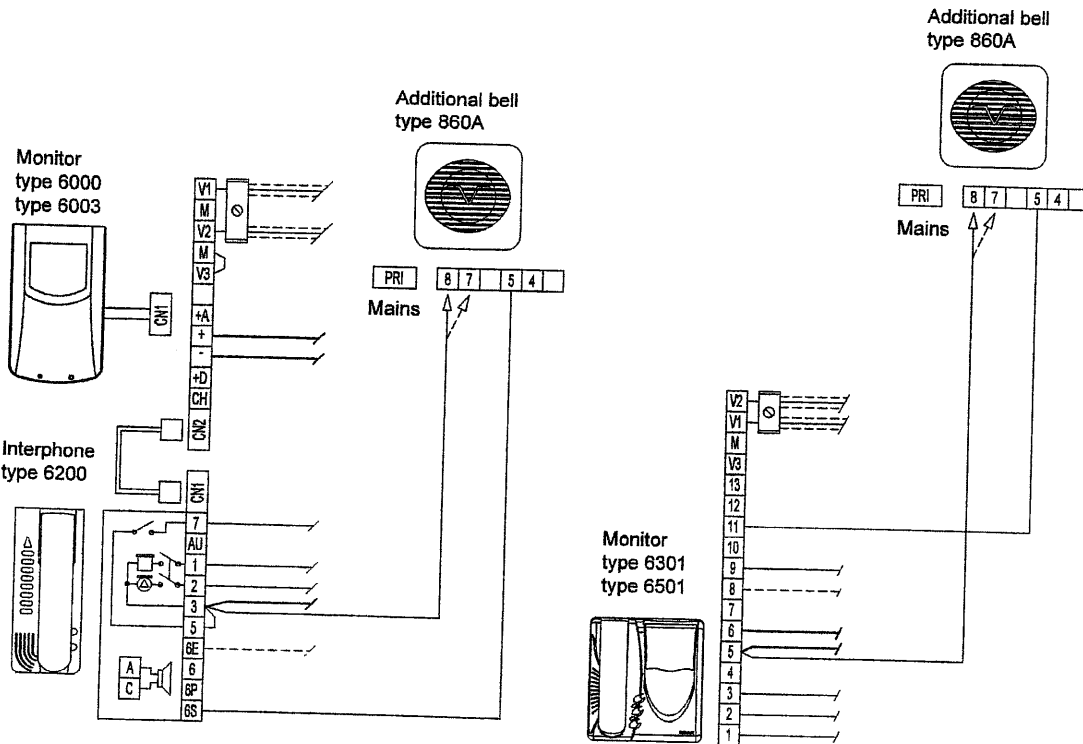

A- Outdoor call push-button
B- Diode 1N4004, type R027

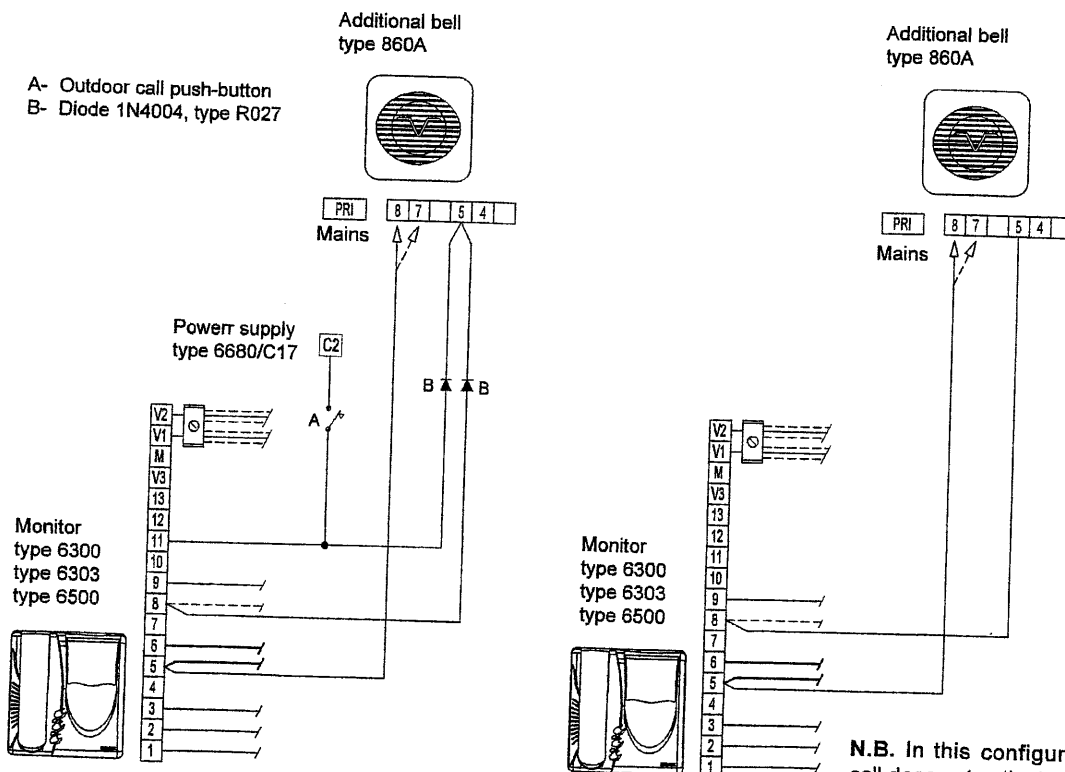

N.B. In this configuration, the outdoor call does not activate the additional bell.

STANDARD VIDEO DOOR ENTRY SYSTEM WIRING DIAGRAM VERSIONS WITH COAX CABLE

VERSION 6

Wiring diagram for additional mechanical doorbells.

The diagram shows the connection of additional doorbells operating at 12 V AC or at the mains voltage using relay type 170/101, by connecting it as shown in the diagram.

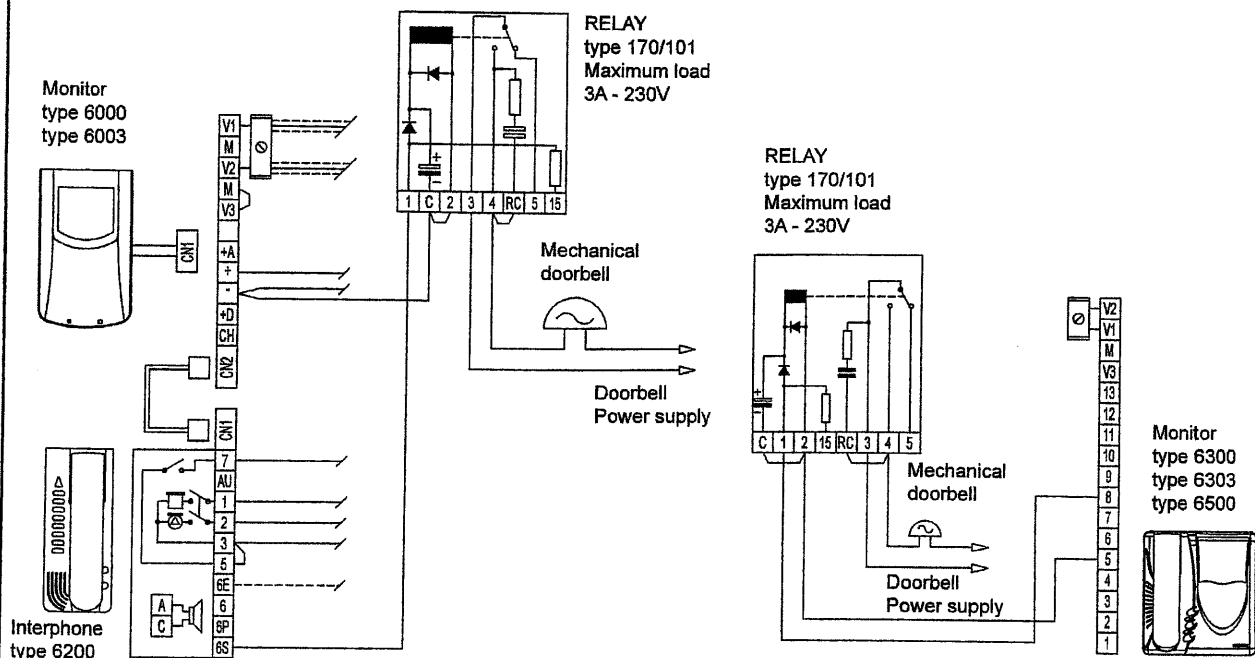

N.B. In this configuration, the outdoor call does not activate the relay

- A- Outdoor call push-button
- B- Diode 1N4004 and type R027

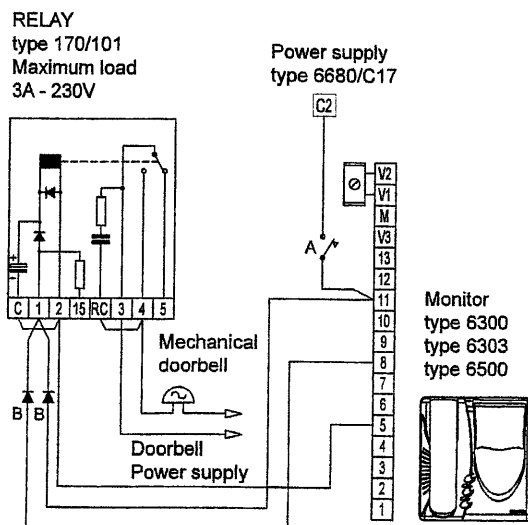
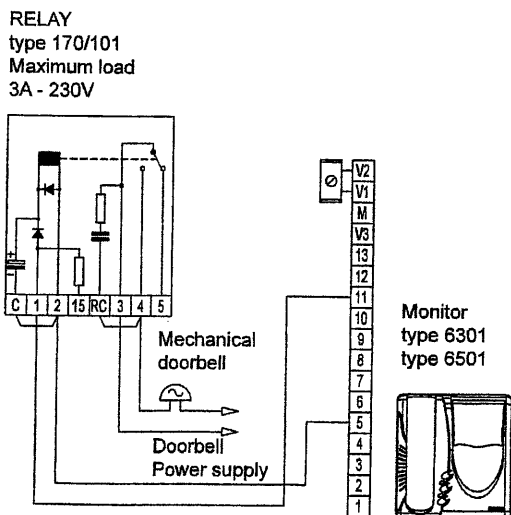

STANDARD VIDEO DOOR ENTRY SYSTEM WIRING DIAGRAM VERSIONS WITH COAX CABLE

VERSION 7

Wiring diagram for door call button.

When the outdoor call push-button is pressed, the monitor sounds with a different tone from the tone generated by a call from the entrance panel.
The monitor remains OFF.

A- Outdoor call push-button

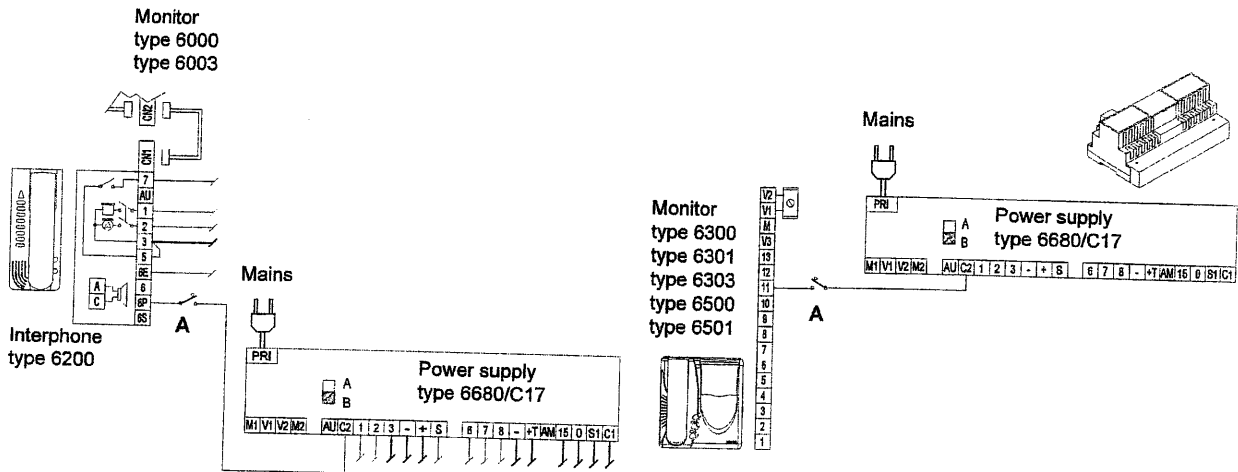

If type 6150 is installed inside interphone type 6200, the door call cannot be used.

VERSION 8

Wiring diagram for switching on the stair light or other services powered by AC mains by means of relay type 170/001.

To switch on the stair light in this case, press push-button number 1. You can connect any one of the eight additional buttons of type 6152.

The capacity of the contacts of the monitor push-button is 24 V DC/AC 0.5A max.

To activate the auxiliary service press the push-button with the symbol . The capacity of the contacts of the interphone push-button is 24 V D.C./AC 0.5 A max.

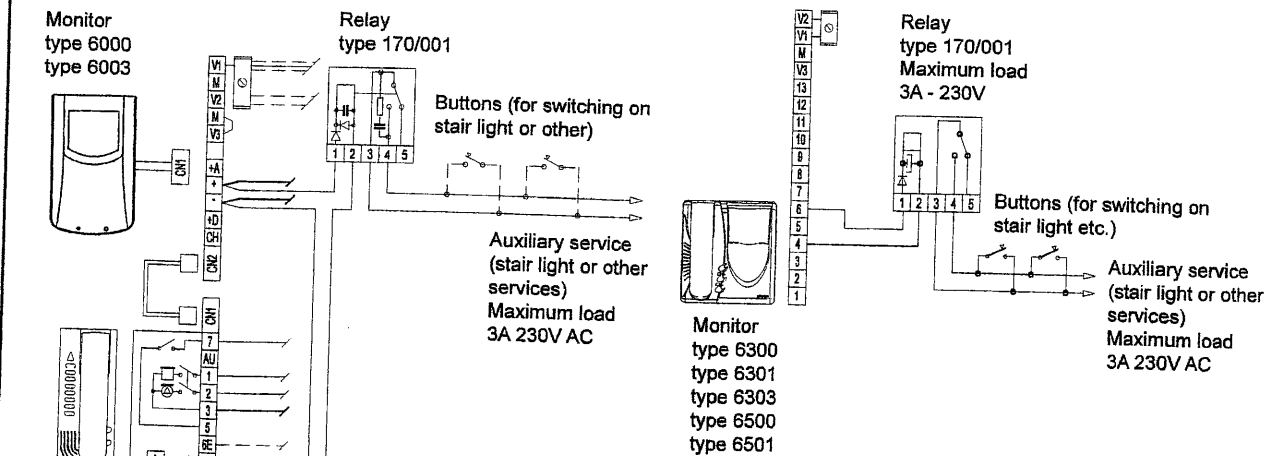

STANDARD VIDEO DOOR ENTRY SYSTEM WIRING DIAGRAM VERSIONS WITH COAX CABLE

VERSION 9

Wiring diagram for auto-activation of monitor

To activate the video system from the monitor, press push-button number 1, because this push-button has been used in the diagram. You can, however, connect any one of the eight additional buttons type 6152. The capacity of the contacts of the monitor push-button is 24 V DC/AC 0.5A max.

It is possible to activate the video system from the monitor, using the push-button with the symbol "□" on interphones type 6200, by connecting it as shown in the diagram.

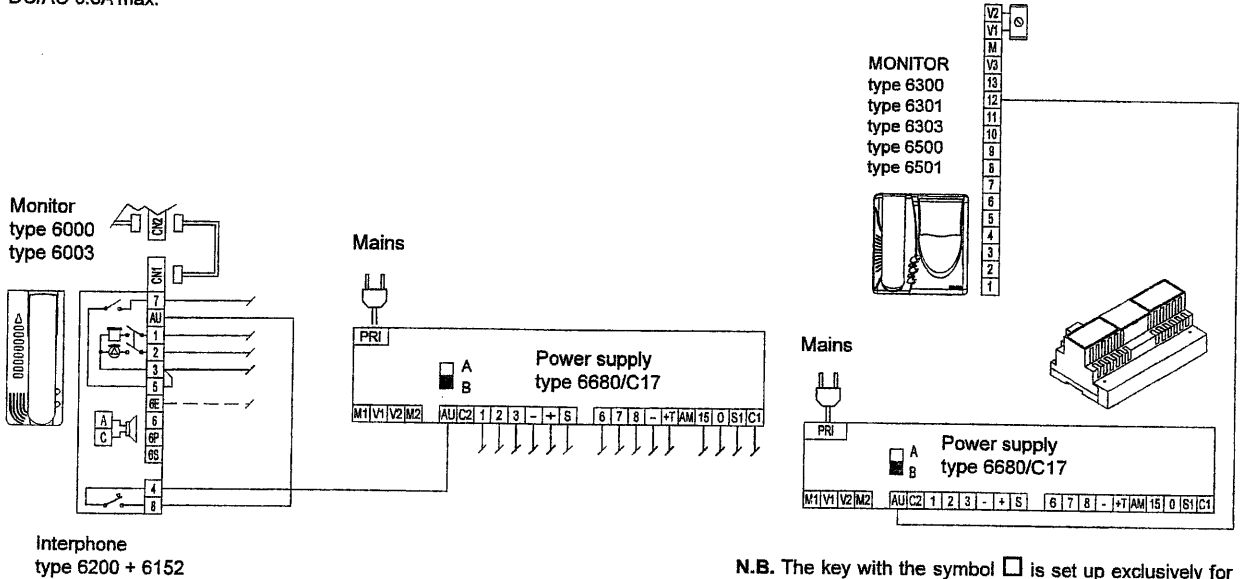

N.B. The key with the symbol □ is set up exclusively for auto-activation of the system and cannot be used for other purposes.

VERSION 10

Wiring diagram of video door entry system with "SOUND SYSTEM" call and ringtone type 6150.

The electronic ding-dong ringtone card type 6150 can be installed in interphone type 6200 to convert the sound generated by the power supply type 6680/C17.

N.B. The loudspeaker must be disconnected from the interphone's motherboard and connected to connector "A-A" on the interphone.

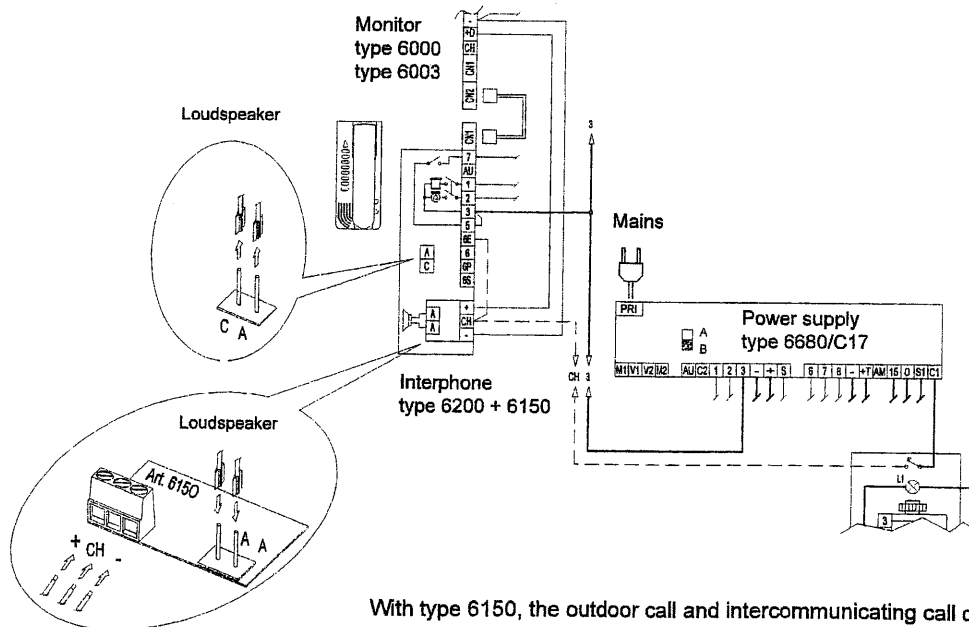

With type 6150, the outdoor call and intercommunicating call cannot be connected.

STANDARD VIDEO DOOR ENTRY SYSTEM WIRING DIAGRAM VERSIONS WITH COAX CABLE

VERSION 11

Wiring diagram of cameras type 558-571 with "Videomoving" device

Cameras with vertical movement type 558 and 571 enable you to control the vertical camera angle using push-button number 1 on the interphone. You can connect any one of the eight additional buttons of type 6152.

This makes it possible to frame people of different heights or to position the entrance panel higher or lower than prescribed.

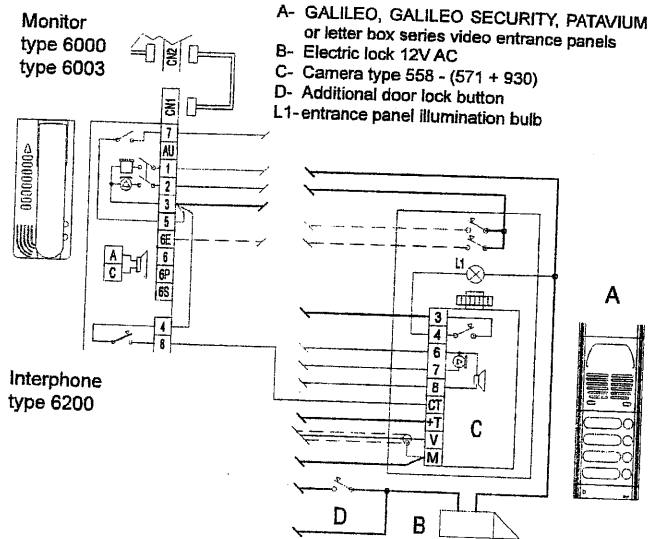

Cameras with vertical movement type 558 and 571 enable you to control the vertical camera angle using the monitor push-button with the symbol . This makes it possible to frame people of different heights or position the entrance panel higher or lower than prescribed.

ton with the symbol . This makes it possible to frame people of different heights or position the entrance panel higher or lower than prescribed.

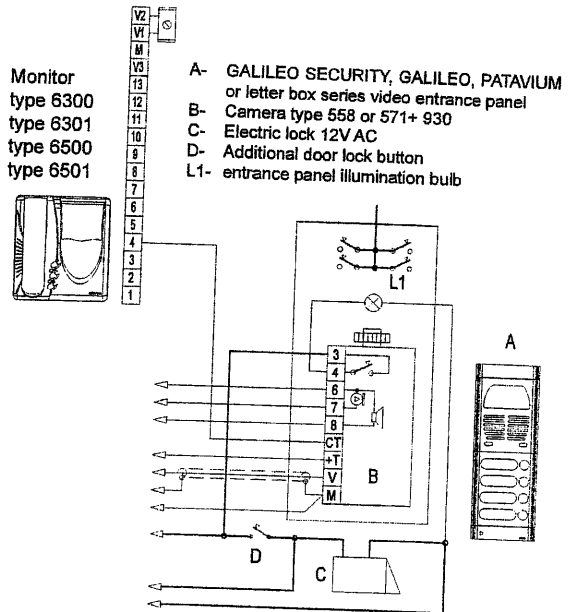

VERSION 12

Wiring diagram for video door entry system with an interphone in parallel, and/or user with interphone without monitor.

N.B.

Can be connected to a maximum of 1 interphone in parallel to a monitor. To connect a larger number, use call repeater type 934 (see version).

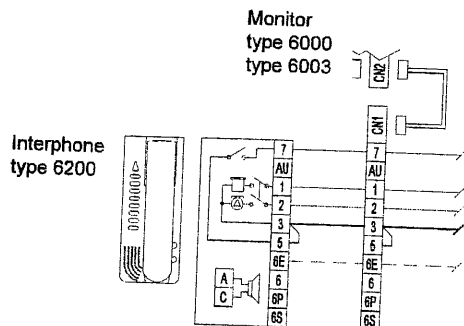

Interphone type 6200 can also be connected without monitor.

Simply do not make the connection between the monitor and the interphone.

A - Connection to user without monitor

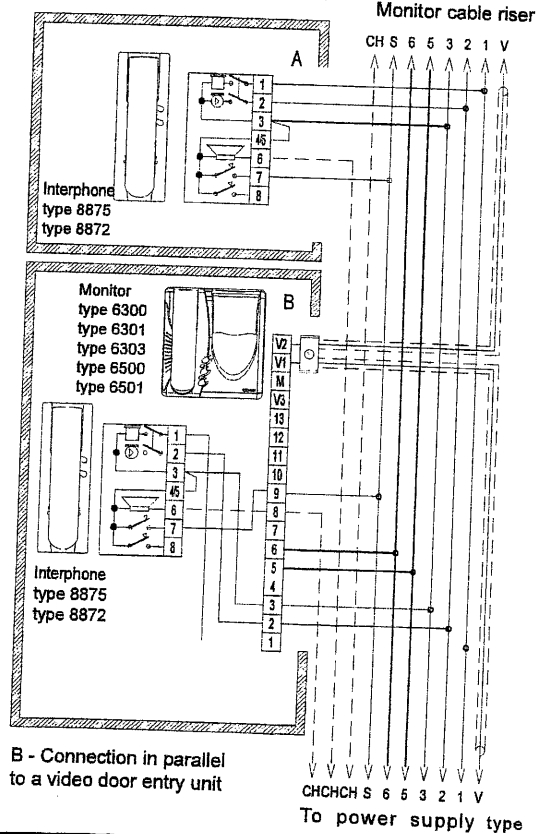

STANDARD VIDEO DOOR ENTRY SYSTEM WIRING DIAGRAM VERSIONS WITH COAX CABLE

VERSION 13

Wiring diagram of call tone level control module with OFF indicator (red LED) and "lock open" indication (green LED) with accessory module type 6153.

DESCRIPTION OF MODULE type 6153

Switching module type 6153 makes it possible to control the call tone volume or disable it, on interphones with call loudspeaker in the PETRARCA series, type 6200 - 6201. The device also has two LED's, one for indicating that the call tone is OFF (red indicator) and one to indicate that the door lock is open (green indicator); the use of these two devices requires additional connections as shown in the wiring diagrams.

INSTALLING THE MODULE ON PETRARCA SERIES INTERPHONES 6200 - 6201

- Open the interphone Fig. 1
- Snap off the plastic lamina by exerting pressure on it (Fig. 1B)
- Insert the card in its seat and fix it with the screw supplied (Fig. 2)
- Disconnect the loudspeaker wire from pin "A" on the interphone.
- Insert the removed wire onto the pin (CN2) on the card type 6153.
- Insert the wire pre-connected to terminal n° 6 of type 6153, on pin "A" of the interphone (Fig. 3)

N.B. On terminal n° 7 of card type 6153, there is a wire to be used for visual indication that the call tone is disabled. In position "0" (call tone OFF) terminals 7 - 10 are connected to the diode, thus enabling the red LED to light.

Wiring diagram of call volume control module without visual indicators

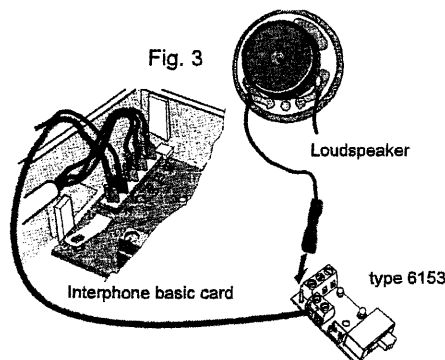
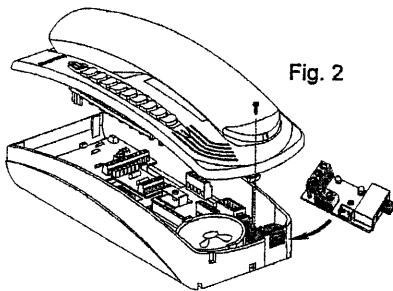
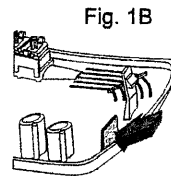
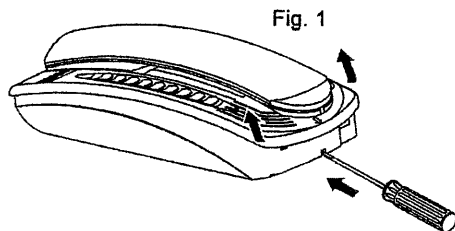
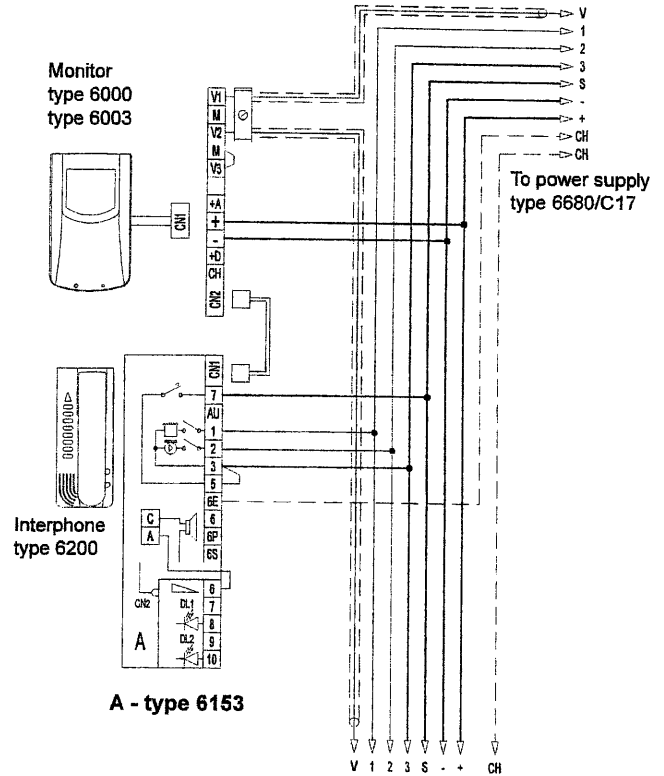

Call tone level selection

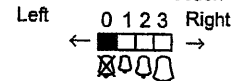

- Position "0": call tone OFF
- Position "1": minimum volume
- Position "2": medium volume
- Position "3": maximum volume

When the call tone OFF visual indicator is used (red LED) as well as the "lock open" indicator (green LED), it is necessary to power these diodes (up to a maximum of 30) with the separate power supply art. 5582/C17. See diagrams on next page.

STANDARD VIDEO DOOR ENTRY SYSTEM WIRING DIAGRAM VERSIONS WITH COAX CABLE

VERSION 14

Wiring diagram of call tone level control module with OFF indicator (red LED) and lock open indicator module (green LED).

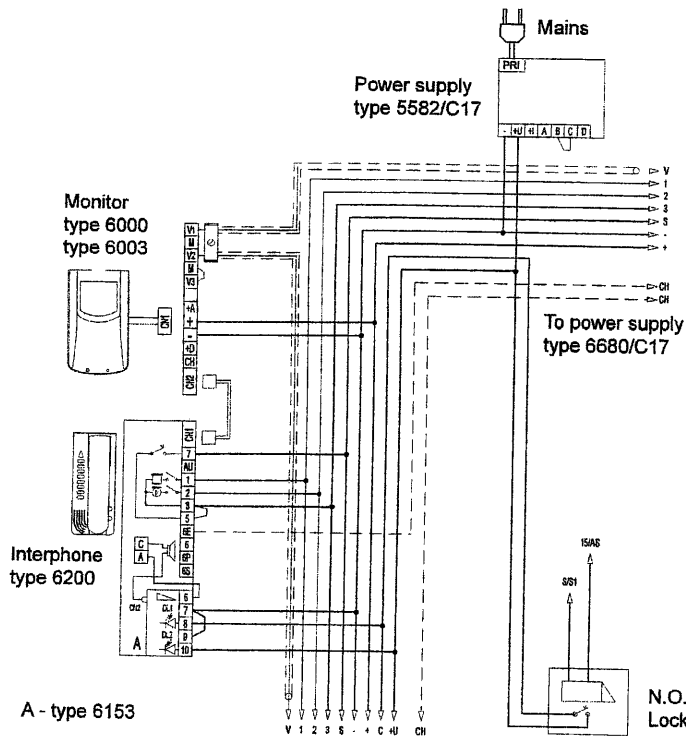

The diagram shows the connection of type 6153 with the call tone OFF (red LED) and lock open (green LED) indicators on interphones type 6200 and monitor type 6000, 6003.

To use just one of the two functions, proceed as follows:

With the call tone OFF indication, connect only the wire to terminal N. 10 of the interphone type 6200. With the "lock open" indicator, connect only terminal N. 8 of the interphone type 6200.

As shown in the diagram, use type 5582/C17 to power the LED's (maximum 30). For more than 30 LED's, use further additional power supplies.

VERSION 15

Wiring diagram of "lock open" visual indication (green LED) with 6300 and 6500 series monitors.

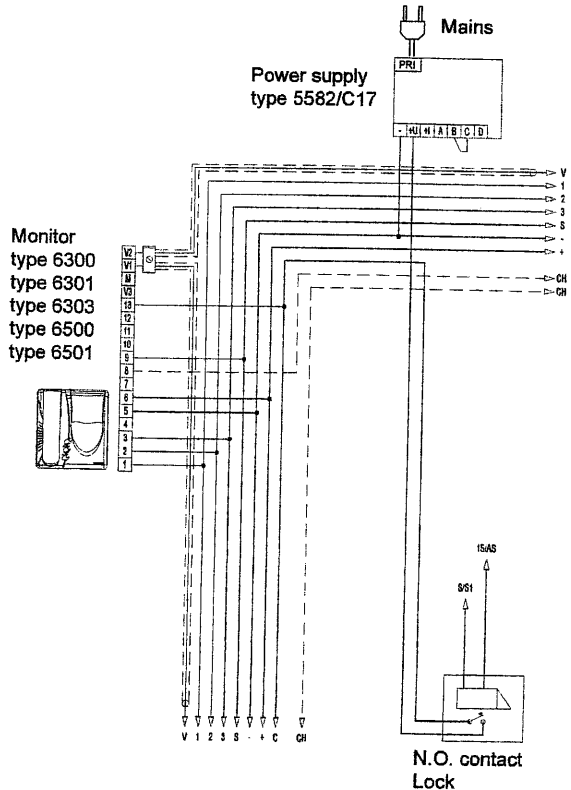

The diagram shows the connection of the "lock open" indicator (green LED) with 6300 and 6500 series monitors (connection to terminal 13).

The call tone OFF indication is already inserted in the monitors and it is not necessary to connect any additional conductor.

To disable the "lock open" indication, do not connect terminal N. 13 of the monitors

The red LED's are powered by the power supply 6680/C17 and must not exceed a total of 20 in number. For larger numbers, use an additional power supply.

As shown in the diagram, use a power supply type 5582/C17 to power the green LED's (maximum 30). For more than 30 LED's, use further additional power

STANDARD VIDEO DOOR ENTRY SYSTEM WIRING DIAGRAM VERSIONS WITH COAX CABLE

VERSION 16

Wiring diagram for the separate camera from the entrance panel with speech unit and additional bulbs for lighting the coverage area.

It is possible to connect an entrance panel with the speech unit only and a separate camera type 5000 - 5020 - 5A20 - 5B20 - 5A10 - 5B10 - 5C10. The illumination bulb must be inserted as shown in the diagram.

The illuminated push-button connected to terminals 3 and 4 of the speech unit type 930 or 930A can be used to switch the entrance panel illumination bulbs on momentarily, as shown in the diagram.

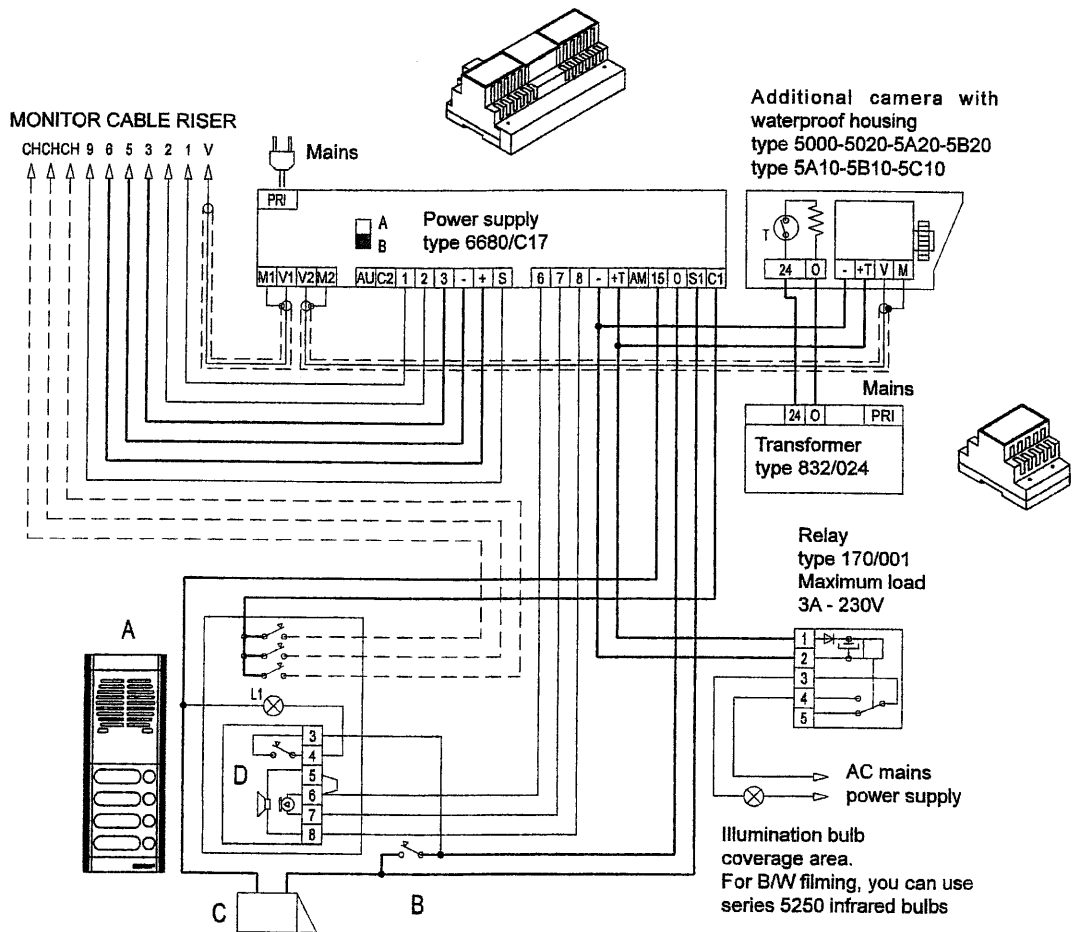

- A- GALILEO SECURITY, PATAVIUM, GALILEO or letter box 2550/302-302 series audio entrance panel
- B- Additional door lock button
- C- Electric lock 12V AC
- D- Speech unit type 930 or 930A
- L1- entrance panel illumination bulb
(3x24V 3W max)
10x24V 3W with type M832
16X24V 3W with type 832/030

STANDARD VIDEO DOOR ENTRY SYSTEM WIRING DIAGRAM VERSIONS WITH COAX CABLE

VERSION 17

Wiring diagram for relay type 170/560 for additional camera switching.

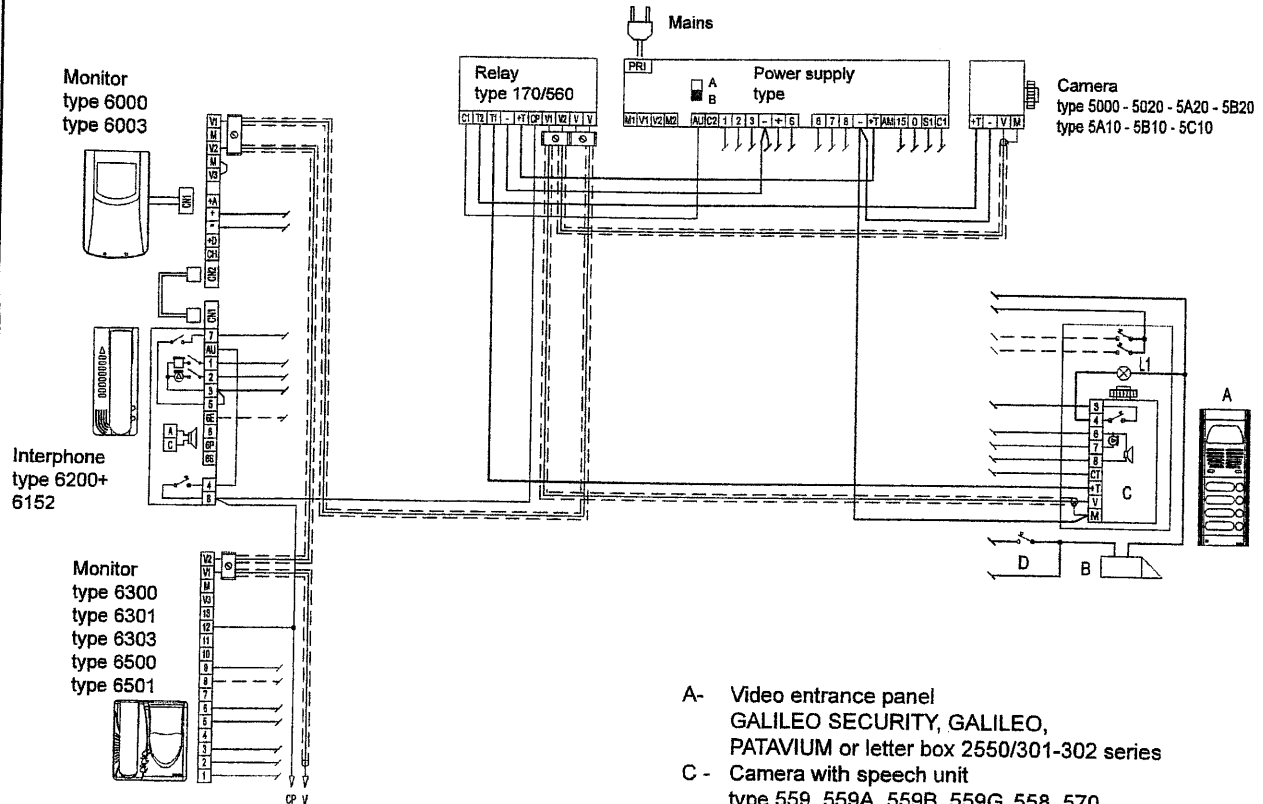

- A- Video entrance panel
GALILEO SECURITY, GALILEO,
PATAVIUM or letter box 2550/301-302 series
- C - Camera with speech unit
type 559, 559A, 559B, 559G, 558, 570,
570G, 571, 559C and 570C
- B- Electric lock 12V
- D- Additional door lock button
- L1- entrance panel illumination bulb
(3x24V 3W max)
10x24V 3W with type M832
16X24V 3W with type 832/030

OPERATION

Relay type 170/560 makes it possible to perform two operations with a single button.

On 6300 and 6500 series monitors, the push-button used has the symbol "□".

On interphones type 6200, use an additional button; the push-button used in the diagram is push-button number 1.

Pressing this push-button enables auto-activation of the system without activating the ringtone. If you keep the push-button pressed down,

you will see the image of the additional camera; when you release it, you will switch to the image of the entrance panel camera.

For night filming, light the viewing series of the secondary camera with an additional bulb, using relay type 170/001. This bulb can be either infrared for B/W filming, or white light type for colour filming.

For the other connections, follow the standard diagrams for power supply type 6680/C17.

STANDARD VIDEO DOOR ENTRY SYSTEM WIRING DIAGRAM VERSIONS WITH COAX CABLE

VERSION 18

Wiring diagram of video entry unit with conversation privacy and door lock release after call.

To provide conversation privacy, fit card type 6155 into interphone type 6200.

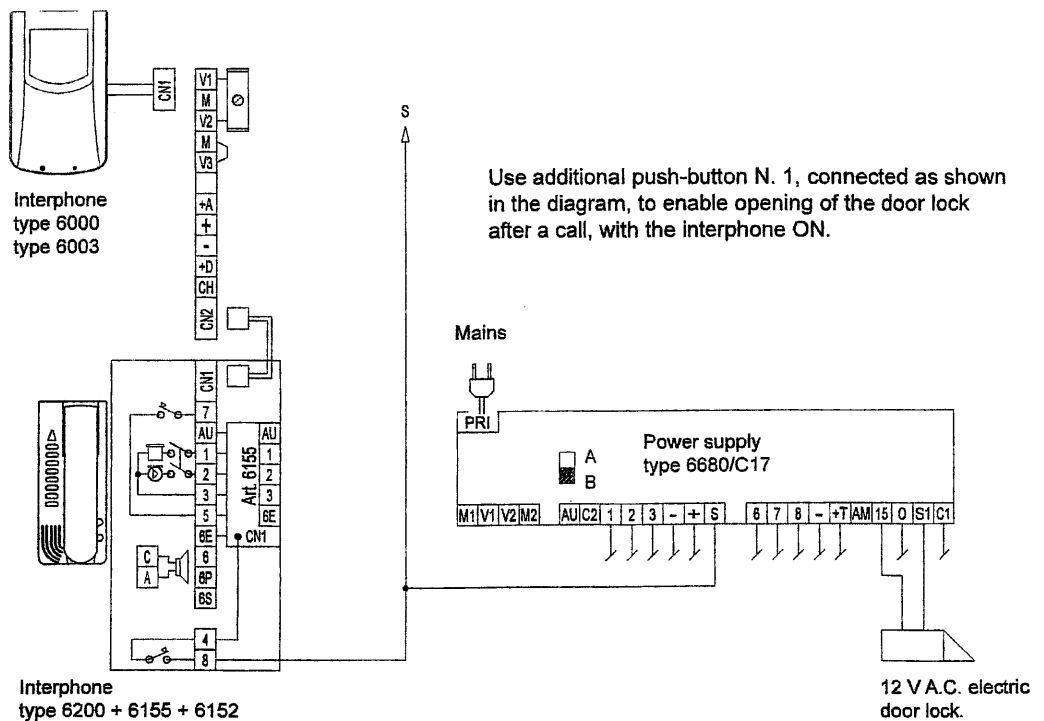
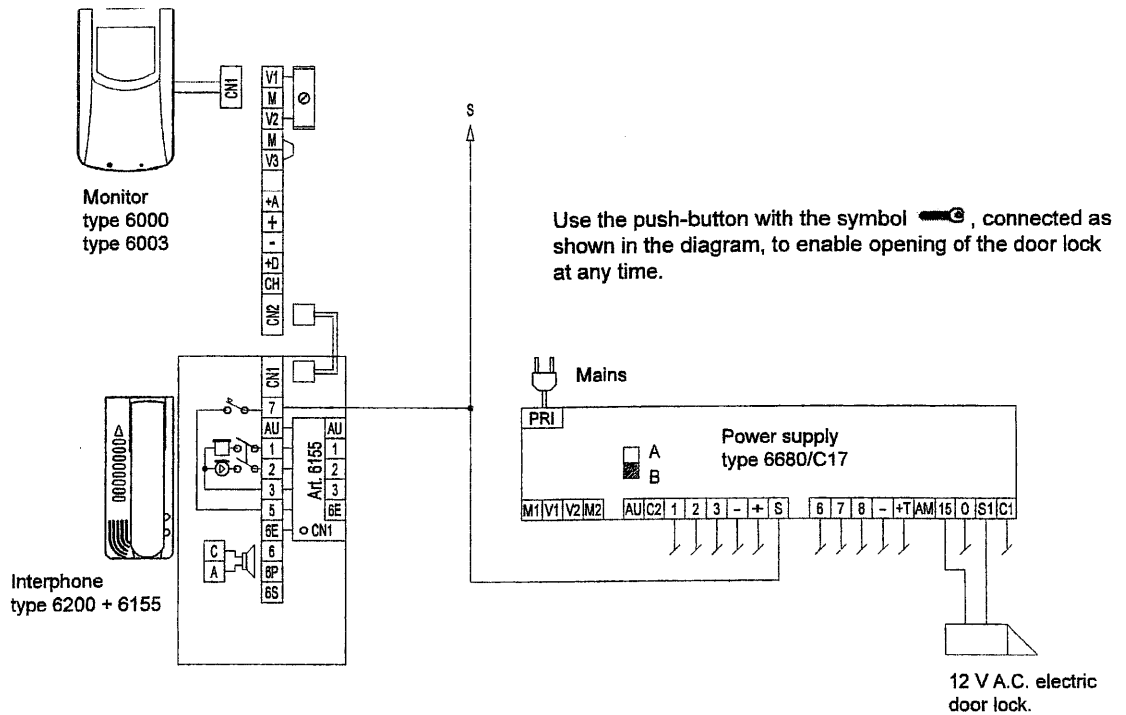

STANDARD VIDEO DOOR ENTRY SYSTEM WIRING DIAGRAM VERSIONS WITH COAX CABLE

VERSION 19

Wiring diagram for video amplifier type 5559.

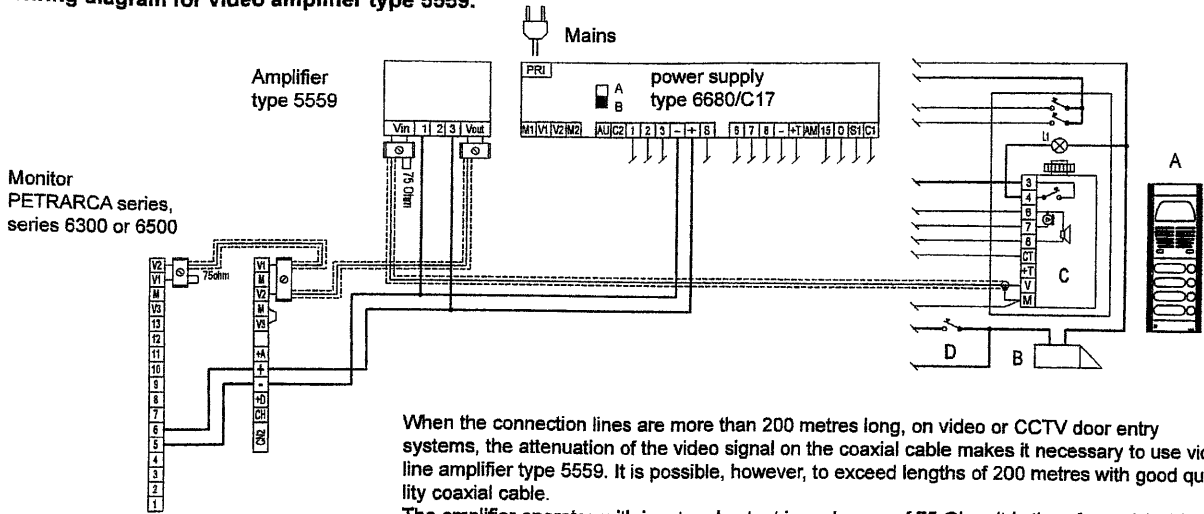

- A- Video entrance panel
GALILEO SECURITY, GALILEO,
PATAVIUM series or letter box
type 2550/301-302
- C - Camera
type 559, 559A, 559B, 559G, 558,
570, 570G, 571, 559C, 570C
- B - Electric lock 12V~
- D- Electric lock button
- L1- entrance panel illumination bulb
(3x24V 3W max)
10x24V 3W with type M832
16X24V 3W with type 832/030

When the connection lines are more than 200 metres long, on video or CCTV door entry systems, the attenuation of the video signal on the coaxial cable makes it necessary to use video line amplifier type 5559. It is possible, however, to exceed lengths of 200 metres with good quality coaxial cable.

The amplifier operates with input and output impedances of 75 Ohm; it is therefore advisable to use RG59 coaxial cable or good quality cables with equivalent impedance. It is advisable to install

the amplifier near the power supply, in a dry, ventilated area. It is possible to install the amplifier on the monitor cable riser; if you do this, however, the amplifier will also amplify any disturbance signals on the video connection line.

The amplifier is equipped with a device which adapts the gain to the length of the line.

It is therefore necessary to move the 3-pin connector to the position corresponding to the line length nearest to the pre-selected values of 200 m, 400 m, 600 m and 800 m. For intermediate line lengths move the 3-pin connector to the position corresponding to the length immediately below the available values; then adjust the gain trimmer P1, until the image has sufficient contrast. Make the connection as shown in the diagram.

Remember to leave in place the 75 Ohm load resistance to the input terminals "IN".

Connect the resistances supplied with the V2-M terminals of the last monitor.

For the other connections, refer to the wiring diagrams for the power supply type 6680/C17.

VERSION 20

Wiring diagram for transformer type M832-832/030 in entrance panels with name tag illumination bulbs

The transformer is used when there are three or more name tag illumination bulbs.

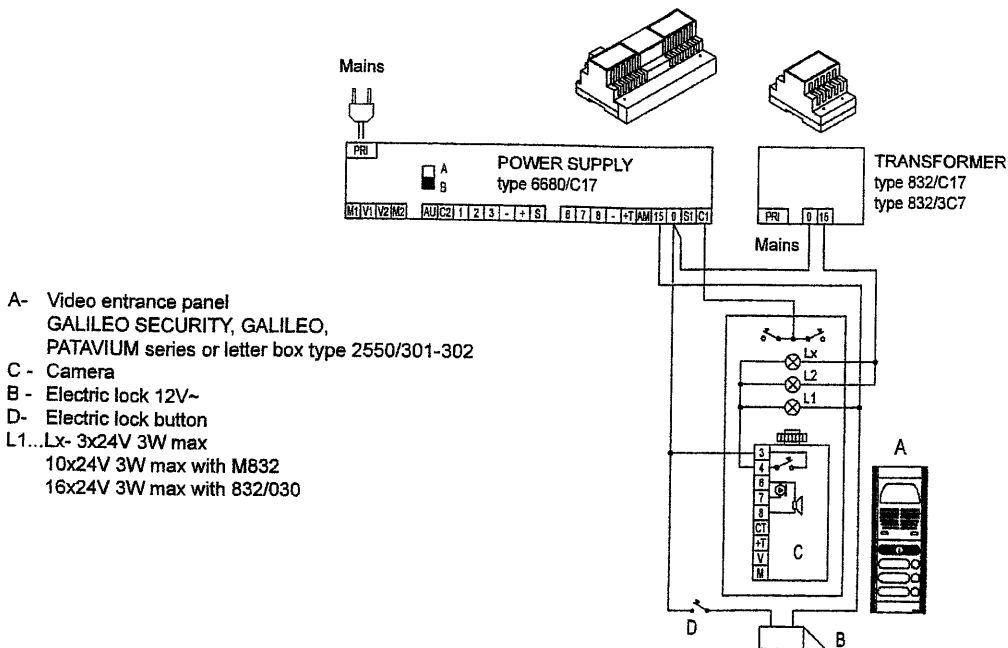

- A- Video entrance panel
GALILEO SECURITY, GALILEO,
PATAVIUM series or letter box type 2550/301-302
- C - Camera
- B - Electric lock 12V~
- D- Electric lock button
- L1...Lx- 3x24V 3W max
10x24V 3W max with M832
16x24V 3W max with 832/030

STANDARD VIDEO DOOR ENTRY SYSTEM WIRING DIAGRAM VERSIONS WITH COAX CABLE

VERSION 21

Wiring diagram of video distributor type 5556/004 for several cable risers.

The video connection must be made using a RG59 type cable or one similar with an impedance of 75 Ohm. 75 Ohm resistors (supplied) must be wired across video outputs V1-V2-V3-V4. These resistors must be wired to the output terminals not used or terminals V2-M on the last riser monitor. A 75 Ohm resistor must also be wired to the "V" voltage-free terminal on the last distributor.

N.B. Video distributor type 5556/004 is equipped with trimmer P1 which simultaneously adjusts the video signal gain at all the outputs. This trimmer is factory-set to 1.

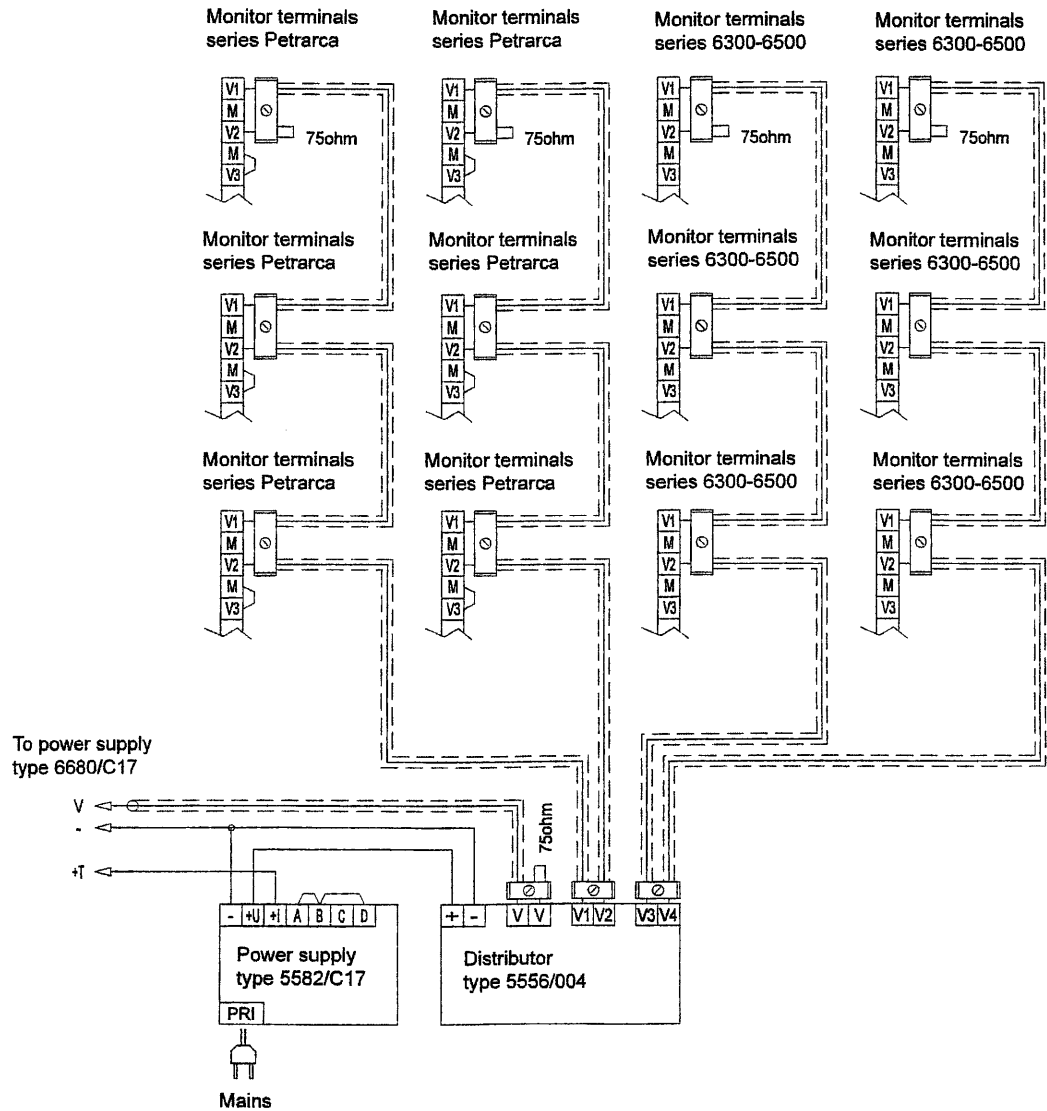

N.B. In power supply type 5582/C17 short circuit terminals A-B-D.

STANDARD VIDEO DOOR ENTRY SYSTEM WIRING DIAGRAM VERSIONS WITH COAX CABLE

VERSION 22

Wiring diagram of video door entry unit and video floor distributor type 5556/004 or type 6554 with monitors series Petrarca.

The wiring diagram only illustrates the monitor cable riser connection to a video floor distributor in a video door entry system. To make the remaining connections, follow the standard wiring diagrams for power supply type 6680/C17, except for the monitor cable riser connection (without video floor distributor) which must be replaced by the one shown in this diagram.

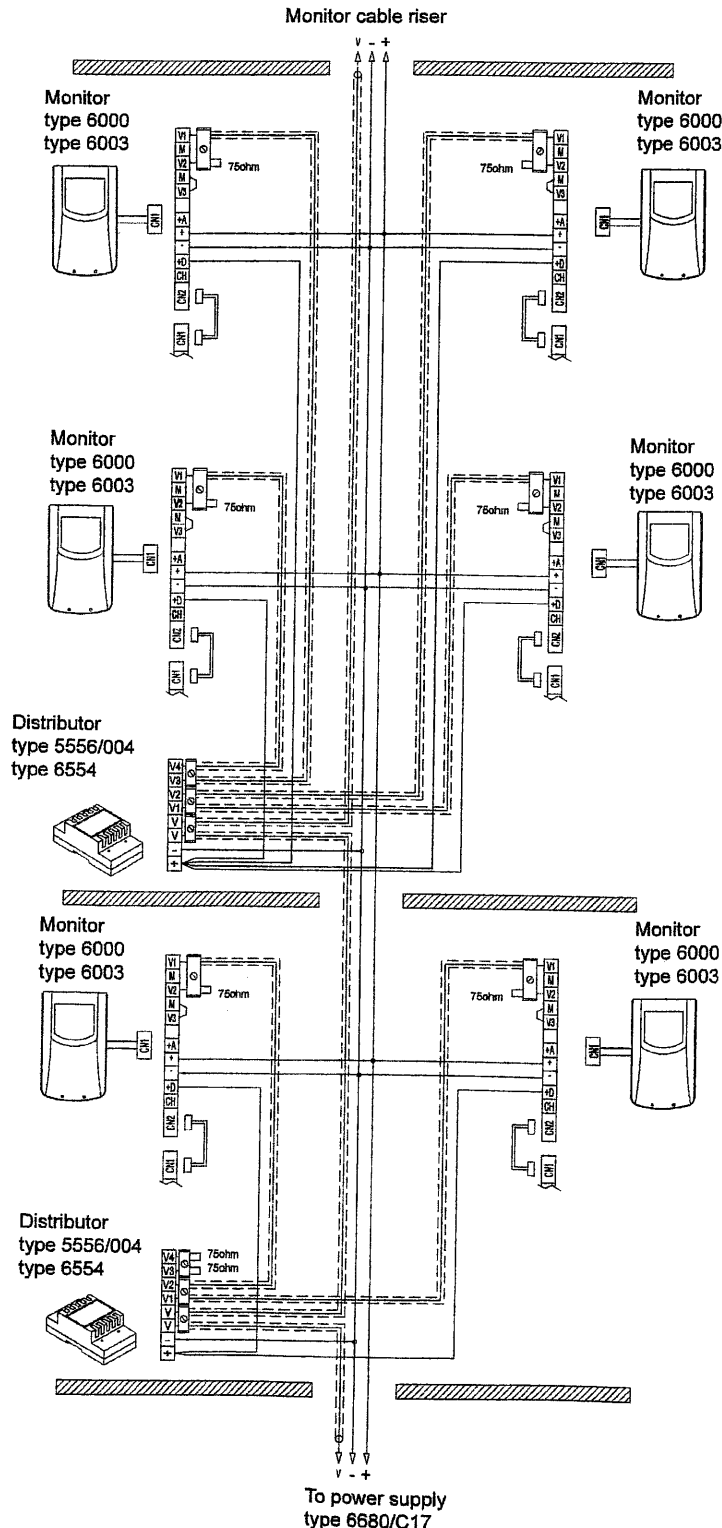

5556/004 e 6554:

75 Ohm resistors (supplied) must be wired across video outputs V1-V2-V3-V4. These resistors must be wired to the output terminals not used or terminals V2-M on the monitor. A 75 Ohm resistor must also be wired to the voltage-free terminal "V" on the last distributor.

N.B. To power the distributors, connect the terminals - and + of the distributor to the - and +D terminals only of the monitors connected to the distributor itself.

IMPORTANT:

Distributor type 6554 can be connected directly to the + and - terminal of the standard power supply instead of +D terminal of the monitor.

In this case, it is possible to insert a maximum of 10 video distributors type 6554 in the same system.

STANDARD VIDEO DOOR ENTRY SYSTEM WIRING DIAGRAM VERSIONS WITH COAX CABLE

VERSION 23

Wiring diagram of video door entry unit and video floor distributor type 5556/004 or type 6554 with monitors series 6300 and 6500.

The wiring diagram only illustrates the monitor cable riser connection to a video floor distributor in a video door entry system. To make the remaining connections, follow the standard wiring diagrams for power supply type 6680/C17, except for the monitor cable riser connection (without video floor distributor) which must be replaced by the one shown in this diagram.

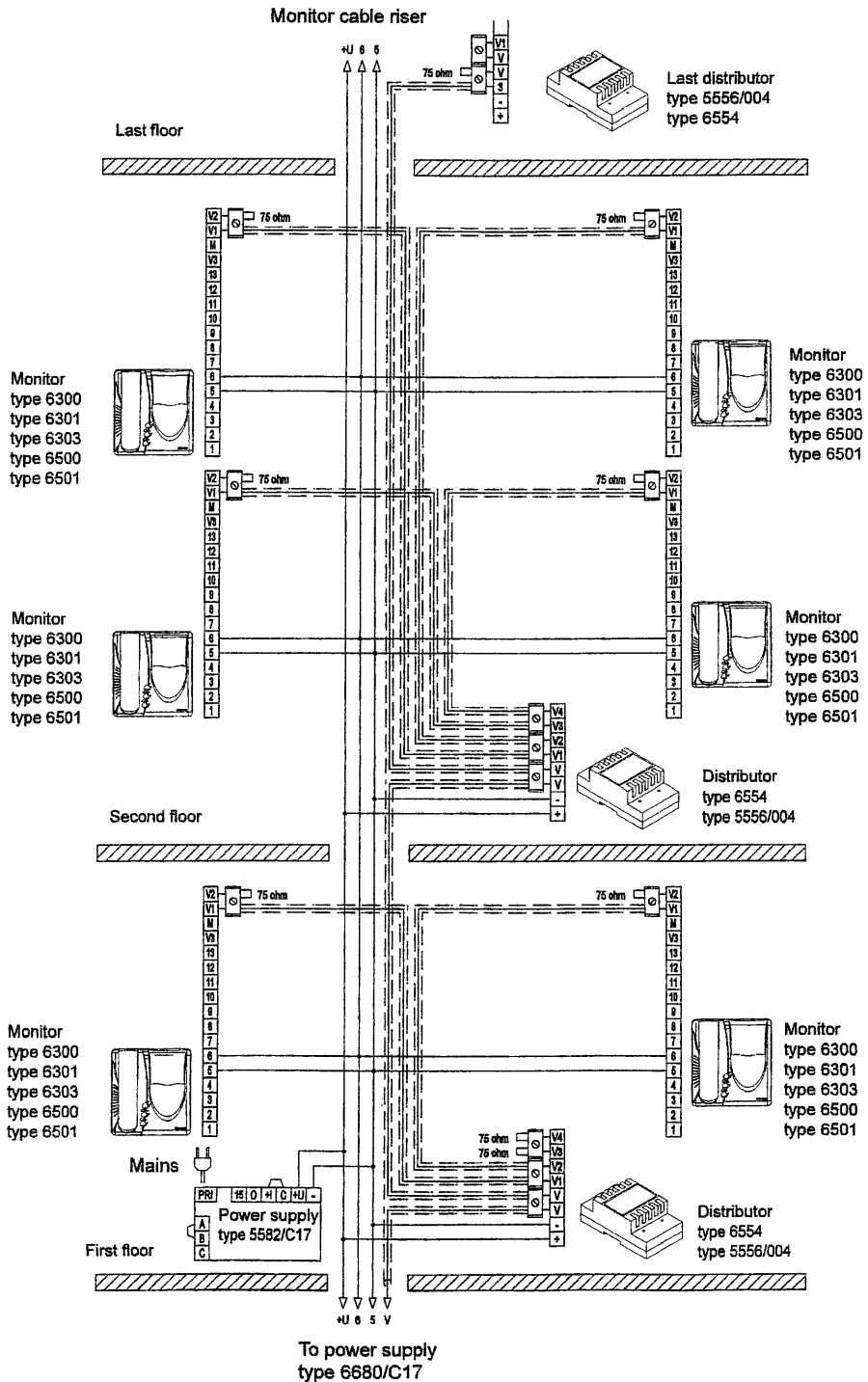

5556/004 e 6554:
75 Ohm resistors (supplied) must be wired across video outputs V1-V2-V3-V4. These resistors must be wired to the output terminals not used or terminals V2-M on the monitor. A 75 Ohm resistor must also be wired to the voltage-free terminal "V" on the last distributor.

IMPORTANT:
The power supply type 6583 can power up to a maximum of 12 distributors 5556/004 or 30 distributors 6554; if further distributors are needed, use further 6583 units.