



ALPHA-PAGE v4.1
Nurse Call/Emergency Call Pocket Paging System

installation/owners manual #APV41125

Alpha Communications®
Toll Free Phone 1-800-666-4800

***** NOTICE *****

The Alpha-Page digital pager interface system is an extremely reliable system for sending nurse call and other alarm messages to pocket pagers. The system sends messages to your pager(s) using a relatively high power radio signal. This signal has considerable range and has the ability to reject radio "noise" which could corrupt the message being sent.

Although Alpha-Page is extremely reliable in communicating messages, it must only be used as supplemental call annunciation in life safety applications such as nurse call/emergency call. Alpha-Page should only be used to enhance the efficiency of a wired nurse call system. There should be a system of call lights and audible alarms in place as the primary means of call annunciation in nurse call/emergency call applications. Notification of patient calls to staff members shall be the responsibility of the nurse call system. Micro Logic Systems shall not be held liable for incidental or consequential damages resulting from the call annunciation failure.

INTRODUCTION

Alpha-Page is a nurse call monitoring system designed to instantly send user programmed messages to alphanumeric pocket pagers. The system is stand-alone, it does not require a computer or any other equipment. Alpha-Page is designed to interface to systems utilizing a call wire (annunciator wire) per room (or patient).

Alpha-Page uses alphanumeric pocket pagers which can receive messages containing numbers, letters, and punctuation symbols. You program a specific message for each room using a standard PS-2 computer keyboard. Therefore, the call message on a staff member's pager tells exactly who is calling and from which room. The system can be configured to best meet the needs of the facility. For example, the system can contain several pagers that can each receive all patient calls. Or, several pagers may be used but each only receives calls assigned to a specific staff member. Alpha-Page contains a timer for each call. If a call isn't answered/reset within a programmable period of time, the page can be re-sent to the same pager number or to a different/back-up pager number.

User programming is protected from erasure due to power failure with a built-in lithium battery with a life-span of up to ten years. With the rechargeable 12V, 7 Amp-hour battery option, the Alpha-Page system operates with battery back-up for up to 36 hours. When main power is restored, the battery is automatically recharged. Note: The TX125-ENC operates on a separate power supply. For system operation during a power failure, the PS-125 power supply (for TX125-ENC) must be plugged into a UPS or similar power outlet with power backup.

MLS-EC1 ENCLOSURE INSTALLATION

The entire Alpha-Page system (except transmitter and pagers) fits in the MLS-EC1 surface-wall mount enclosure. Determine a suitable location for the MLS-EC1. Remember, one wire for each room (or patient) needs to be run to the MLS-EC1. This can come directly from a room station, from a corridor light or, if there is an annunciator panel (light board where all calls appear), one wire for each room can be run from the annunciator panel to the MLS-EC1 enclosure. Locate the MLS-EC1 in a location that will allow the most convenient means of running the required wiring between the nurse call system and Alpha-Page. Refer to drawings C022397-1 and C022397-2 for enclosure dimensions and mounting hole locations.

ROOM WIRING

Each signal wire that is to cause a message to be transmitted must be connected to a MLS-32L signal input board. The signal may come directly from a room station, from a corridor dome light, or can be parallel connected to the call light/LED of the annunciator panel (light board showing all calls). The annunciator panel is usually located at the nurses station. Refer to drawings in this manual for basic wiring schematics. Note that there must be a connection between the nurse call power supply and the "COM" terminal of the MLS-SPU1 board. If the nurse call system is the common negative type (positive is switched to place call), then nurse call power supply negative (-) must be connected to the "COM" terminal of the MLS-SPU1 board. If the nurse call system is the common positive type (negative is switched to place call), then nurse call power supply positive (+) must be connected to the "COM" terminal of the MLS-SPU1 board.

Alpha-Page can monitor up to 256 rooms. Each MLS-32L signal input board can accommodate 32 inputs. Therefore, more than one MLS-32L board is required if more than 32 inputs are being monitored, up to eight can be used. The system can be expanded at any time by

simply adding additional MLS-32L boards. Each MLS-32L board is programmed with an "address" (1-8) which identifies it from the other MLS-32L boards. Programming is accomplished by placing a programming jumper over stake-pin pair 1-8 on the MLS-32L board (refer to drawing C022397-3). Later, you will program each input with its own message. When programming messages, inputs are identified on the liquid crystal display (LCD) as input 001-input 256. These will correspond to terminals on MLS-32L boards. Terminals 1-32 on the MLS-32L board addressed as #1 will correspond to input 001-input 032. Terminals 1-32 on the MLS-32L board addressed as #2 will correspond to input 033-input 064, respectively. Refer to the chart Relationship between MLS-32L terminal number, MLS-32L board number and programming input number for a complete reference guide. **Installer: Make note of which call station is wired to each MLS-32L input using the charts located in this manual.**

Room wiring is connected to pluggable terminal blocks on the MLS-32L boards, refer to drawing C030497-1. MLS-32L boards are plugged into the MLS-32L sockets of the MLS-SPU1 board, refer to drawings C022397-4 and C030297-1. Any MLS-32L board number (address) may be plugged into any of the eight sockets on the MLS-SPU1, the order does not matter. MLS-32L boards are held securely in place by #6-32 mounting screws going through the "L" brackets of the MLS-32L and into the MLS-32L mounting posts located in the MLS-EC1 enclosure.

CONNECTING TX125-ENC TRANSMITTER

Refer to drawing #C091905-1 for connection/wiring instructions for the paging transmitter. Note that the paging data will come out of the COM1 serial port of the MLS-SPU1 processor board. The data will go through two MLS-485's, then after a protocol conversion will be feed into the TX125-ENC paging transmitter. The MLS-485 devices also function as short-haul modems. This means that the paging transmitter may be located remotely from the MLS-SPU1 processor board by up to 2,500'. This may be useful for locating the transmitter in a central (and high location in multi-story buildings) to achieve optimum paging coverage. One MLS-485 will be located near the MLS-SPU1, (use the modular cable and DB9-MOD6-1 adapter to connect this MLS-485 to the MLS-SPU1), the second MLS-485 will be installed at whatever location is chosen for the TX125-ENC transmitter. (Use the PTIP-MOD-3 adapter to connect this MLS-485 to the TX125-ENC transmitter.) Two pair of unshielded 22 gauge wire is required between the MLS-485's. Note that the MLS-485's will be powered from the 12VDC power output of the MLS-SPU1 board. **MAKE SURE to observe voltage polarity when connecting power to the MLS-485's.**

Notice that the two MLS-485's have a mode switch coming out of the end panel. Refer to drawing #C091905-1 for the correct mode switch position for each MLS-485. Also notice that each MLS-485 has different firmware installed in it's processor board. The firmware version in each MLS-485PC is indicated on a label on the bottom of the unit. Again refer to drawing #C091905-1 for the proper location (at MLS-SPU1 or at TX125-ENC paging transmitter) for each MLS-485. The MLS-485 that connects to the MLS-SPU board has 485PCTX5 firmware, the MLS-485 that connects to the TX125-ENC transmitter has 485PCR5X5 firmware. Use the supplied Velcro to mount this MLS-485 next to the TX125-ENC. Mount the TX125-ENC using the four holes/slots. You provide the mounting screws depending on what type of surface the TX125-ENC is being mounted to. Mount the TX125-ENC with the antenna oriented vertically.

Relationship between MLS-32L terminal number, MLS-32L board number
and programming input number

	MLS-32L board number							
	#1	#2	#3	#4	#5	#6	#7	#8
terminal:								
1	001	033	065	097	129	161	193	225
2	002	034	066	098	130	162	194	226
3	003	035	067	099	131	163	195	227
4	004	036	068	100	132	164	196	228
5	005	037	069	101	133	165	197	229
6	006	038	070	102	134	166	198	230
7	007	039	071	103	135	167	199	231
8	008	040	072	104	136	168	200	232
9	009	041	073	105	137	169	201	233
10	010	042	074	106	138	170	202	234
11	011	043	075	107	139	171	203	235
12	012	044	076	108	140	172	204	236
13	013	045	077	109	141	173	205	237
14	014	046	078	110	142	174	206	238
15	015	047	079	111	143	175	207	239
16	016	048	080	112	144	176	208	240
17	017	049	081	113	145	177	209	241
18	018	050	082	114	146	178	210	242
19	019	051	083	115	147	179	211	243
20	020	052	084	116	148	180	212	244
21	021	053	085	117	149	181	213	245
22	022	054	086	118	150	182	214	246
23	023	055	087	119	151	183	215	247
24	024	056	088	120	152	184	216	248
25	025	057	089	121	153	185	217	249
26	026	058	090	122	154	186	218	250
27	027	059	091	123	155	187	219	251
28	028	060	092	124	156	188	220	252
29	029	061	093	125	157	189	221	253
30	030	062	094	126	158	190	222	254
31	031	063	095	127	159	191	223	255
32	032	064	096	128	160	192	224	256

CONNECTING POWER TO ALPHA-PAGE

Alpha-Page receives primary power from a 12VAC, 20VA power transformer. DO NOT use any power transformer with a secondary voltage rating of anything other than 12VAC. Connect the transformer secondary terminals to the two "AC" terminals on the MLS-SPU1 board, polarity does not matter. Use 18 AWG wire. Refer to drawing C022397-5. If the 12V, 7 amp-hour battery is to be used (for power back-up) it should be connected according to drawing C022397-5. Make sure the red wire of the MLS-H1 battery cord (included with battery) is connected to the positive (+) terminal of the battery via the quick-disconnect connector. The black wire of the MLS-H1 battery cord must be connected to the negative (-) terminal of the battery. The other end of the MLS-H1 cord is connected to the MLS-SPU1 board. Connect the red wire to the "B+" terminal. Connect the black wire to the "B-" terminal. MLS-H1 may be factory connected. Place the battery in the battery tray located in the bottom, center of the MLS-EC1 enclosure.

MESSAGE PROGRAMMING

A nurse call paging system would be of little use if the messages being sent to pagers could not be user programmed to include information such as a patients name and the exact location (room number) the patient is calling from. Alpha-Page allows you to program a specific message for each room that will be sent to your pagers when a call is placed.

Before the user does any custom message programming, the system contains generic programming which allows the system to function immediately without needing to be programmed. Input 1 is programmed as "Input 001", input 2 as "Input 002", etc. The system will be much more useful with your custom programming.

To enter the programming mode, simply plug a standard "PS/2" type computer keyboard into the keyboard receptacle located on the MLS-SPU1 board (see drawing C022397-4). The programming screen appears on the LCD display automatically. The top two rows comprise the message field. This is where messages (up to 40 characters) will be entered. You may enter any number, any letter (upper and lower case, use shift for upper case), and most punctuation symbols. Some keys on the keyboard will not function. To update a message, simply type over the old message. Use the <backspace> key to move the cursor back one position. Use the <space bar> to erase the character located at the cursor position.

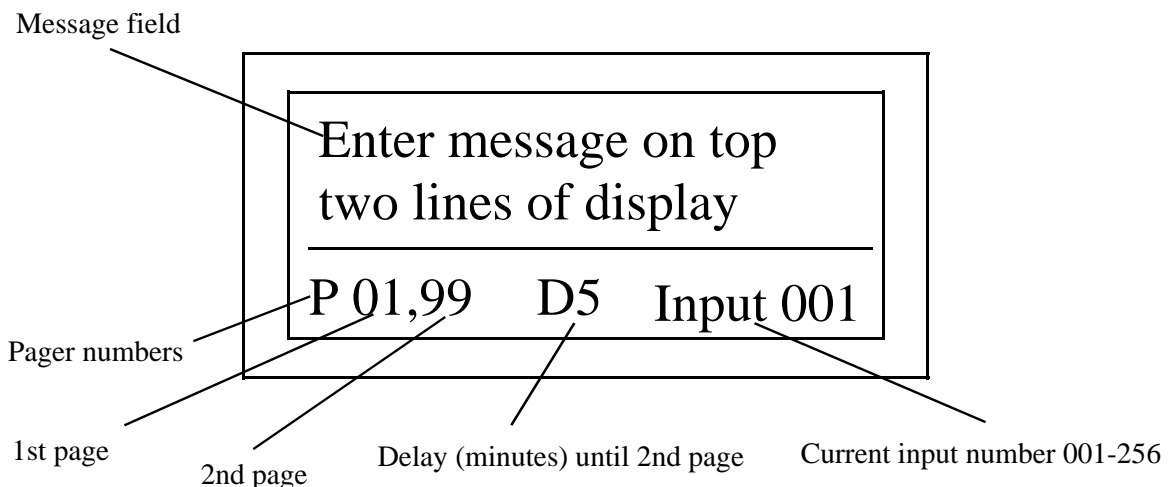

Assigning Pager Numbers

The "pager" field is located at the lower left of the LCD. Use the <tab> key to move the cursor from the message field to the pager field. Pagers are factory programmed with one or more 7 digit "capcodes." Factory programmed capcodes are printed on the back of each pager. **Note: All capcodes must begin with "08782."** The "pager number" is the last 2 digits of the 7 digit capcode. You assign a pager number (or numbers) to each message which determines which pager(s) receive the message. For example, a message with assigned pager number 01 will only go to pagers programmed with pager number 01. Pager group numbers may be setup. Several (or all) pagers can contain the same pager number. Assigning that common (group) pager number to a message sends that message to ALL pagers in that group. Move the cursor to the "pager" field on the LCD and type the desired pager numbers for each message. To erase or change a pager number, simply type over it. The first pager number (before the comma) is the pager number that is paged immediately when a patient call is received by Alpha-Page. The repeat pager number (after the comma) is paged IF the call remains unanswered for a period of time (minutes) specified in the *delay* field. See *Repeat Page Delay*. Alpha-Page accepts pager numbers in the range of 00-99. The default pager number for the first and repeat page is 01.

Repeat Page delay

Alpha-Page can send a second (and repeating) page for a call if the call isn't cancelled within a specified time period. Use the <tab> key to move the cursor from the pager field to the delay field. Enter a number (minutes) in the range 0-9. If zero minutes is selected, there will be no repeat pages regardless of the length of the call. Selecting zero allows you to disable the repeat page feature if desired. The default delay for each input is set to zero. **If a repeat page delay is programmed (1-9), Alpha-Page will continue to repeat the page at the specified interval (1 to 9 minutes) for as long as the call is present.**

Programming Another Input

To program the message, pager number(s) and repeat page delay for another Alpha-Page input (patient call station), use the <tab> key to move the cursor to the "INPUT" field located at the lower right of the LCD. Type the number of the input that you wish to program/edit. Only input numbers in the range 001-256 will be accepted. Once a valid input number is entered, the current message, pager numbers and repeat page delay for that input immediately appears on the LCD display. Use the <tab> key to move the cursor to the message field. Continue programming following the directions above.

When all programming/editing is complete, unplug the computer keyboard. The system will resume monitoring for calls and sending call messages to pagers. Programming can be edited at any time by again plugging in a keyboard and following to procedure above. Your programming is protected from erasure due to power failure by a built-in lithium battery.

NORMAL OPERATION

When a call is placed by a patient on his/her call station, your programmed message for that room (for example, "Mr. Jones, room 118") is immediately transmitted to the specified pager(s) (first page) . **If the call was placed from a call station that causes the nurse call light to flash (bathroom emergency call station, for example) your programmed message will be transmitted immediately to the specified pager(s) and preceded by "Priority-" (for example, "Priority-Mr. Jones, room 188")**. If the call remains unanswered/ not cancelled long enough to activate the second/repeat page (delay specified during programming), and the specified delay isn't "0", the second page is sent to the specified pager(s) after the specified number of minutes has passed and will be repeated at the specified interval for as long as the call is present.

An "S" will appear on the lower left corner of the LCD when the system is sampling (looking for calls on the MLS-32L input boards). This indicates normal operation.

"CALL CANCELED" PAGE

As an option, Alpha-Page can send a page when a call/alarm is canceled. To enable this feature, enter the programming mode by plugging a PS/2 keyboard into the keyboard receptacle located on the MLS-SPU1 board. <TAB> to the "input" field and go to input 256. <TAB> to the message field. Enter a lower case "c" as the first character on the top line of the message field (doesn't matter what, if anything, else exists in the message field for input 256). Remove the keyboard to resume normal operation. Now when any call/alarm is canceled, the programmed message for that input number is paged, preceded by "canceled-". The page is sent to the pager number specified as "1st page" for that input number (see Message Programming, page 6).

PAGER MEMORY

Messages sent to pagers are stored in the memory of the pager. This memory can become full. When this occurs, older messages are overwritten by new messages. You may wish to erase messages right after they have been viewed or erase all messages occasionally. Follow the directions included with the pager.

MAINTENANCE

Alpha-Page is virtually maintenance free. The optional 12V, 7 amp-hour battery used for power back-up may lose some of its capacity after approximately five years of use. It may be required at that time to replace the battery to maintain the full 36 hour power back-up capacity. It is recommended that the 3V lithium battery used for memory back-up (see drawing C022397-4) be replaced every five years to ensure proper system operation. The battery is contained in a battery holder and is easily replaceable. Replace with Panasonic type CR2025 or equivalent (3V, 150mAh, 20 mm diameter).

GENERAL

When power is applied to Alpha-Page, a memory test is conducted. If a problem is found, "Memory Fail" will appear on the LCD screen.

TROUBLESHOOTING

Symptom:

System is dead, LCD screen is blank.

Possible causes:

Blown fuse in 12VAC transformer-replace transformer, do not short secondary terminals together.

Thermal fuse on MLS-SPU1 board triggered-check for and remove short circuit between "+12" and "GND" terminals of MLS-SPU1 board.

Symptom:

Call placed, no message sent to pager.

Possible causes:

"COM" terminal of MLS-SPU1 board not connected, or not properly connected-refer to drawings in this manual for wiring assistance.

The pager number assigned to the message does not match actual pager number. The pager number is the last 2 digits of the capcode which appears on the back of the pager. (see MESSAGE PROGRAMMING).

The first 5 digits of the pager capcode are not "08782". All pages sent by this version of Alpha-Page are programmed to be sent to pager capcodes beginning with "08782". If MLS did not provide your pagers, make sure the pagers are programmed correctly.

Programming keyboard is plugged in, when keyboard is plugged in, system is in programming mode and is not monitoring for calls-when finished programming, unplug keyboard.

TX125-ENC transmitter is too far away from pagers-relocate transmitter centrally in building (see drawing C091905-1).

TX125-ENC transmitter isn't properly connected to the MLS-SPU1, refer to "Connecting TX125-ENC Transmitter" section of this manual and drawing C091905-1.

Symptom:

No transmitter CTS" appears on the LCD screen.

Possible causes:

At power-up/reset, Alpha-Page does a self-test of the MLS-485's, Alpha-Page does not see the MLS-485's. Refer to "Connecting TX125-ENC Transmitter" section of this manual and drawing C091905-1.

input number	Room/station
1	
2	
3	
4	
5	
6	
7	
8	
9	
10	
11	
12	
13	
14	
15	
16	
17	
18	
19	
20	
21	
22	
23	
24	
25	
26	
27	
28	
29	
30	
31	
32	

input number	Room/station
33	
34	
35	
36	
37	
38	
39	
40	
41	
42	
43	
44	
45	
46	
47	
48	
49	
50	
51	
52	
53	
54	
55	
56	
57	
58	
59	
60	
61	
62	
63	
64	

input number	Room /station
65	
66	
67	
68	
69	
70	
71	
72	
73	
74	
75	
76	
77	
78	
79	
80	
81	
82	
83	
84	
85	
86	
87	
88	
89	
90	
91	
92	
93	
94	
95	
96	

input number	Room /station
97	
98	
99	
100	
101	
102	
103	
104	
105	
106	
107	
108	
109	
110	
111	
112	
113	
114	
115	
116	
117	
118	
119	
120	
121	
122	
123	
124	
125	
126	
127	
128	

input number	Room/station
129	
130	
131	
132	
133	
134	
135	
136	
137	
138	
139	
140	
141	
142	
143	
144	
145	
146	
147	
148	
149	
150	
151	
152	
153	
154	
155	
156	
157	
158	
159	
160	

input number	Room/station
161	
162	
163	
164	
165	
166	
167	
168	
169	
170	
171	
172	
173	
174	
175	
176	
177	
178	
179	
180	
181	
182	
183	
184	
185	
186	
187	
188	
189	
190	
191	
192	

input number	Room/station
193	
194	
195	
196	
197	
198	
199	
200	
201	
202	
203	
204	
205	
206	
207	
208	
209	
210	
211	
212	
213	
214	
215	
216	
217	
218	
219	
220	
221	
222	
223	
224	

input number	Room/station
225	
226	
227	
228	
229	
230	
231	
232	
233	
234	
235	
236	
237	
238	
239	
240	
241	
242	
243	
244	
245	
246	
247	
248	
249	
250	
251	
252	
253	
254	
255	
256	

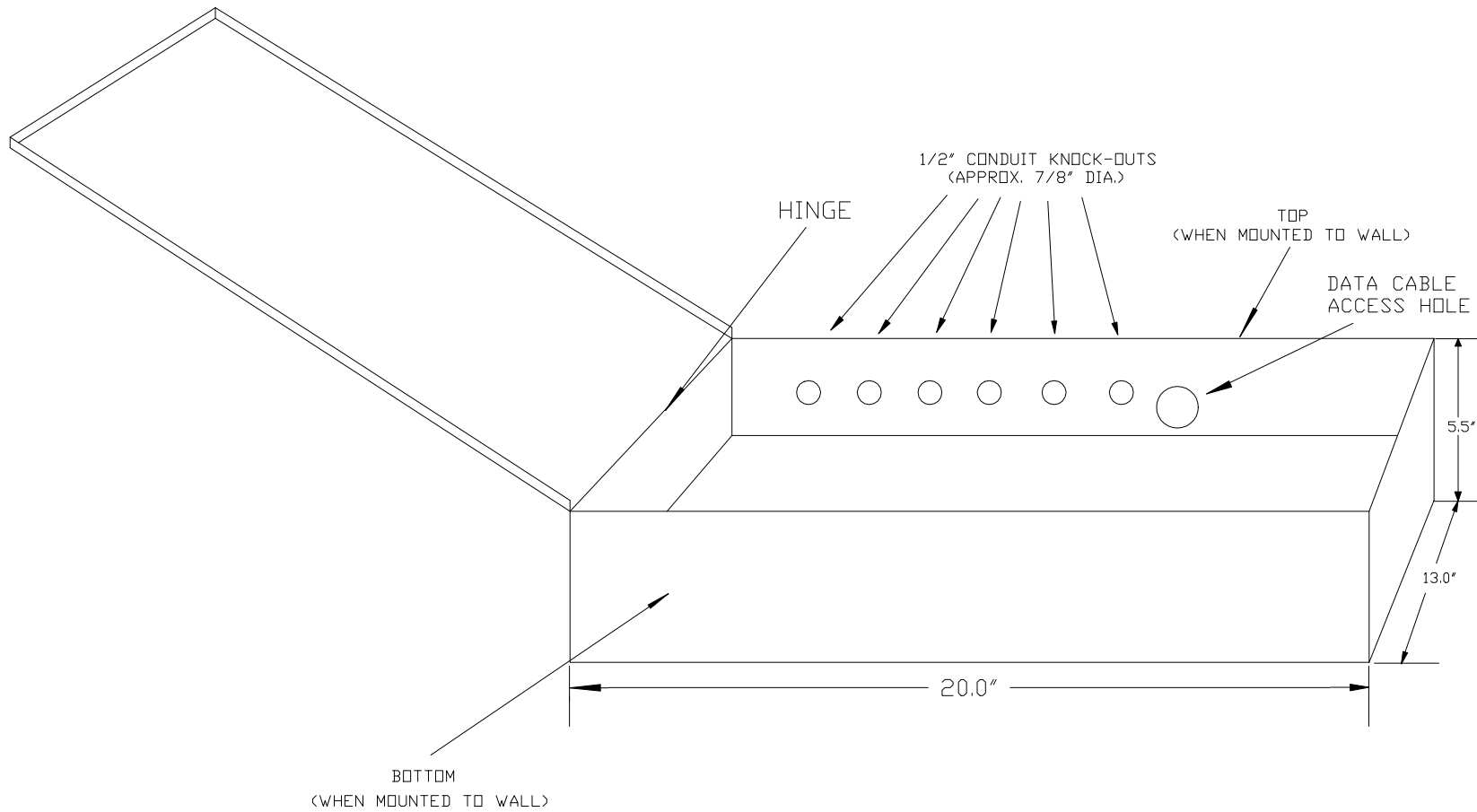

NOTE:
 ENCLOSURE CONTAINS MAGNETIC COVER LATCH
 AND COVER OPENING KNOB.

TITLE		MLS-EC1 ENCLOSURE DIMENSIONS	
NUMBER	C022397-1	REVISION	C
		ORIG. SIZE	A
DATE: 2/23/97	REV. 9/21/98	SHEET	1 OF 1
FILE: EC1-DIMS		DRAWN BY:	MG

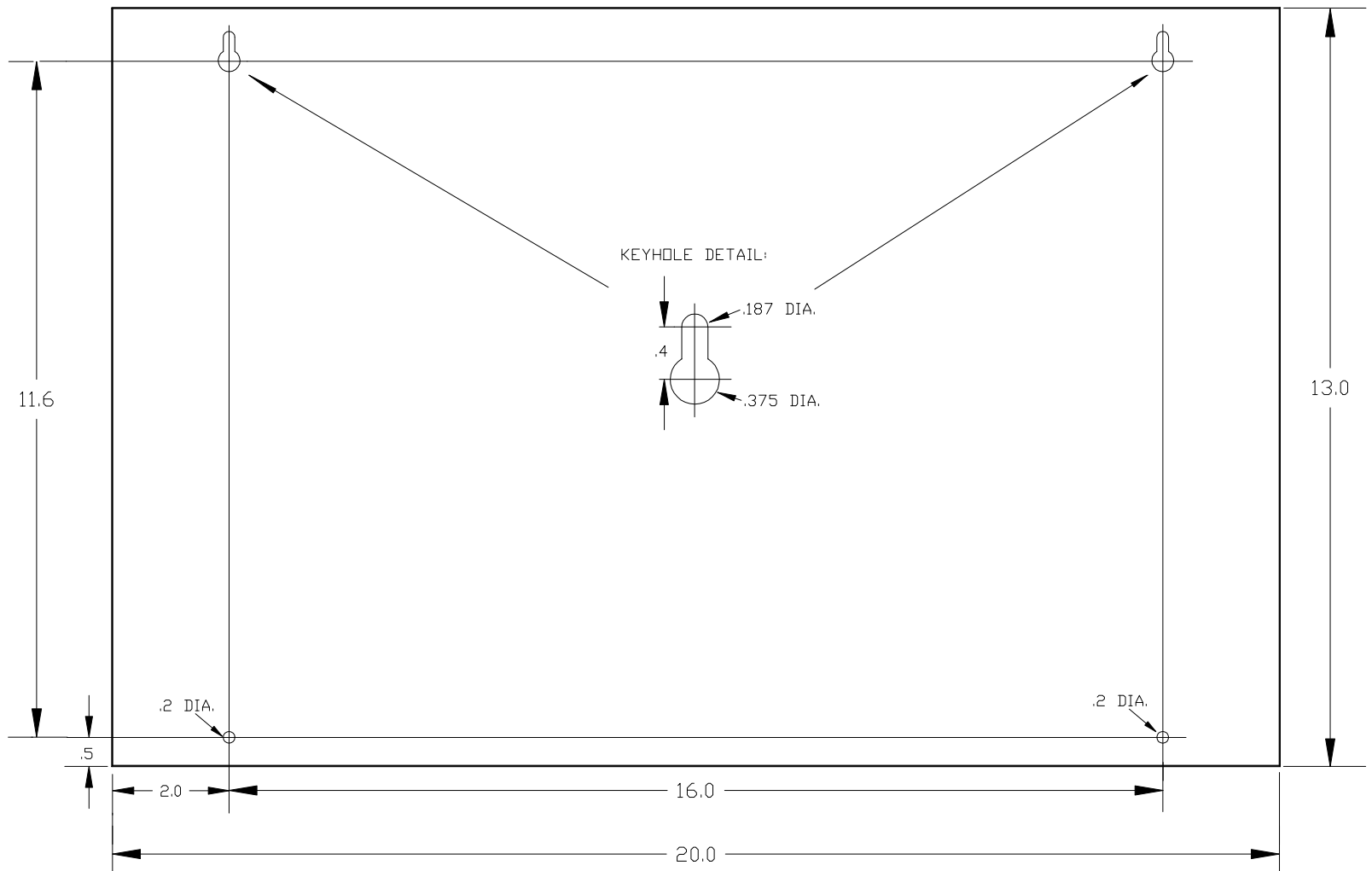

NOTE:
ALL DIMENSIONS IN INCHES

TITLE		MLS-EC1 ENCLOSURE MOUNTING HOLE DIMENSIONS	
NUMBER	C022397-2	REVISION	ORIG. SIZE A
DATE: 2/23/97		SHEET	1 OF 1
FILE: EC1-MNT		DRAWN BY:	MG

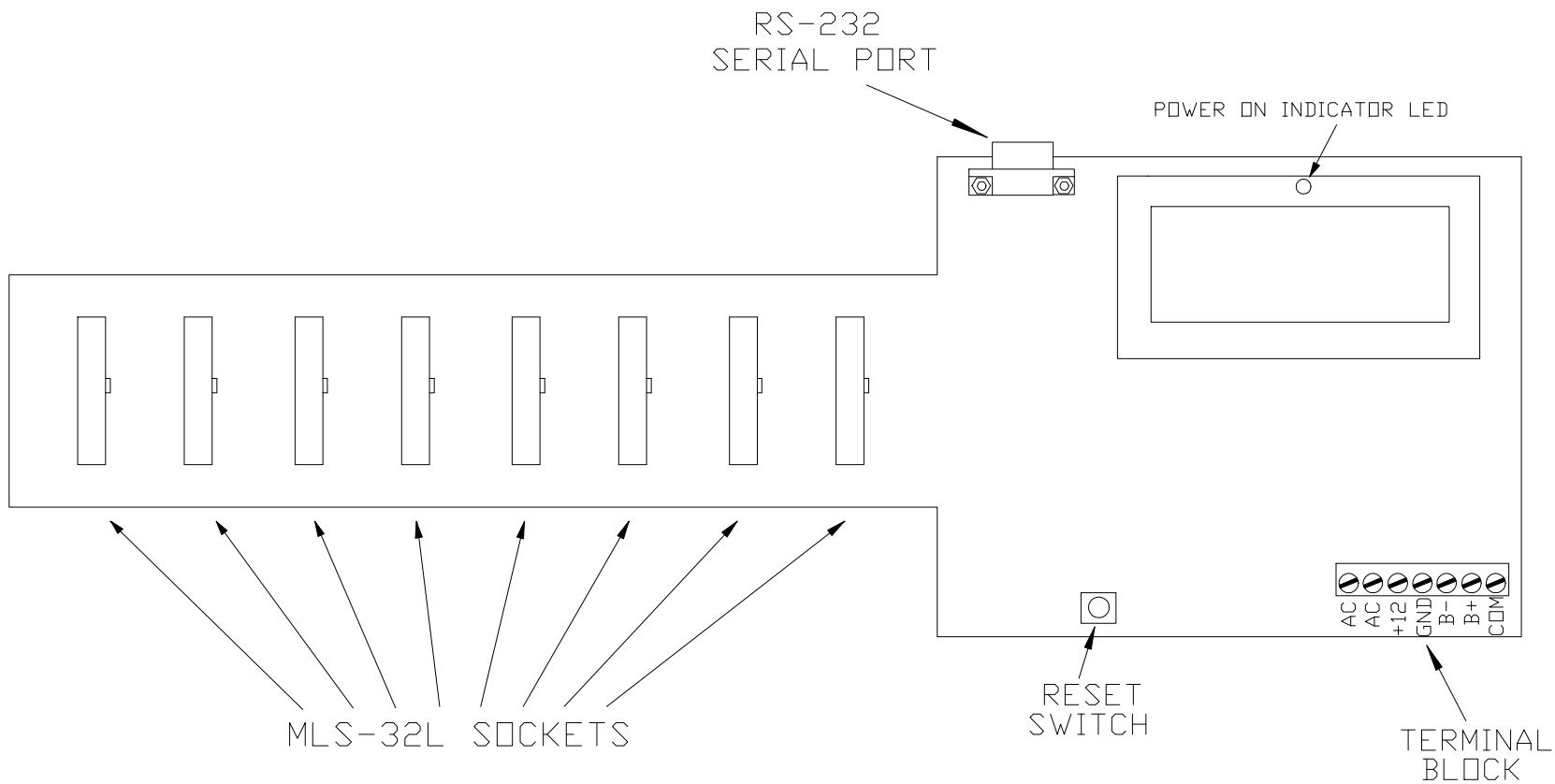

TITLE		MLS-SPU1 SIGNAL PROCESSING UNIT	
NUMBER	C082002-1	REVISION	
DATE: 8/20/02	SHEET 1 OF 1	ORIG. SIZE	A
FILE: SPU1OVER	DRAWN BY: MG		

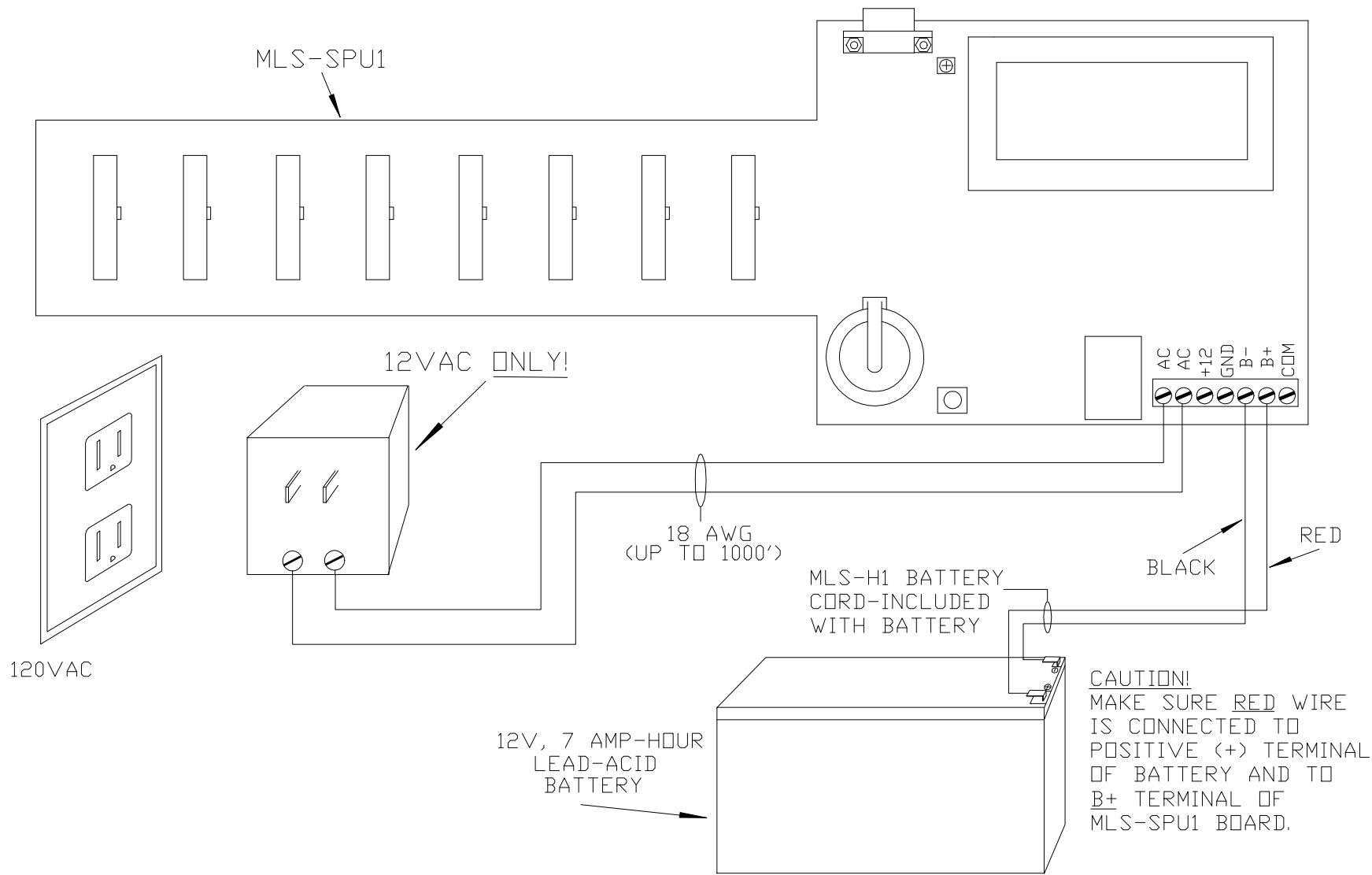

TITLE	
POWER WIRING AND POWER BACK-UP BATTERY CONNECTIONS TO MLS-SPU1	
NUMBER	C022397-5
DATE: 2/23/97	SHEET 1 OF 1
FILE: PWR-BATT	DRAWN BY: MG
REVISION	ORIG. SIZE A

MLS-32L

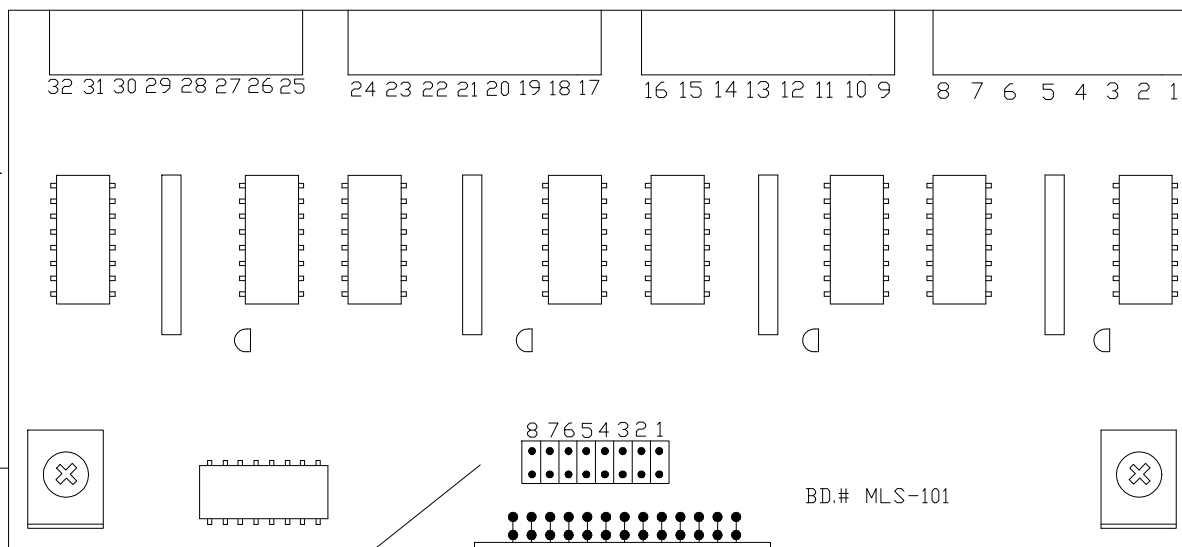

PROGRAMMING JUMPER

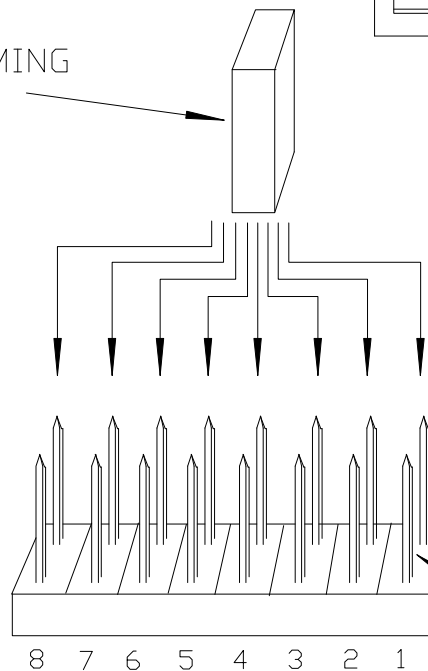

PLACE PROGRAMMING JUMPER OVER STAKE-PIN PAIR 1-8 TO PROGRAM A MLS-32L INPUT BOARD.

FOR EXAMPLE, PLACING THE PROGRAMMING JUMPER OVER THE STAKE-PINS ON THE FAR RIGHT WILL PROGRAM THIS MLS-32L BOARD AS INPUT BOARD #1 (INPUTS 1-32).

STAKE-PINS (PAIR #1)

TITLE		PROGRAMMING THE MLS-32L	
NUMBER	C022397-3	REVISION	ORIG. SIZE A
DATE: 2/23/97	SHEET	1 OF 1	
FILE: 32L-PRDG	DRAWN BY:	MG	

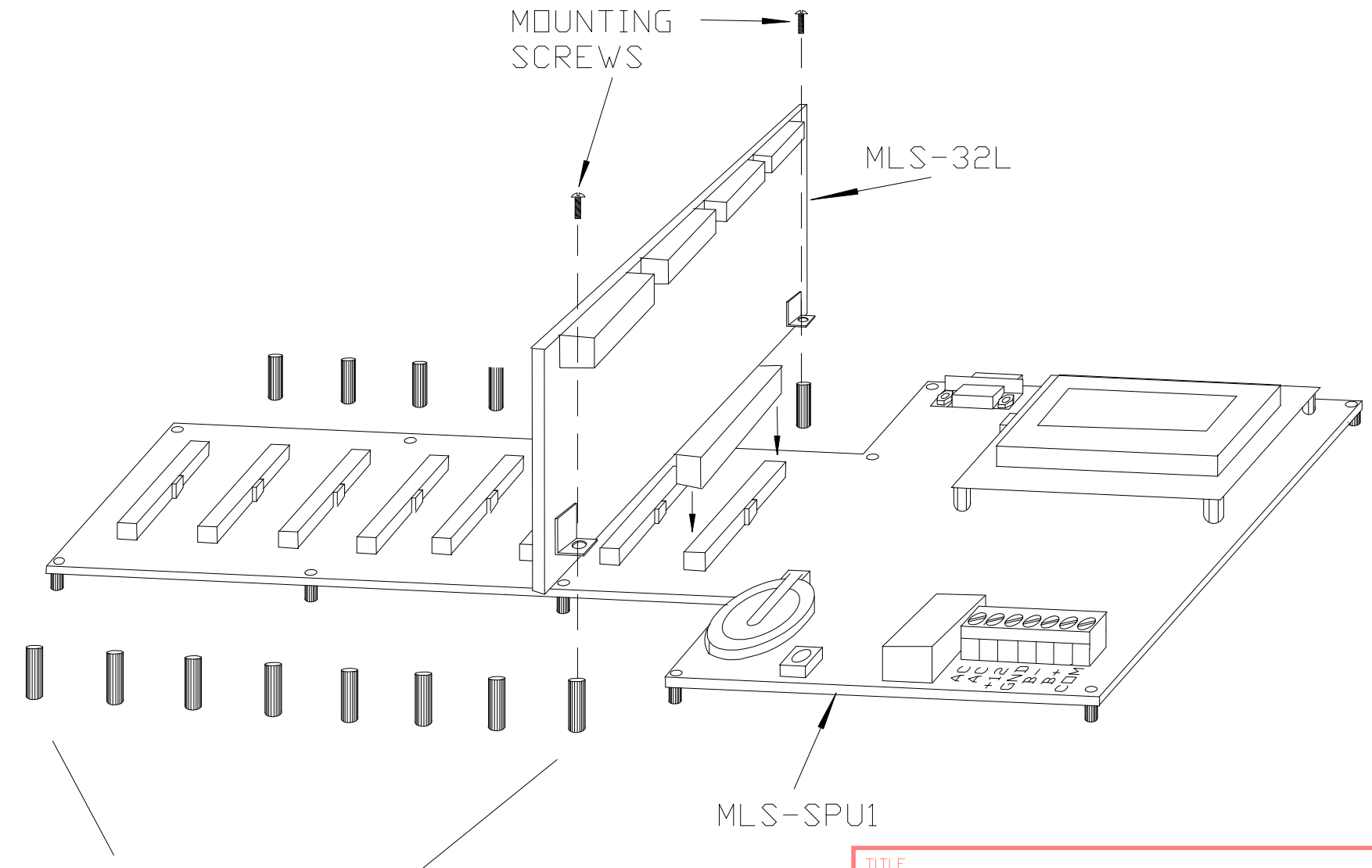

MOUNTING
SCREWS

MLS-32L

MLS-SPU1

MLS-32L MOUNTING SPACER/NUTS

TITLE		INSTALLING MLS-32L BOARD	
NUMBER	C030297-1	REVISION	ORIG. SIZE A
DATE: 3/2/97		SHEET	1 OF 1
FILE: INST-IBD		DRAWN BY:	MG

18-24 AWG SIGNAL WIRE

INSERT WIRE IN TERMINAL
BLOCK-TIGHTEN SCREW

PLUGGABLE TERMINAL BLOCK

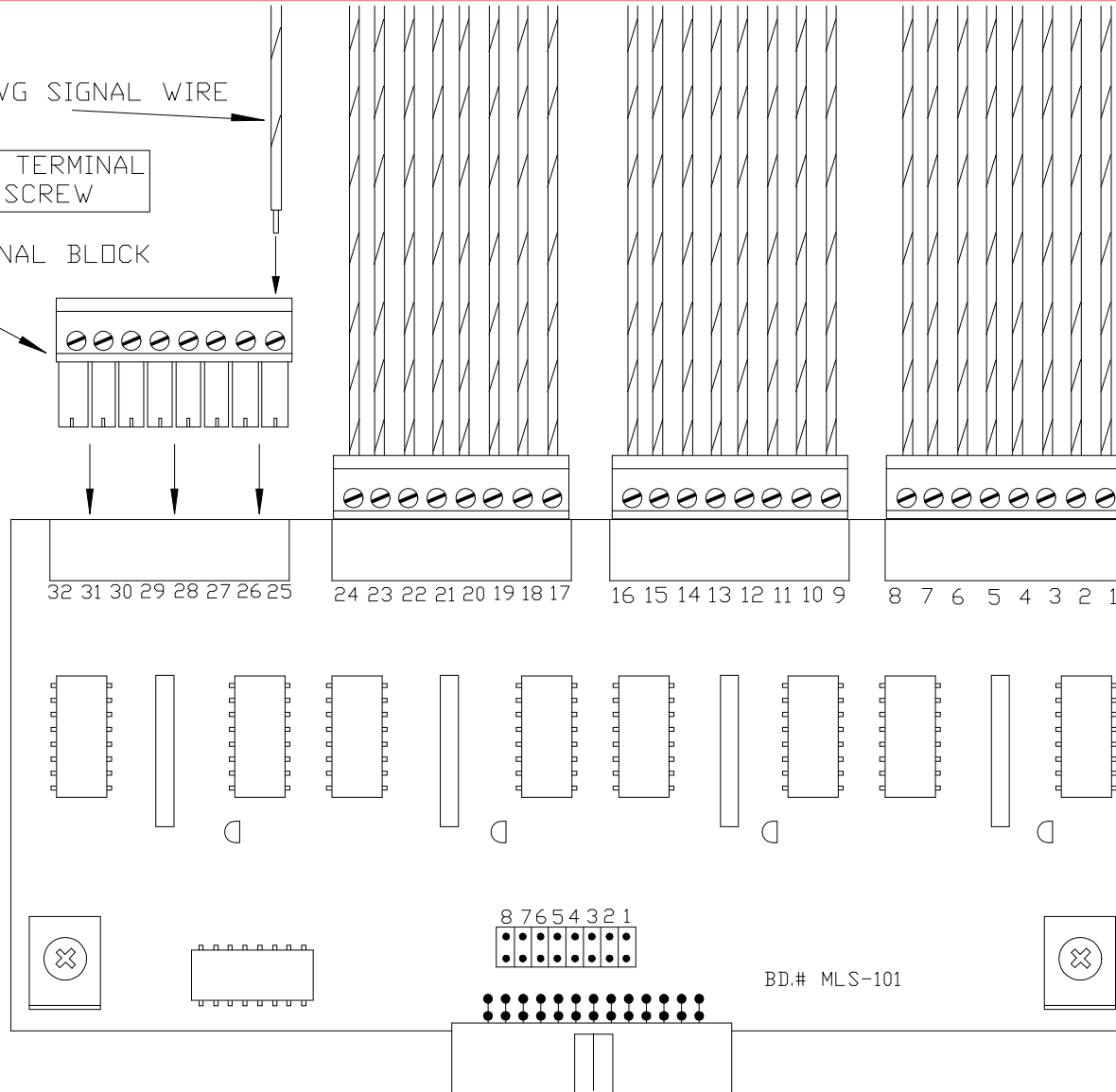

TITLE	
CONNECTING CALL/ALARM SIGNAL WIRE TO MLS-32L	
NUMBER	REVISION
C030497-1	ORIG. SIZE A
DATE: 3/4/97	SHEET 1 OF 1
FILE: 32L-WIRE	DRAWN BY: MG

NORMALLY OPEN CONTACTS
BEING MONITORED

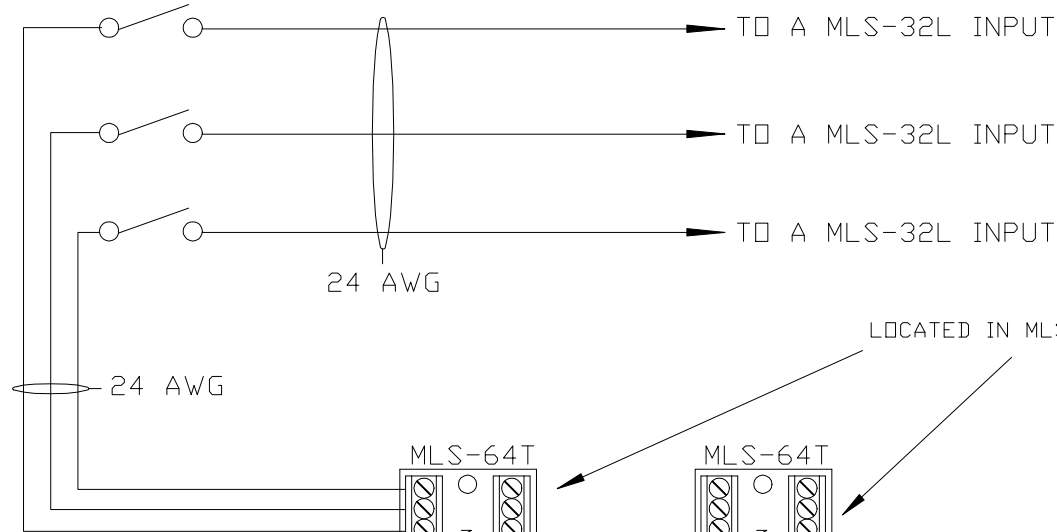

MLS-SPU1 BOARD

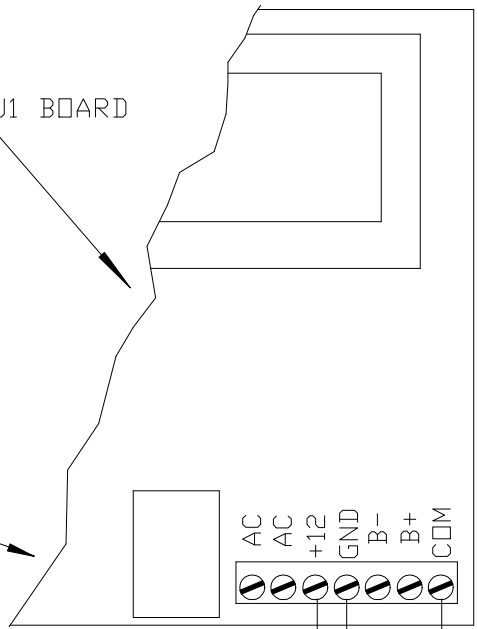

LOCATED IN MLS-EC1 ENCLOSURE

THESE WIRES MAY BE
CONNECTED TO ANY
TERMINAL (ON ANY
MLS-64T BOARD, IF
THERE ARE MORE THAN 1
MLS-64T BOARDS), IN
ANY ORDER.

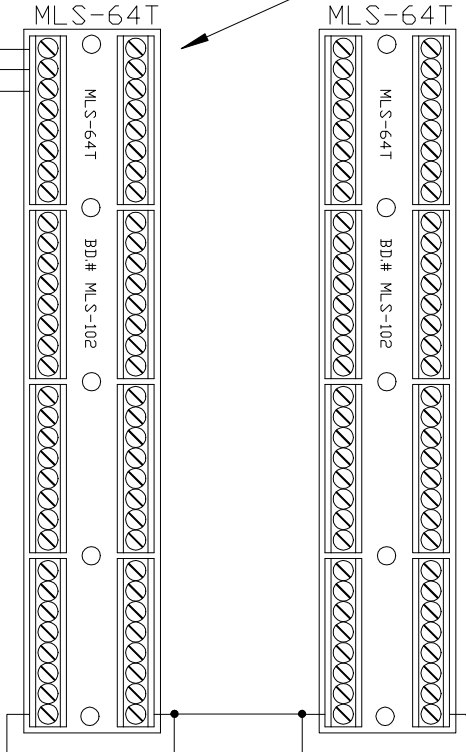

NOTE:
MLS-64T BOARDS ARE OPTIONAL. THEY
PROVIDE CONVENIENT TERMINATION
OF ONE WIRE FROM EACH PAIR AND
ELECTRICALLY CONNECT THEM TO A
COMMON VOLTAGE.

JUMPER
WIRE

24 AWG

TITLE N.D. ALARM/FAULT CONTACT WIRING TO ALPHA-PAGE	
NUMBER C030797-1	REVISION ORIG. SIZE A
DATE: 3/7/97	SHEET 1 OF 1
FILE: DRY-ND	DRAWN BY: MG

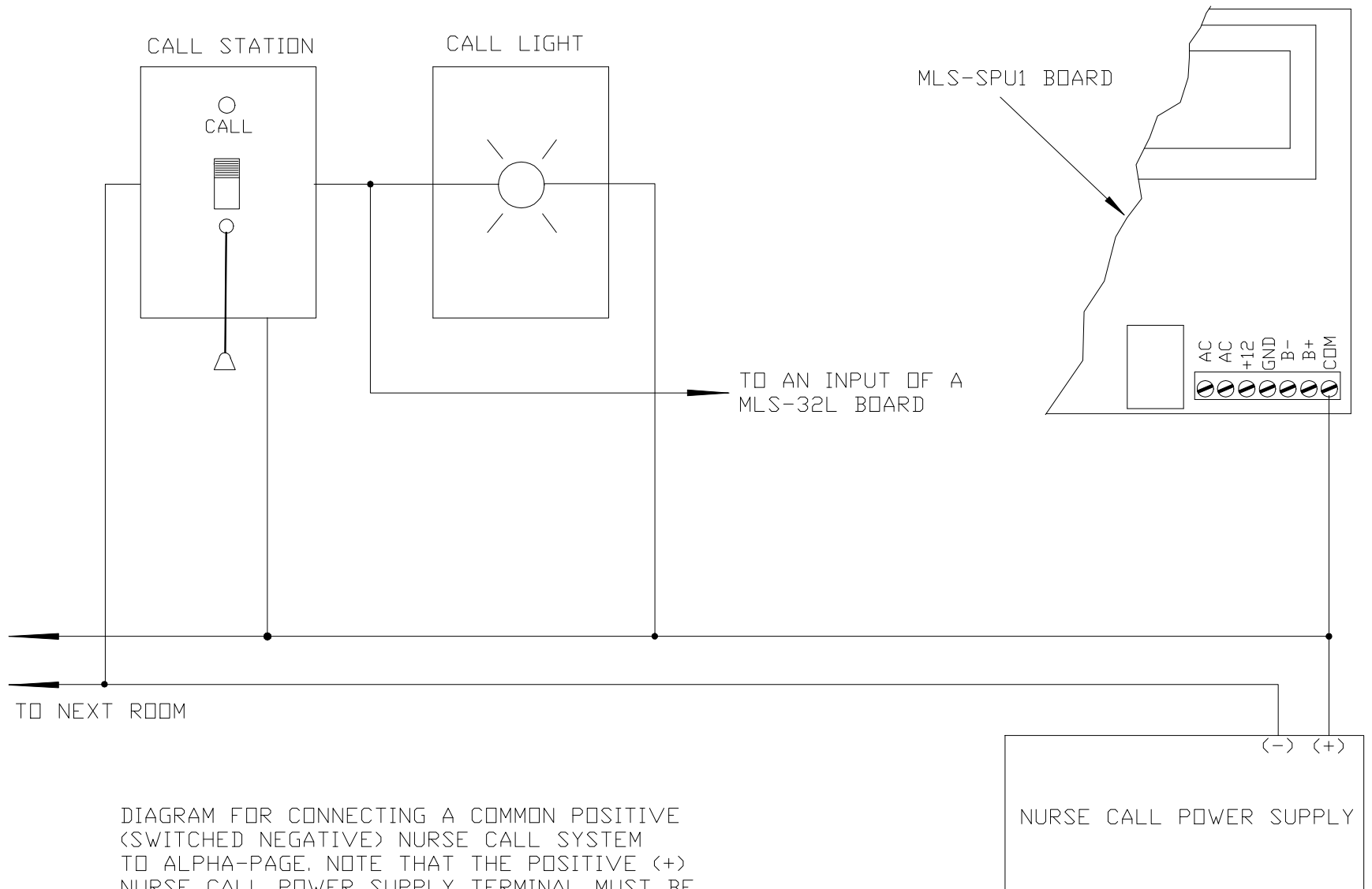

DIAGRAM FOR CONNECTING A COMMON POSITIVE (SWITCHED NEGATIVE) NURSE CALL SYSTEM TO ALPHA-PAGE. NOTE THAT THE POSITIVE (+) NURSE CALL POWER SUPPLY TERMINAL MUST BE CONNECTED TO THE "COM" TERMINAL OF THE MLS-SPU1 BOARD.

TITLE		CONNECTING COMMON PLUS NURSE CALL SYSTEM TO ALPHA-PAGE	
NUMBER	C030397-1	REVISION	A
DATE: 3/3/97	REV. 4/9/98	ORIG. SIZE	A
FILE: NC-COM-P	SHEET	1	OF 1
		DRAWN BY:	MG

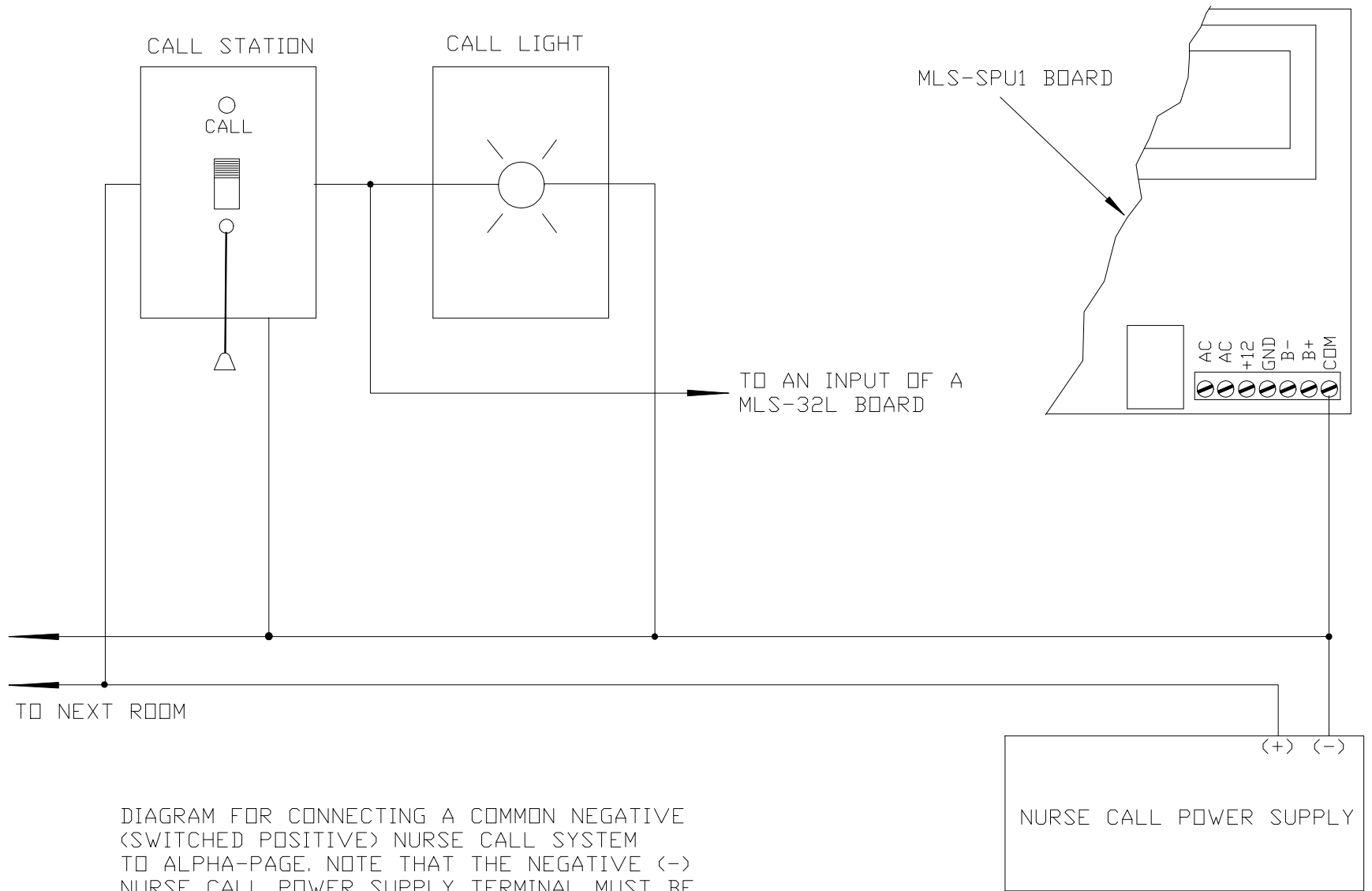
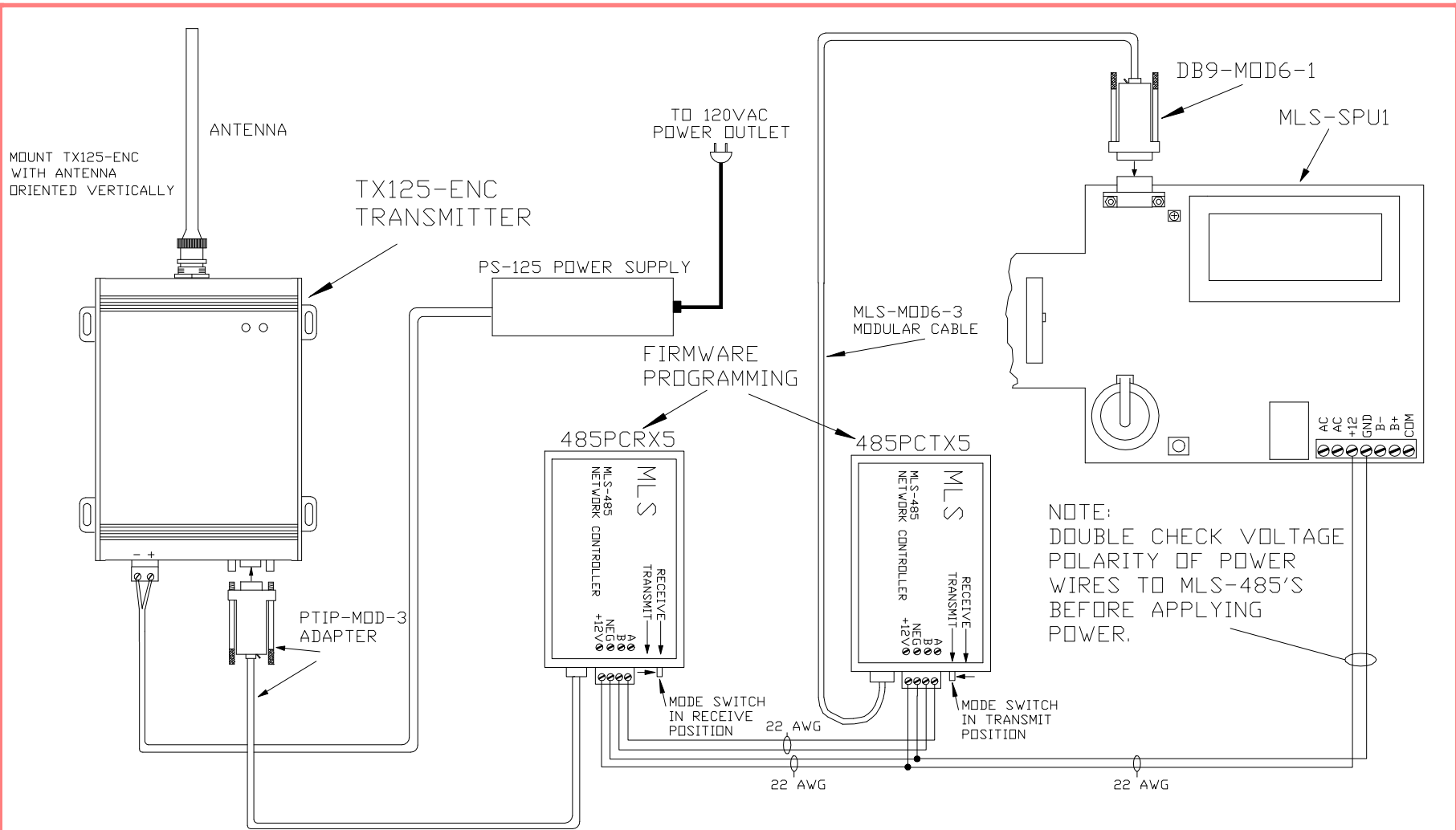

DIAGRAM FOR CONNECTING A COMMON NEGATIVE (SWITCHED POSITIVE) NURSE CALL SYSTEM TO ALPHA-PAGE. NOTE THAT THE NEGATIVE (-) NURSE CALL POWER SUPPLY TERMINAL MUST BE CONNECTED TO THE "COM" TERMINAL OF THE MLS-SPU1 BOARD.

TITLE	
CONNECTING COMMON NEGATIVE NURSE CALL SYSTEM TO ALPHA-PAGE	
NUMBER	REVISION
C030397-2	A
DATE: 3/3/97 REV. 4/9/98	ORIG. SIZE
	A
FILE: NC-COM-N	SHEET 1 OF 1
	DRAWN BY: MG



NOTES:
 THE TX125-ENC TRANSMITTER CAN BE LOCATED REMOTELY FROM THE MLS-SPU1 PROCESSOR BOARD, MLS-485'S FUNCTION AS SHORT HAUL MODEMS. THE MLS-485'S (AND THEREFORE THE MLS-SPU1 AND TX125-ENC MAY BE SEPARATED BY UP TO 2500'.

THE MLS-485'S ARE NOT INTERCHANGEABLE, THEY HAVE DIFFERENT FIRMWARE PROGRAMMING (485PCT5 & 485PCR5). THE FIRMWARE INSTALLED IN EACH IS INDICATED ON A LABEL ON THE BOTTOM OF EACH MLS-485. THIS DRAWING SHOWS THE PROPER LOCATION FOR EACH.

TITLE		CONNECTING TX125-ENC TO ALPHA-PAGE	
NUMBER	C091905-1	REVISION	
DATE: 9/19/05	SHEET	1	OF 1
FILE: AP-125	DRAWN BY:	MG	

WARRANTY

ELEMENTS OF LIMITED WARRANTY: Alpha Communications® warrants, for one year, this Alpha-Page product to be free from defects in materials and workmanship with only the limitations or exclusions set out below.

This warranty shall terminate one year after the date of original sale. The warranty is invalid if the product is modified, altered, improperly installed, or repaired by parties other than Alpha Communications®. Power transformers with blown fuses are excluded from this warranty. Care must be taken to avoid short circuiting the secondary terminals of power transformers.

THE LIMITED WARRANTY SET FORTH ABOVE IS THE SOLE AND ENTIRE WARRANTY PERTAINING TO THE PRODUCT AND IS IN LIEU OF AND EXCLUDES ALL OTHER WARRANTIES OF ANY NATURE WHATSOEVER, WHETHER EXPRESS, IMPLIED OR ARISING BY OPERATION OF LAW, INCLUDING, BUT NOT LIMITED TO ANY IMPLIED WARRANTIES OF MERCHANTABILITY OR FITNESS FOR A PARTICULAR PURPOSE. THIS WARRANTY DOES NOT COVER OR PROVIDE FOR THE REIMBURSEMENT OR PAYMENT OF INCIDENTAL OR CONSEQUENTIAL DAMAGES. Some states do not allow this exclusion or limitation of incidental or consequential damages so the above limitation or exclusion may not apply.

STATEMENT OF REMEDY: In the event that the product does not conform to this warranty at any time this warranty is in effect, Alpha Communications® will repair the defect and return it to you without charge for parts, service, or any other cost incurred by Alpha Communications®. Customer is responsible for shipping costs for returning defective product. Alpha Communications® is responsible for return shipping costs associated with returning the repaired product to the customer. Product will be returned by the same means it was received (ground, 2nd day air, overnight). Customer must call Alpha Communications® Systems and obtain authorization before returning equipment.

Return shipping expense of equipment that is determined by Alpha Communications® to NOT be defective will be billed to the customer. There is no charge for testing equipment even if the equipment proves to be functioning properly.

PAGER LIMITED WARRANTY

Pocket pagers sold by Alpha Communications® are covered only by the warranty extended by the pager manufacturer. Call Alpha Communications® for assistance on pocket pager repair.