



*Communications  
for today... and tomorrow*

IL381  
SECTION E  
Rev. 17 - 03/2011

**Tek-CARE® NC110A, NC110N  
Visual Nurse Call Signaling System**  
UL® 1069 Listed

**Operation, Installation and Service Manual**



**Alpha Communications®**  
42 Central Drive  
Farmingdale, NY 11735-1202  
Phone: (631) 777-5500  
Fax: (631) 777-5599

Website:  
[www.AlphaCommunications.com](http://www.AlphaCommunications.com)

Email:  
[info@alphacommunications.com](mailto:info@alphacommunications.com)

TOLL-FREE Technical #:  
**1-800-666-4800**

**APPLICATION:** The Tek-CARE® NC110A, NC110N Visual Nurse Call Signaling System is designed for nursing home or individual ward use. The nurse call system provides audible and visual indication of all calls originating in the system, including both normal and emergency calls. The NC110A, NC110N Master Station contains lamps for call indication, as well as tone-off switch and an audible tone signaling device.

## **Operation, Installation and Service Manual**

*Copyright © 2001–2011*

*TekTone® Sound & Signal Mfg., Inc., All rights reserved.*

No part of this publication may be copied without the express written permission of TekTone® Sound & Signal Mfg., Inc. The content of this manual is furnished for informational use only, is subject to change without notice, and should not be construed as a commitment by TekTone® Sound & Signal Mfg., Inc. TekTone® Sound & Signal Mfg., Inc. assumes no responsibility or liability for any errors or inaccuracies that may appear in this documentation.

TekTone, the TekTone logo, Tek-Call, Tek-Care, Tek-Check-In, Tek-Com, Tek-Digicare, Tek-Door, Tek-Entry III, Tek-Guard, Tek-Micro, Tek-Micro II, Tek-MMARS II, TekNIOS, TekNIOS II, Tek-Paging, Tek-Phone, Tek-Safe, Tek-Select II, Tek-Sentry, Tek-Sound, Tek-Status, Tek-Trio and Tek-View are either registered trademarks or trademarks of TekTone® Sound & Signal Mfg., Inc. in the United States and/or other countries. All other trademarks are the property of their respective owners.

# Table of Contents

---

|  |           |
|--|-----------|
| <b>System Operating Instructions</b> .....                                     | <b>1</b>  |
| NC110N Master Stations .....   | 1         |
| NC110A Master Stations .....   | 3         |
| SF100N, SF100/2, SF100C, SF102 Call Stations .....                             | 3         |
| SF101N, SF101C Call Stations .....   | 3         |
| SF151N, SF153N, SF155B, SF339 Emergency Stations and SF156B Code Station ..... | 4         |
| LI150N, LI150B Duty Stations .....   | 5         |
| LI381 Corridor Lights .....  | 5         |
| LI382, LI382LED Corridor Zone Lights .....                                     | 5         |
| <br>   |           |
| <b>System Operating Principle</b> .....  | <b>6</b>  |
| PK151A, PK152 Power & Control Units .....                                      | 6         |
| PK800A Secondary Power Supply .....  | 6         |
| NC110N Master Stations .....   | 6         |
| NC110A Master Stations .....   | 6         |
| SF100N, SF100/2, SF100C, SF101B, SF101N, SF101C, SF102 Call Stations .....     | 7         |
| SF151N, SF153N, SF155B, SF339 Emergency Stations and SF156B Code Station ..... | 7         |
| <br>   |           |
| <b>System Installation</b> .....   | <b>8</b>  |
| Installation Procedure .....   | 8         |
| Equipment Locations .....  | 8         |
| Wiring Installation .....  | 9         |
| Housing Installation .....   | 9         |
| Wire Checkout .....  | 11        |
| Wire Connections .....   | 11        |
| Connections Checkout .....   | 12        |
| System Test Instructions .....   | 12        |
| System Checkout and Testing .....  | 12        |
| <br>   |           |
| <b>System Maintenance Instructions</b> .....                                   | <b>14</b> |
| NC110A Master Stations .....   | 14        |
| NC110N Master Stations .....   | 14        |
| PK151A, PK152 Power & Control Units .....                                      | 15        |
| PK153 Third Priority Control Unit .....  | 15        |
| PK800A Secondary Power Supply .....  | 15        |
| FZ151 In-Line Fuse Holder .....  | 15        |
| SF100N, SF100/2, SF100C, SF102 Call Stations .....                             | 15        |
| SF101N, SF101C Call Stations .....   | 16        |
| SF151N, SF153N, SF155B, SF339 Emergency Stations and SF156B Code Station ..... | 16        |
| LI150N, LI150B Duty Stations .....   | 16        |
| LI381 Corridor and LI382 Corridor Zone Lights .....                            | 16        |
| Replacement Parts .....  | 16        |

**Illustrations**

Figure 1—NC110N Master Station Control Locations ..... 1

Figure 2—NC110A Master Station Control Locations ..... 2

Figure 3—Call Station and Call Cord Control Locations ..... 2

Figure 4—Emergency, Code, Call & Duty Station Control Locations ..... 4

Figure 5—Master Panel Housing Chart and Wall Cut-Out Details ..... 10

Figure 6—Ring & Back Box for Call, Emergency, Code & Duty Stations,  
and Corridor & Zone Lights ..... 10

Figure 7—SS106 Transformer Installation ..... 10

Figure 8—NC110N Selector Lamp/Switch Lens, Filter and Lamp Replacement ..... 14

Figure 9—NC110A Wiring Diagram ..... 17

Figure 10—NC110N Wiring Diagram ..... 18

Figure 10a—NC150N, NC200N, Two Stations in Parallel ..... 19

Figure 11—NC110A Housing Installation Diagram ..... 20

Figure 12—PL116 Wall Plate Wiring Diagram ..... 20

Figure 13—NC110N Second Master Wiring Diagram ..... 21

Figure 14—PK153 Wiring Diagram ..... 22

Figure 15—PK153 Wiring Diagram with SF156B Code Station ..... 23

Figure 16—PK151A or PK152 to PK800A Interconnection ..... 24

Figure 17—SF337C Cross Reference Diagram ..... 25

Figure 18—SF339 Cross Reference Diagram ..... 26

Figure 19—NC110N Hookup to NC150N, NC200N ..... 27

Figure 20—SF157 and SF157/2 Wiring Diagram ..... 28

# System Operating Instructions

This section provides complete operating instruction for all Tek-CARE® NC110N and NC110A functions, as well as reference drawings for use in locating and describing all controls. System operators must read the following operating instructions concerning system equipment and the terms used in conjunction with the equipment.

## NC110N Master Stations

Refer to *Figure 1* for locations, names, and functions of controls and indicators.

### **Answer Emergency Calls:**

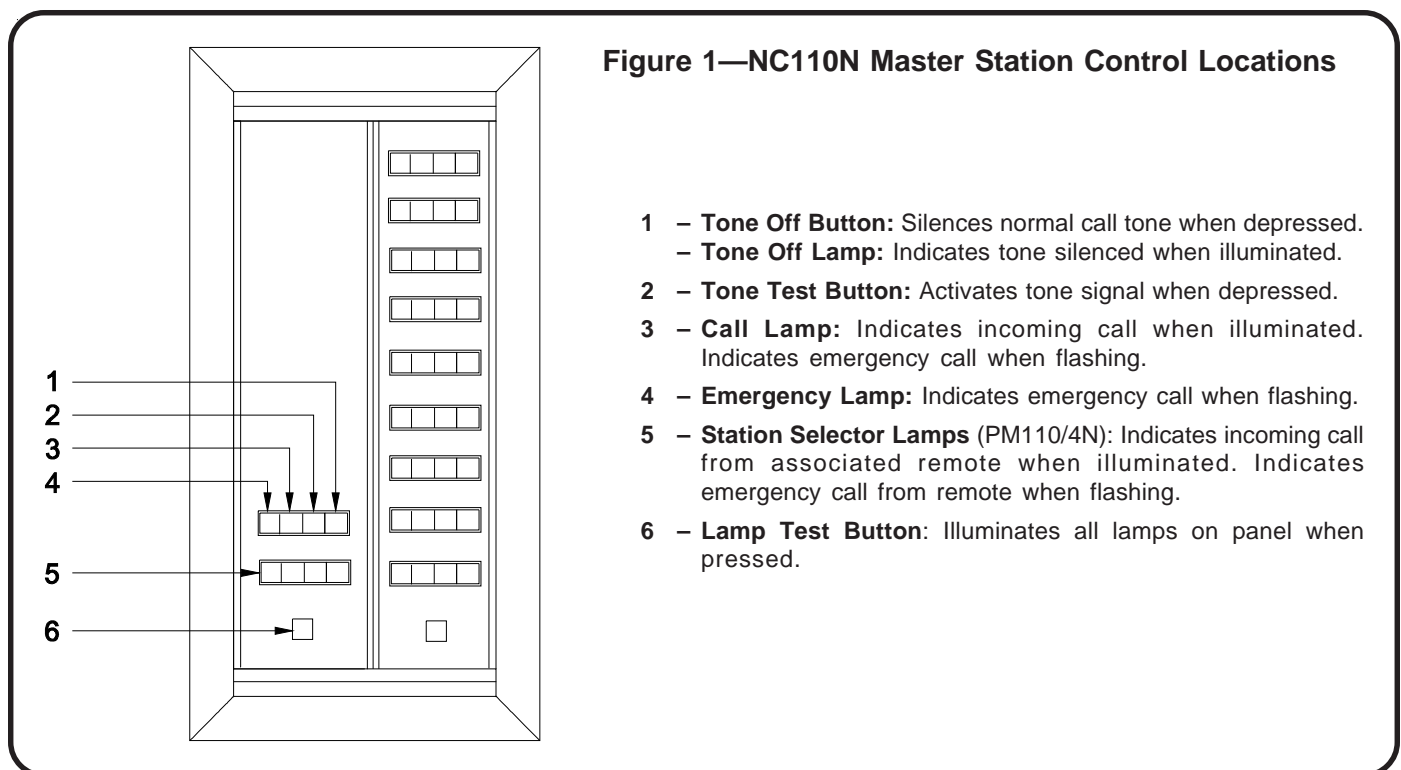
All emergency calls take precedence over any normal call signal. Calls must be answered in person and can only be canceled from point of origin. Emergency calls are indicated by simultaneous operation of the following signals:

- Rapid flashing of the associated station selector lamp, which is marked to indicate origin of call.
- Rapid flashing of call lamp and emergency lamp.
- Rapidly pulsing audible tone.

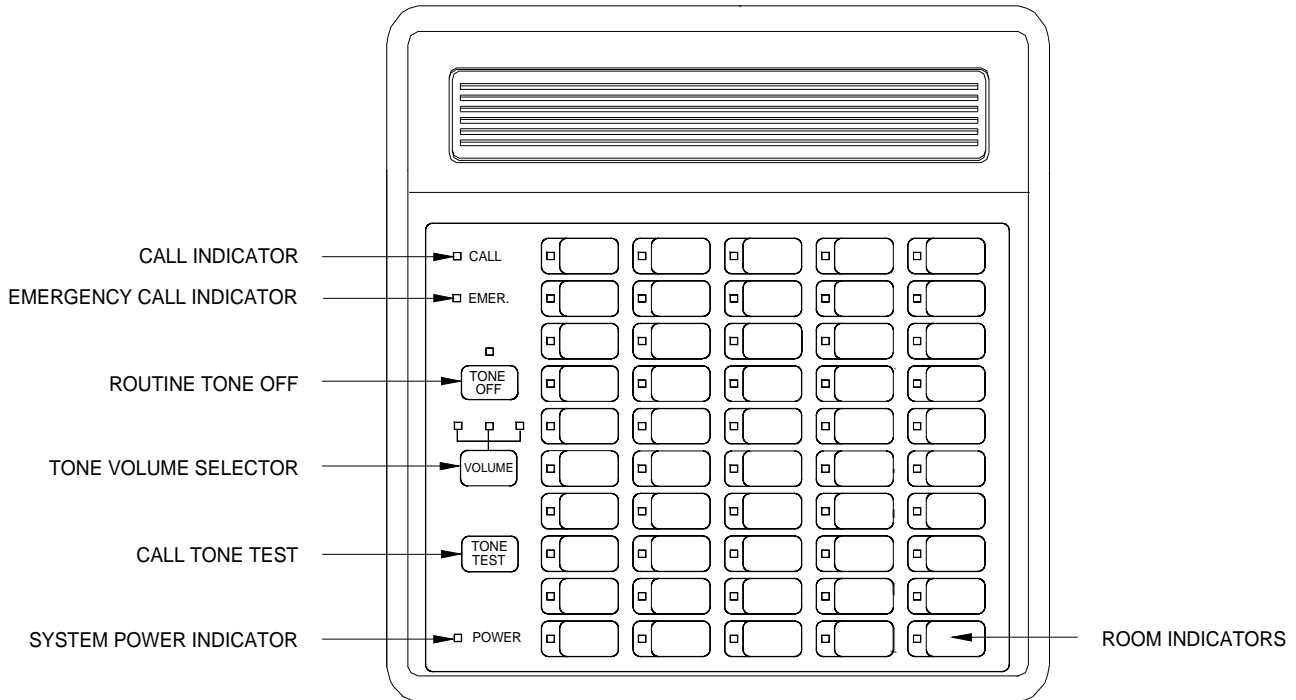
### **Answer Normal Calls:**

Calls must be answered in person and can only be canceled from point of origin. Normal calls are indicated by simultaneous operation of the following signals:

- Steady illumination of the associated station selector lamp which is marked to indicate origin of call.
- Steady illumination of call lamp.
- Slowly pulsing audible tone. The audible call signal may be canceled for normal calls by pressing the **TONE OFF** button. The **TONE OFF** button will then illuminate to indicate tone silenced. Pressing the **TONE OFF** button when illuminated will reset the call tone.

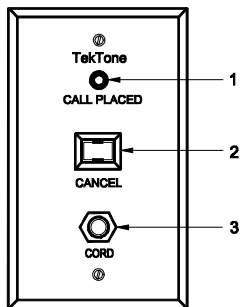


**Figure 2—NC110A Master Station Control Locations**

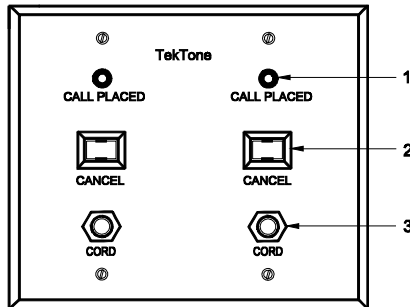


**Figure 3—Call Station and Call Cord Control Locations**

**SF100N Call Station**

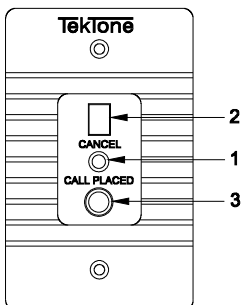


**SF100/2 Dual Call Station**

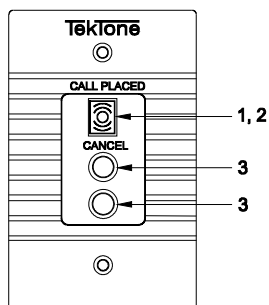


- 1 – **Call Placed Lamp:** Indicates a call is placed when flashing.
- 2 – **Cancel Button:** Cancels the call when pressed.
- 3 – **Call Cord Jack:** Receptacle for SF301A or SF302 call cord.
- 4 – **Plug:** Connects call cord to patient station when plugged into call cord jack.
- 5 – **Call Button:** Places a call when pressed, if cord is connected to patient station.

**SF100C Call Station**



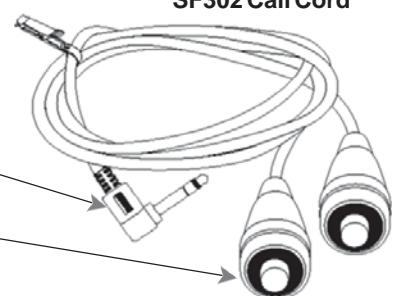
**SF102 Dual Call Station**



**SF301A Call Cord**



**SF302 Call Cord**



### ***Test Tone Signal:***

Press the **TONE TEST** button. A tone signal should be heard at the master station.

### ***Test Station Selector Lamps:***

Press the **LAMP TEST** button (one is included for each panel of annunciator lamps). All annunciator lamps on that panel should be illuminated. (See *System Maintenance Instructions* for proper procedures and precautions in replacing defective lamps.)

### ***Improper Operation:***

- If the NC110N Master Station fails to operate as described, contact qualified service personnel. There are no user replaceable parts on the NC110N Master Station other than the station selector lamps and lenses.
- If a malfunction occurs during a call and causes a lack of indication of call origin on the master station, first determine the origin of the call by observing which corridor light and corridor zone light is illuminated, then inform qualified service personnel.

## NC110A Master Stations

Refer to *Figure 2* for locations, names, and functions of controls and indicators. Operation of the NC110A is similar to that of the NC110N, except that there is no selector lamp test (NC110A has selector LEDs instead).

### ***Adjust volume:***

The NC110A master station has three volume levels. Press the volume button until the desired level is reached. The level is indicated by three lighted LEDs above the volume button. Use the tone test button to test volume when adjusting the volume.

### ***Selector point labeling:***

A slot is provided at the top of each column of selector points for inserting a paper strip (TekTone® part number LB516). Apply room-identifying labels between the dashed lines so that each label lines up with the intended selector point on the NC110A membrane switch.

## SF100N, SF100/2, SF100C, SF102 Call Stations

Refer to *Figure 3* for locations, names, and functions of controls and indicators.

***Call a Nurse:*** Press the **CALL** button located on the end of the call cord. The **CALL PLACED** lamp will illuminate to indicate call placement. Wait for the nurse. Refer to *Figure 3* for locations, names, and functions of call cord controls.

***Cancel a Call:*** Press the **CANCEL** button. Indicator will go off. If the call cord is pulled from its receptacle, a call will be placed automatically and cannot be canceled until the call cord is replaced in the receptacle.

***Replace Call Cord:*** See *System Maintenance Instructions* for proper procedures and precautions in replacing defective call cords.

***Improper Operation:*** If the call station does not operate as described, contact qualified service personnel. There are no user serviceable parts on the SF100N, SF100/2, SF100C and SF102 Call Stations other than cords.

## SF101N, SF101C Call Stations

Refer to *Figure 4* for locations, names, and functions of controls and indicators.

***Call a Nurse:*** Press the **CALL** button. The **CALL PLACED** lamp will illuminate to indicate call placement. Wait for the nurse.

**Cancel a Call:** Press cancel button. Indicator will turn off.

**Improper Operation:** If the call station does not operate as described, contact qualified service personnel. There are no user serviceable parts on the SF101N and SF101C Call Stations.

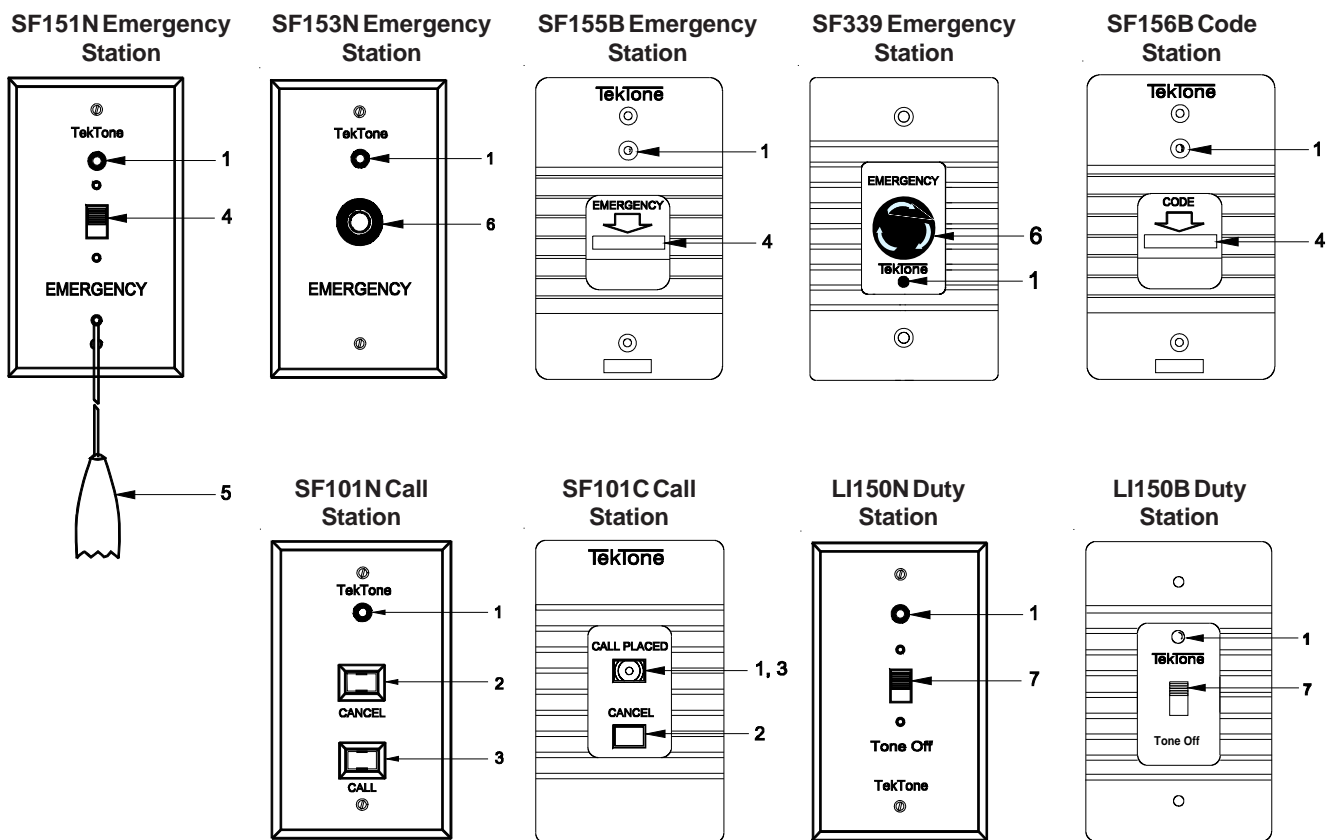
**SF151N, SF153N, SF155B, SF339 Emergency Stations and SF156B Code Station**

Refer to *Figure 4* for locations, names, and functions of controls and indicators.

**Call a Nurse:** Pull the call cord, slide the call/cancel switch down, or press the call/cancel button. The CALL PLACED lamp will flash. Wait for the nurse.

**Cancel a Call:** Push the call/cancel switch up, press the call/cancel button, or twist the push button. The CALL PLACED lamp will go off.

**Figure 4—Emergency, Code, Call & Duty Station Control Locations**



- 1 – **Call Placed Lamp:** Indicates a call is placed when flashing.
- 2 – **Cancel Button:** Cancels the call when pressed.
- 3 – **Call Button:** Places a call when pressed.
- 4 – **Call/Cancel Switch:** Places a call when pulled down. Cancels the call when pushed up.
- 5 – **Call Cord:** Places a call when pulled.
- 6 – **Call/Cancel Button:** Places a call when pressed to *in* position. Cancels the call when pressed or twisted to *out* position.
- 7 – **Tone Off Switch:** Silences normal audible tone signal when pushed down.



**Improper Operation:** If the call station does not operate as described, contact qualified service personnel. There are no user serviceable parts on the SF151N, SF153N, SF155B, SF339 Emergency Stations or the SF156B Code Station.

### LI150N, LI150B Duty Stations

Refer to *Figure 4* for locations, names, and functions of controls and indicators.

**Emergency Calls:** Emergency calls are indicated by a flashing CALL PLACED lamp and a rapidly pulsing audible tone. The audible tone signal cannot be silenced by the TONE OFF switch.

**Normal Calls:** Normal calls are indicated by steady illumination of the CALL PLACED lamp and a slowly pulsing audible tone. Push the TONE OFF switch down to silence the audible tone signal. Push the TONE OFF switch up to turn the audible tone signal on.

**Improper Operation:** If the call station does not operate as described, contact qualified service personnel. There are no user serviceable parts on the LI150N and LI150B Duty Stations.

### LI381 Corridor Lights

**Emergency Calls:** Emergency calls are indicated by rapid flashing of the corridor light that is associated with the calling station.

**Normal Calls:** Normal calls are indicated by steady illumination of the corridor light that is associated with the calling station.

**Lamp Replacement:** See *System Maintenance Instructions* for proper procedures and precautions in replacing defective lamps.

**Improper Operation:** If corridor light does not operate as described, contact qualified service personnel. There are no user serviceable parts on the LI381 Corridor Lights other than lamps.

### LI382, LI382LED Corridor Zone Lights

The LI382 Corridor Zone Light includes two indicator lamps: a clear normal call indicator lamp and an emergency call indicator lamp with a red bulb cover. The LI382LED Corridor Zone Light includes four indicator LEDs: two clear normal call indicator LEDs that operate in unison, and two red emergency call indicator LEDs that operate in unison.

**Emergency Calls:** Emergency calls are indicated by rapid flashing of the red corridor zone light(s) associated with the zone or area from which an emergency call has been placed.

**Normal Calls:** Normal calls are indicated by steady illumination of the white corridor zone light(s) associated with the zone or area from which a normal call has been placed.

**Concurrent Emergency and Normal Calls:** If an emergency and normal call are placed in the same zone at the same time, the red light(s) connected to the emergency station from which a call was placed will flash rapidly, while the white light(s) associated with the normal call will maintain a steady illumination.

**Lamp Replacement:** See *System Maintenance Instructions* for proper procedures and precautions in replacing defective LI382 lamps.

**Improper Operation:** If corridor zone light does not operate as described, contact qualified service personnel. There are no user serviceable parts on the LI382 Corridor Zone Lights other than lamps and red bulb cover. There are no user serviceable parts on the LI382LED Corridor Zone Lights.

# System Operating Principle

---

Each system uses a series of bus conductors to carry the operating and signaling voltage to the various units. In addition, each station capable of calling the master station has individual conductors between it and the master to give the station its own identity.

When a call button is depressed, switching circuits operate to light various call lights and to energize system call tone. All calls must be reset at the point of origin.

Emergency calls are signaled by a different flashing rate at the master station. An emergency call is indicated by an intermittent tone and flashing lights at approximately 1/3-second intervals. A normal call is indicated by a steady lamp and an intermittent tone at approximately 8-second intervals.

The Tek-CARE® NC110N Nurse Call System includes three basic units, each essential for operation. These will be discussed individually and are as follows:

- Power & Control Unit
- Master Station
- Call Stations

The use of these basic units, in conjunction with wiring, housings and auxiliary equipment, make up a complete system.

## PK151A, PK152 Power & Control Units

The power & control unit utilizes a transformer which steps down the 120 VAC input to 24 VAC, 30 VA, which is then rectified, filtered and regulated to provide a stable 24 VDC for the rest of the system.

Control circuits are provided to detect the presence of normal or emergency calls and to provide steady or intermittent voltages to operate external devices with indications as follows:

Normal calls are indicated by a positive voltage applied to Terminal R by the calling remote station. Emergency calls are indicated by a positive voltage applied to terminal Q by the calling remote station.

## PK800A Secondary Power Supply

The secondary power supply accepts a 24 VAC input from the SS100 transformer. It rectifies, filters and regulates a +24 VDC output, which is provided on the two terminals labeled "24 VDC." A +5 VDC output is also available, but is not used in this application.

## NC110N Master Stations

The Master Station includes:

- Buzzer for audible signals.
- Annunciator lamps for call indication.
- Additional operating controls, including tone off and tone test switches and additional emergency and normal call indicators.

### **NC110A Master Stations**

The NC110A's design is based on the NC110N master station. The NC110N's control switches have been replaced with relays that have reliable control circuitry, which are operated via the buttons on the NC110A membrane switch. The NC110A uses an electronic oscillator circuit to generate call tones via an enclosed 45-ohm speaker. A simple digital counter keeps track of tone volume and is advanced by pressing the volume button.

The NC110A includes an isolated N/O relay contact for ancillary off-board call handling. An RC hold circuit keeps the contact closed during off cycles of the call indication LED. For this reason, the contact will remain closed for a few seconds after call activity at the station has ended.

### **SF100N, SF100/2, SF100C, SF101B, SF101N, SF101C, SF102 Call Stations**

The SF100N, SF100/2, SF100C, SF101C and SF102 Call Stations are for normal calls that use an LED visual indicator.

S.C.R. Q100 forms a latching circuit to maintain signaling after the momentary contact signal initiating push button has been released. S.C.R. Q100 is also used to reset the station when the call is canceled.

Call stations SF101B and SF101N have different features, but function in a similar manner.

### **SF151N, SF153N, SF155B, SF339 Emergency Stations and SF156B Code Station**

The SF155B Emergency Station is for emergency calls. In the emergency position, associated signal lights are disconnected from the normal signal terminals and connected to the emergency signal terminals.

Emergency stations SF151N, SF153N and SF339, and code station SF156B have different features, but function in a similar manner.

# System Installation

## Installation Procedure

- Step 1: Read the following instructions concerning system equipment and determine installation methods before proceeding.
- Step 2: Determine equipment location.
- Step 3: Install wiring.
- Step 4: Install housing.
- Step 5: Check wires.
- Step 6: Connect equipment.
- Step 7: Check connections.

## Equipment Locations

**NC110A, NC110N Master Stations:** Locate master stations within easy reach of operating personnel. Do not exceed operating temperature of 10° C–30° C.

**SF100C, SF101C, SF102 Call Stations:** Locate call stations where convenient for operation. Calls are placed on the SF100C and SF102 by means of a 6' long call cord switch, permitting easy operation by seated or prone patients. Calls are placed on the SF101C by means of a push button located on the station.

**SF155B, SF339 Emergency Stations and SF156B Code Station:** Locate emergency stations where convenient for operation. Avoid areas where direct contact with water may occur. The SF155B includes a 6' long pull cord permitting installation high enough to provide easy operation by the nurse and by seated or prone patients. The SF155B may be used without the cord as a pull down actuated switch.

**LI150B Duty Stations:** Locate duty stations as needed and where convenient for operation. Location should provide for unobstructed visibility of the call indicator.

**LI381 Corridor Lights:** Locate corridor lights in the corridor above or beside the door of the associated room. Location should provide for unobstructed visibility of the corridor light in both directions.

**LI382, LI382LED Corridor Zone Lights:** Locate corridor zone lights in the corridor area nearest the nurses central monitoring station. Location should provide for unobstructed visibility of each corridor zone light from the central location.

**SF301, SF302 Call Cords:** Insert call cord plugs into associated station jacks as indicated on the stations. Call cords provided are 6' or 10' in length.

**PK151A, PK152 Power & Control Units:** Locate the PK151A or PK152 and the IH151N junction box in an accessible area. Do not exceed operating temperature range of 10° C–30° C. Location should provide for convenient cable runs to remote and master stations. Cable run from the PK151A or PK152 to the NC110N Master Station must not exceed 100'.

**PK153 Third Priority Control Unit:** Locate the PK153 in the same location as the PK151A or PK152 Power & Control Unit.

**PK800A Secondary Power Supply:** Locate the PK800A in an accessible area within 2 feet of the PK151A or PK152 that it is to be connected to. Do not exceed operating temperature range of 10°C–30°C. The PK800A is for use in applications that exceed the current load capacity of the PK151A or PK152 (1 amp). The PK800A allows the current load to be increased to 3 amps. The FZ151 Fuse Assembly must be located between the PK800A and the PK151A or PK152. See *Figure 16* for actual FZ151 connection points.

**SS100 24 VAC 100 VA Transformer:** For use with the PK800A. Locate the SS100 within 3 feet of the PK800A Secondary Power Supply. Do not exceed operating temperature range of 10°C–30°C.

### Wiring Installation

Run wiring conduit from corridor light to corridor light and terminate at the PK151A or PK152 Power & Control Unit. Limit each run to 15 corridor lights and 600 feet of wire. Select conduit size to accommodate the following cables:

- 3 cond. #18 common to all call stations (except LI150B Duty Stations). Add 2 cond. #18 common if LI382 Corridor Zone Lights are used.
- Run 3 cond. #18 common from LI382 to PK151A or PK152 Power & Control Unit.
- 1 cond. #22 selective for each SF155B Emergency Station not used in conjunction with a call station.
- 4 cond. #22 to one LI150B Duty Station. Use 4 cond. #18 if feeding more than one duty station. Install a maximum of 4 duty stations per system. If more are needed, call factory for wiring information.

#### Station Wiring Layout:

**NC110A, NC110N Master Stations:** Run cable or conduit directly from the master station to the PK151A or PK152 Power & Control Unit and the IH151N Junction Box. Include the following:

- 5 cond. #18
- 1 cond. #22 for each SF100C/SF101C/SF102 Call Station.
- 1 cond. #22 for each SF155B Emergency Station not used in conjunction with a call station.

**SF100C, SF101C, SF102 Call Stations:** Run 4 cond. #22 directly to associated SF155B Emergency Station. If an emergency station is not used, run cable directly to the associated corridor light. If more than one call station is used in the same room, all stations run directly to the emergency station (if used).

**SF155B Emergency Stations:** Run 4 cond. #22 for each call station associated with the SF155B. Run cable directly to associated corridor light. If no call station is used, only 3 cond. #22 is needed from the SF155B to the corridor light.

**LI150B Duty Stations:** Run 4 cond. #22 to the PK151A or PK152 Power & Control Unit. Use 4 cond. #18 if feeding more than one duty station. Install a maximum of 4 duty stations per system. If more are needed, call factory for wiring information.

**Power Wiring:** Run conduit and 2 cond. #18 cable from the PK151A or PK152 Power & Control Unit and the IH151N Junction Box to 117 VAC - 60 cycle power source. Do not connect power.

Refer to *Figures 9–10* for typical system wiring and cable sizes.

**Housing Installation**

**NC110A Master Station:**

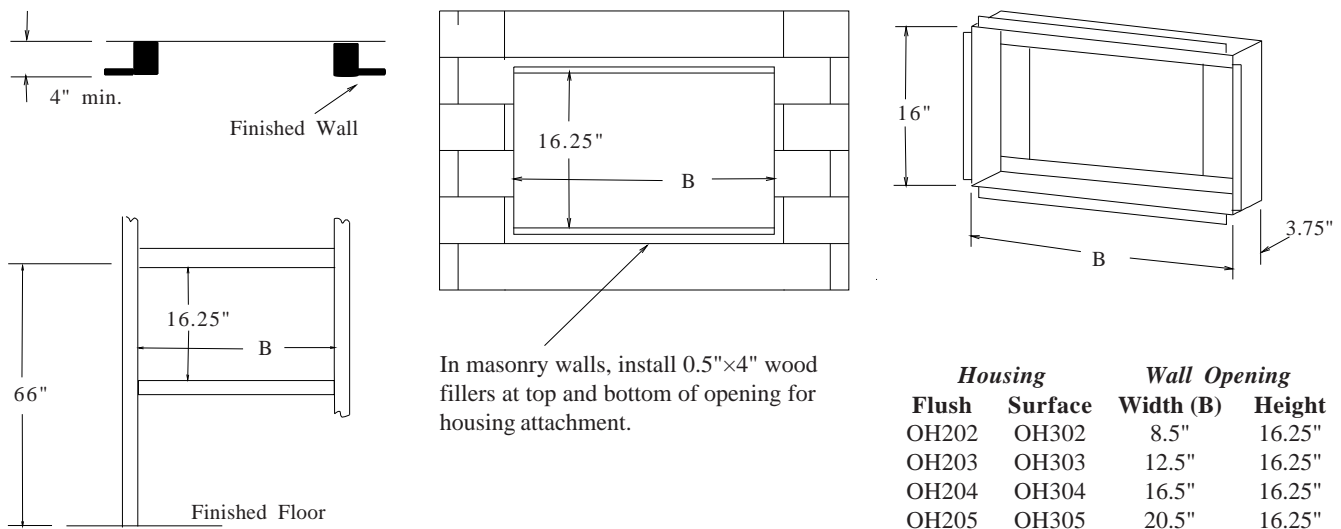
The NC110A is a desktop unit. Locate the PL116 wall plate directly behind the desk to accommodate the NC110A. Mount the wall plate to a four-gang electrical backbox with a three-gang mud ring (TekTone® part numbers IH353 and IH352 respectively). Connect the NC110A to the wall plate using the provided 8-wire, RJ-terminated cable (CA045) and fixed 50-wire ribbon cable (CA046). Gather extra length in the ribbon cable and tie as shown. See *Figure 11* for unit placement.

**NC110N Master Station:**

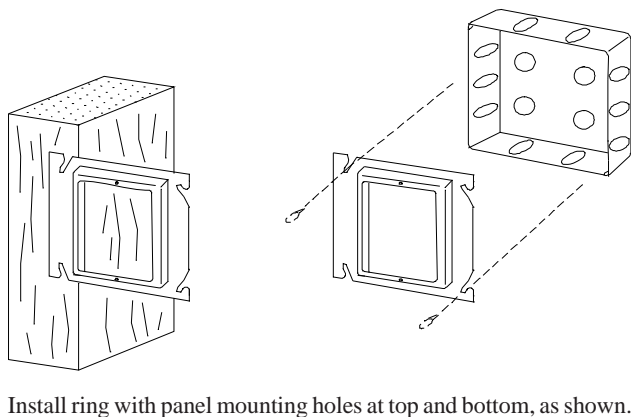
**Flush Wall Mounting:** Provide wall cutout as shown in *Figure 5*. Fit back box and frame assembly into prepared opening. Fasten assembly in place using screws. Back box must be TekTone® OH200 Series.

**Surface Wall Mounting:** Fasten box and frame assembly to wall through holes provided in back of box. Use suitable fasteners. Back box must be TekTone® OH300 Series.

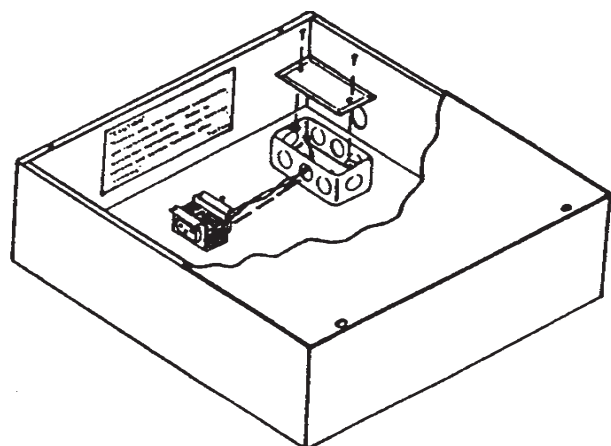
**Figure 5—Master Panel Housing Chart and Wall Cut-Out Details**



**Figure 6—Ring & Back Box for Call, Emergency, Code & Duty Stations, and Corridor & Zone Lights**



**Figure 7—SS106 Transformer Installation**



**SF100C, SF101C, SF102 Call Stations, SF155B Emergency Station:** Install single gang ring (or single gang ring and double gang box) as shown in *Figure 6* for each call and emergency station in the system. Ring and back box must be UL<sup>®</sup> approved. Minimum dimensions of back box must be not less than 4"×4"×1.5". Minimum opening on ring must be not less than 1.75"×2.75". Minimum clearance from live parts on station to dead metal parts must be not less than 0.5".

**LI150B Duty Stations:** Install single gang ring (or single gang ring and double gang box) as shown in *Figure 6* for each duty station. Ring and back box must be UL<sup>®</sup> approved. Minimum dimensions are the same as for the call/emergency stations listed previously.

**LI381 Corridor Lights, LI382 Corridor Zone Lights:** Install double gang ring (or double gang ring and double gang box) as shown in *Figure 6* for each corridor light in system. Ring and back box must be UL<sup>®</sup> approved. Minimum dimensions of back box must be not less than 4"×4"×1.5". Minimum opening of ring must be not less than 2.75"×2.75". Minimum clearance from live parts of station to dead metal parts must be not less than 0.5".

**LI382LED Corridor Zone Lights:** Install standard one- or two-gang box with one- or two-gang ring as shown in *Figure 6* for each corridor light in system. Ring and back box must be UL<sup>®</sup> approved. Minimum clearance from live parts of station to dead metal parts to be not less than 0.5".

**PK151A or PK152 Power & Control Unit, IH151N Junction Box:** Fasten IH151N Junction Box to wall using suitable fasteners. Mount PK151A or PK152 inside junction box. Any alternate junction box must be UL<sup>®</sup> approved. Minimum dimensions of junction box must be not less than 12"×12"×4". Minimum clearance from live parts to dead metal parts on housing must be 1".

Install SS106 Transformer in junction box as shown in *Figure 7*. **Do not connect transformer primary to power source until entire installation is completed and checked for shorts and grounds.**

Install transformer connection box as shown in *Figure 7*. Transformer box must be UL<sup>®</sup> approved. Minimum dimensions must be not less than 1.75"×3.75"×1.5". The junction box, transformer and power & control unit are also available preassembled from the factory as part number IH151NK.

**PK800A Secondary Power Supply:** Fasten PK800A Secondary Power Supply to wall using suitable fasteners.

**SS100 24 VAC 100VA Transformer:** Fasten SS100 24 VAC 100 VA Transformer to wall using suitable fasteners. **Do not connect transformer primary to power source until entire installation is completed and checked for shorts and grounds.**

### Wire Checkout

Use an ohmmeter or other continuity checking device to test wires for shorts or grounds. If shorts or grounds are encountered, find and correct the problem before continuing. Make sure minimum number of conductors needed for all of the equipment being used in the system are available.

### Wire Connections

Use crimp-style connectors for all wire connections. Do not use wire nuts.

**NC110A Master Station:** Wire the PL116 Wall Plate as shown in *Figure 12*.

**NC110N Master Station:** No internal wiring is necessary for the NC110N Master Station.

**SF100C, SF101C, SF102 Call Stations:** Connect wires as shown in *Figures 9–10*.

**SF155B Emergency Stations:** Connect wires as shown in *Figures 9–10*.

**LI150B Duty Stations:** Connect wires as shown in *Figures 9–10*.

**LI381 Corridor Lights, LI382 and LI382LED Corridor Zone Lights:** Connect wires as shown in *Figures 9–10*.

**PK151A, PK152 Power & Control Unit:** Connect wires as shown in *Figures 9–10*. Also connect secondary from the SS106 Transformer (24 VAC, 30 VA connections) to the PK151A or PK152 as shown in *Figures 9–10*. **Do not connect transformer primary to power source until entire installation is completed and checked for shorts and grounds.**

**PK800A Secondary Power Supply:** Connect wires as shown in *Figure 16*.

**SS100 24 VAC 100 VA Transformer:** Connect wires as shown in *Figure 16*. **Do not connect transformer primary to power source until entire installation is completed and checked for shorts and grounds.**

### Connections Checkout

Recheck all connections to equipment. If all wires and connections are satisfactory, connect primary coil of SS106 Transformer to source of 117 VAC 60 cycles (40 watts max.) and operation of system can be checked according to *System Test Instructions* next in this section.

### System Test Instructions

Before proceeding with a system test, all stations should be set to normal conditions as follows:

**NC110A Master Station:** No initialization is necessary.

**NC110N Master Station:** All push buttons should be in normal **OUT** position. If depressed, the **TONE OFF** button may be released by pressing the button and then releasing it.

**SF100N, SF100/2, SF100C, SF102 Call Stations:** If the call cord push button has been pressed, reset the station by pressing the **CANCEL** button.

**SF101N, SF101C Call Stations:** If the call button has been pressed, reset the station by pressing the **CANCEL** button.

**SF153N, SF339 Emergency Stations:** If the call/cancel switch is pressed to the **IN** position, press the switch again or twist the switch to the **OUT** position to reset the station.

**SF151N, SF155B Emergency Stations and SF156B Code Station:** If the call cord has been pulled or the switch has been pulled down, reset the station by pushing the switch up.

**LI150N, LI150B Duty Stations:** Push the **TONE OFF** switch up.



### System Checkout and Testing

**SF100N, SF100/2, SF100C, SF101N, SF101C, SF102 Call Stations:** Test call stations one at a time. Initiate a call on each station. Press the button on the end of the call cord for SF100N, SF100/2, SF100C, SF102 Call Stations. Press the call button for SF101N, SF101C Call Stations. Check for operation of the following signals:

- The **CALL PLACED** lamp on the call station should be illuminated.
- The LI381, LI382 or LI382LED Corridor Light near the room entrance should be illuminated.
- On the NC110N Master Station, the call lamp should be illuminated and the associated station selector lamp (marked to identify the calling station) should be illuminated. A slowly repeating audible call tone should be heard. The normal call tone may be silenced by the **TONE OFF** button, which should be illuminated to indicate tone silencing.
- On all LI150B Duty Stations, the **CALL PLACED** lamp should be illuminated, and a slowly repeating audible call tone should be heard. The normal call tone may be silenced by the **TONE OFF** button.

Reset the call at the call station: Press the **CANCEL** button on SF100N, SF100C, SF102, SF101N and SF101C stations. All signals should be canceled.

**SF151N, SF153N, SF155B, SF339 Emergency Stations and SF156B Code Station:** Test stations one at a time. Initiate a call on each station. Pull the call cord on the SF151N Emergency Station. Push the switch to the **IN** position on the SF153N, SF339 Emergency Stations. Slide the switch to the **DOWN** position or pull the call cord on the SF155B Emergency Station. Slide the switch to the **DOWN** position on the SF156B Code Station. Check for operation of the following signals:

- The **CALL PLACED** lamp should be flashing
- The LI381 Corridor and LI382/LI382LED Corridor Zone Light near the room entrance should be flashing.
- On the NC110N Master Station, the call lamp should be flashing, the emergency lamp should be flashing, and the associated station selector lamp (marked to identify the calling station) should be flashing. An intermittent audible call tone should be heard. Pressing the **TONE OFF** button must not cancel the emergency call tone.
- On all LI150B Duty Stations, the call lamp should be flashing, and an intermittent audible call tone should be heard. The **TONE OFF** button must not cancel the emergency call tone.

# System Maintenance Instructions

Most of the equipment and parts used in the Tek-CARE® NC110N Nurse Call System are not user serviceable and cannot be replaced or repaired by the end user. Equipment must be repaired by qualified service personnel only. Parts that are user serviceable are listed in the following section and their replacement explained.

## NC110A Master Stations

There are no user replaceable components on the NC110A. Clean the membrane switch with a damp cloth as needed. Check for unintentional button presses which may occur during cleaning.

## NC110N Master Stations

Refer to *Figure 8* to identify replacement parts. A full list of replacement parts and numbers appears in the *Replacement Parts* section.

### *Selector Lamp Lens Replacement:*

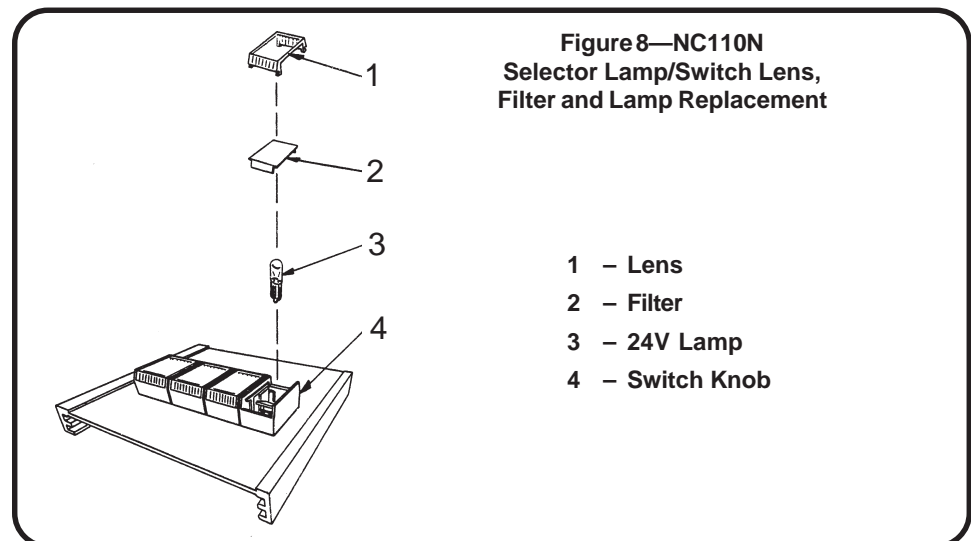
- Remove lens by squeezing top and bottom together and pulling away from panel.
- Replace with same color lens by pushing new lens towards panel. The lens should snap into place on the selector lamp/switch knob with a noticeable click.

### *Selector Lamp Filter Identification:*

- Remove lens by squeezing top and bottom together and pulling away from panel.
- Remove white filter by lifting it out of the selector lamp/switch knob.
- Identify filter by room number or other means using dry transfer lettering, labels, or other similar methods. Be sure identified filter is replaced in knob so that lettering is readable right side up.
- Replace lens by pushing it towards panel. The lens should snap into place on the selector lamp/switch knob with a noticeable click.

### *Defective Lamp Replacement:*

- Remove lens and filter by methods described above.
- Using needle-nosed pliers, tweezers or similar tool, pull lamp out of socket by gripping lamp at sides and moving it from side to side as it is pulled away from the panel.  
**WARNING: Do not squeeze too tightly, or it will break.**
- Replace lamp by holding with tool and pushing into socket. Be sure lamp is turned so that the base is lined up with the slot in the socket. Lamp must be pushed in below the level of the filter.



## System Maintenance Instructions

---

- Push test button to make sure lamp has been placed in socket properly. If lamp does not light, try pressing more firmly into socket. If lamp still does not light, repeat steps above with new lamp until one works properly.
- Replace lens and filter in selector lamp/switch knob as previously described.

### PK151A, PK152 Power & Control Units

There are no user serviceable parts in the PK 151 A and PK152 Power & Control Units. Notify qualified service personnel for repair or replacement.

### PK153 Third Priority Control Unit

There are no user serviceable parts in the PK153 Third Priority Control Unit. Notify qualified service personnel for repair or replacement.

### PK800A Secondary Power Supply

The only user serviceable part is a 4A, 125 VAC fuse (1.25"×0.25").

- Disconnect power to the associated SS100 transformer. If the SS100 is hard wired, locate the associated breaker and turn it off. If a means cannot be established to remove power to the SS100, then contact qualified service personnel and do not proceed further. The SS106 powering the associated PK151 A or PK152 should also be powered down in the same fashion.
- Once power has been disconnected, firmly grasp the black fuse holder knob on the side of the PK800A, push in and rotate it counterclockwise. Pull out on the knob to expose the fuse.
- Remove the fuse and insert the new fuse. Reinsert fuse holder knob. Restore power to the system.

For repair or replacement of any other parts, contact qualified service personnel. A list of replacement parts and numbers appears in the *Replacements Parts* section.

### FZ151 In-Line Fuse Holder

The only user serviceable part is a 4A, 125 VAC fuse (1.25"×0.25").

- Disconnect power to the associated SS100 transformer. If the SS100 is hard wired, locate the associated breaker and turn it off. If a means cannot be established to remove power to the SS100, then contact qualified service personnel and do not proceed further. The SS106 powering the associated PK151 A or PK152 should also be powered down in the same fashion.
- Once power has been disconnected, firmly grasp both ends of the fuse holder, push in and rotate in opposite directions. Pull out on both ends to expose the fuse.
- Remove the fuse and insert the new fuse. Put fuse holder back together and verify that both pieces are interlocked. Restore power to the system.

For repair or replacement of any other parts, contact qualified service personnel. A list of replacement parts and numbers appears in the *Replacements Parts* section.

### SF100N, SF100/2, SF100C, SF102 Call Stations

The only user serviceable part on these stations are the call cords. To replace:

- To remove the call cord, grip end of plug firmly and pull straight away from call station.
- To replace the call cord, hold by end of plug and push straight into call cord jack on call station.

## System Maintenance Instructions

- To test, push the button at the end of the call cord. The **CALL PLACED** lamp should illuminate. Push the **CANCEL** button to cancel the call.

For repair or replacement of any other parts, contact qualified service personnel. A list of replacement parts and numbers appears in the *Replacements Parts* section.

### SF101N, SF101C Call Stations

There are no user serviceable parts on the SF101N, SF101C Call Stations. Notify qualified service personnel for repair department

### SF151N, SF153N, SF155B, SF339 Emergency Stations and SF156B Code Station

There are no user serviceable parts on the SF151N, SF153N, SF155N, SF339 Emergency or SF156B Code Stations. Notify qualified service personnel for repair or replacement.

### LI150N, LI150B Duty Stations

There are no user serviceable parts on the LI150N, LI150B Duty Stations. Notify qualified service personnel for repair or replacement.

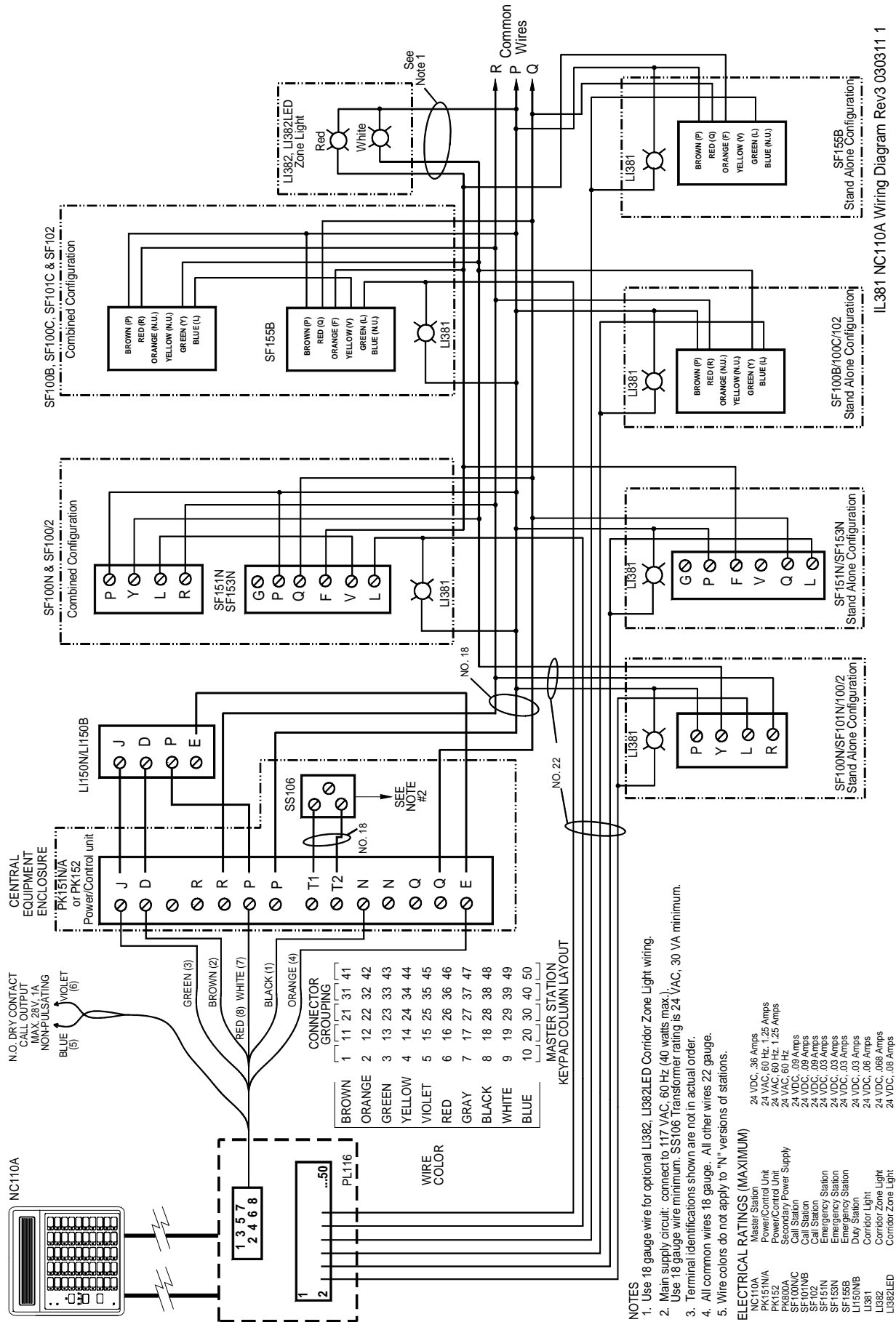
### LI381 Corridor and LI382 Corridor Zone Lights

- To remove cover, grip firmly by sides, and pull cover away from plate.
- To remove bulb, make sure that no call is placed, then push bulb in towards plate. Turn bulb counterclockwise and pull bulb out of socket. On LI382, remove red bulb cover before removing bulb.
- To replace bulb, hold by glass part and push metal end into socket. When resistance is encountered, turn bulb clockwise until it falls into socket. (Metal part should be below the top of the socket.) Push bulb again and turn clockwise until bulb stops turning, and then release. On LI382, replace red bulb cover. Be sure to place bulb cover over the same bulb from which it was removed.
- To test light, place a call at the associated station. If light still does not work, repeat steps above until corridor light and/or corridor zone lights function properly.
- To replace cover, reverse instructions for removal.

### Replacement Parts

| <i>Part No.</i> | <i>Description</i> | <i>Used For</i>                                    |
|-----------------|--------------------|--|
| FZ010           | 4A Fuse            | PK800A Secondary Power Supply and FZ151 Fuse Asst. |
| LI014           | 24V Lamp           | NC110N Control and Selector Module Lamps           |
| LI028           | 28V Lamp           | LI381, LI382 Corridor Lights                       |
| RP021           | Blank Filter       | NC110N Selector Button Label                       |
| RP022           | Orange Lens        | NC110N Tone Test Button and Selector Buttons       |
| RP024           | Green Lens         | NC110N Tone Off Button                             |
| RP027           | Clear Lens         | NC110N Emergency Button                            |
| RP028           | Yellow Lens        | NC110N Call Button                                 |
| RP037A          | Red Bulb Cover     | LI382 Corridor Zone Lights                         |
| SF301           | Call Cord          | SF100N, SF100/2, SF100C, SF102 Call Stations       |
| SF302           | Call Cord Dual     | SF100N, SF100/2, SF100C, SF102 Call Stations       |

# Figure 9—NC110A Wiring Diagram



- NOTES**
1. Use 18 gauge wire for optional LI382, LI382LED Corridor Zone Light wiring.
  2. Main supply circuit: connect to 117 VAC, 60 Hz (40 watts max).
  3. Use 18 gauge wire minimum. SS106 Transformer rating is 24 VAC, 30 VA minimum.
  4. Terminal identifications shown are not in actual order.
  5. All common wires 18 gauge. All other wires 22 gauge.
  6. Wire colors do not apply to "N" versions of stations.

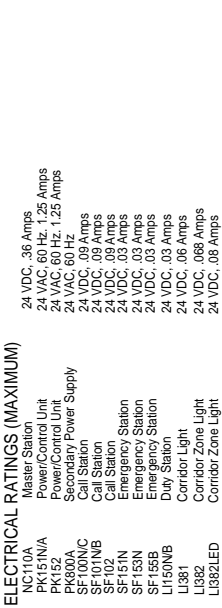
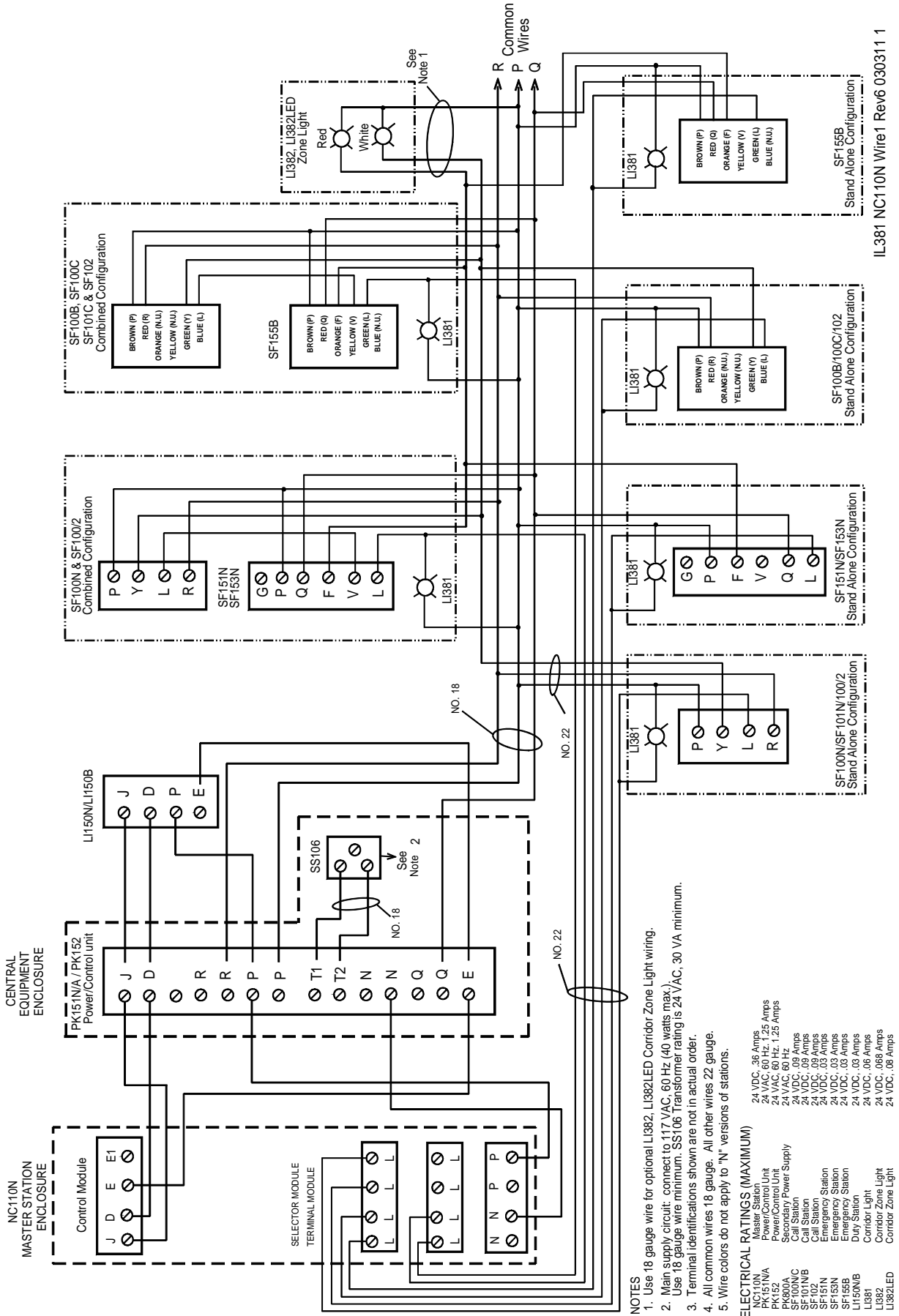


Figure 10—NC110N Wiring Diagram



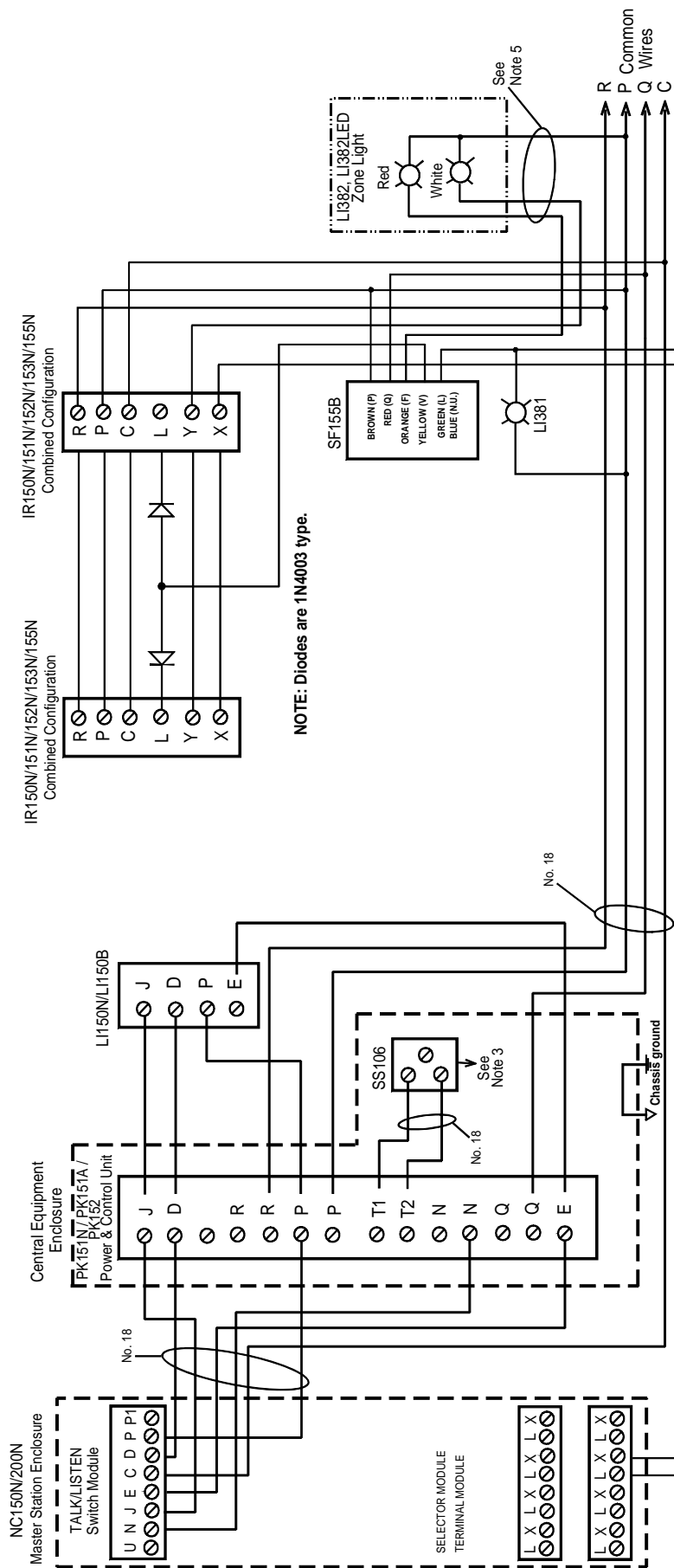
IL381 NC110N Wire1 Rev6 030311 1

- NOTES**
1. Use 18 gauge wire for optional LI382, LI382LED Corridor Zone Light wiring.
  2. Main supply circuit: connect to 117 VAC, 60 Hz (40 watts max.). Use 18 gauge wire minimum. SS106 Transformer rating is 24 VAC, 30 VA minimum.
  3. Terminal identifications shown are not in actual order.
  4. All common wires 18 gauge. All other wires 22 gauge.
  5. Wire colors do not apply to "N" versions of stations.

**ELECTRICAL RATINGS (MAXIMUM)**

|                        |                          |
|------------------------|--------------------------|
| Master Station Unit    | 24 VDC, .35 Amps         |
| Power/Control Unit     | 24 VAC, 60 Hz, 1.25 Amps |
| Secondary Power Supply | 24 VAC, 60 Hz, 1.25 Amps |
| PK152                  | 24 VDC, .09 Amps         |
| PK800A                 | 24 VDC, .09 Amps         |
| SF100NC                | 24 VDC, .09 Amps         |
| SF101NB                | 24 VDC, .09 Amps         |
| SF101NB                | 24 VDC, .09 Amps         |
| SF151N                 | 24 VDC, .03 Amps         |
| SF153N                 | 24 VDC, .03 Amps         |
| SF155B                 | 24 VDC, .03 Amps         |
| SF155NB                | 24 VDC, .03 Amps         |
| LI150NB                | 24 VDC, .06 Amps         |
| LI381                  | 24 VDC, .06 Amps         |
| LI382                  | 24 VDC, .068 Amps        |
| LI382LED               | 24 VDC, .08 Amps         |

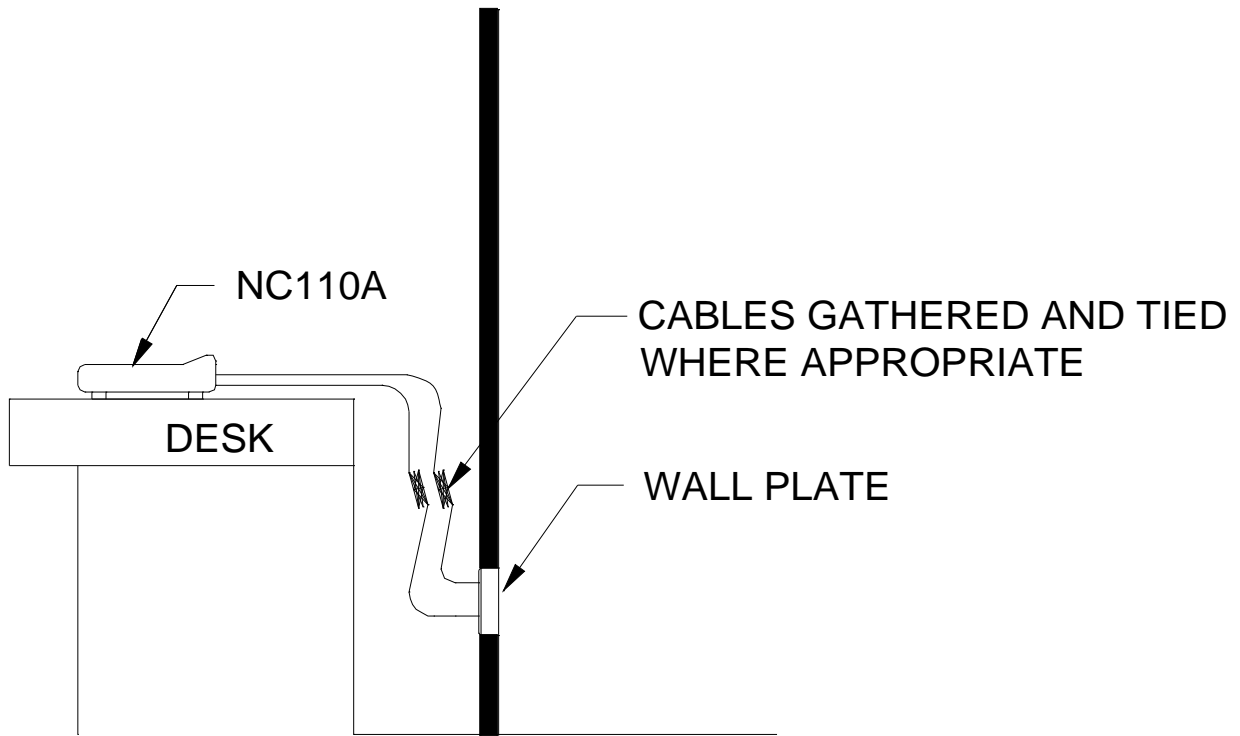
**Figure 10a—NC150N, NC200N, Two Stations in Parallel**



- NOTES**
1. Selector switch module shown is representative of NC150N master station.
  2. Terminal identifications shown are not in actual order.
  3. Main supply circuit: Connect to 117 VAC, 60 Hz (40 watts max.). Use 18 gauge wire minimum.
  4. SS106 Transformer rating is 24 VAC, 30 VA minimum. Use shielded cable if not in a metal conduit. If shielded cable is used, shield wire replaces conductor connected to terminal C on talk/listen module on NC150N.
  5. Use 18 gauge wire for optional L1382, L1382LED zone light wiring.

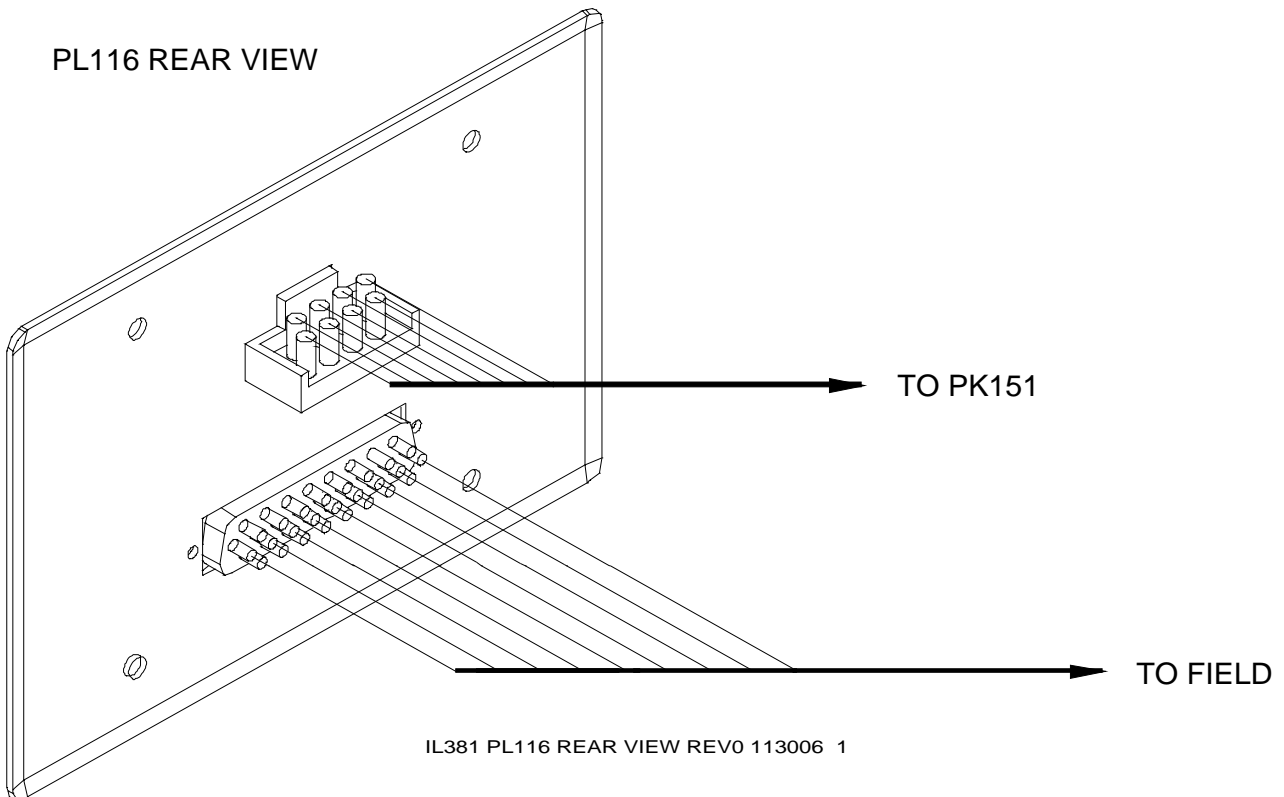
IL380 IL381 NC150N NC200N 2 Stations Parallel Rev5 030311 1

**Figure 11—NC110A Housing Installation Diagram**



IL381 NC110A TYPICAL INSTALLATION REV0 112806 1

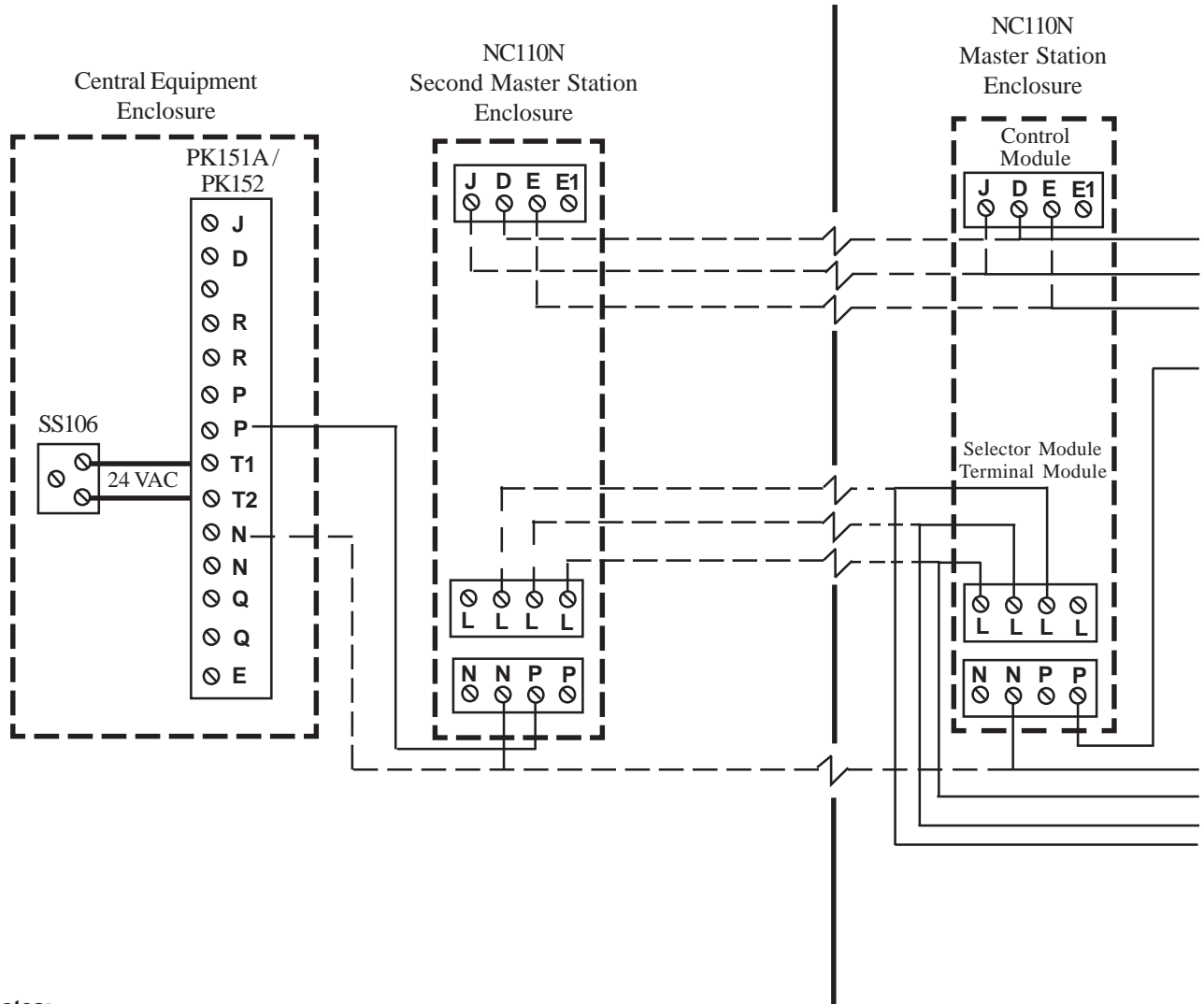
**Figure 12—PL116 Wall Plate Wiring Diagram**



IL381 PL116 REAR VIEW REV0 113006 1



**Figure 13—NC110N Second Master Wiring Diagram**

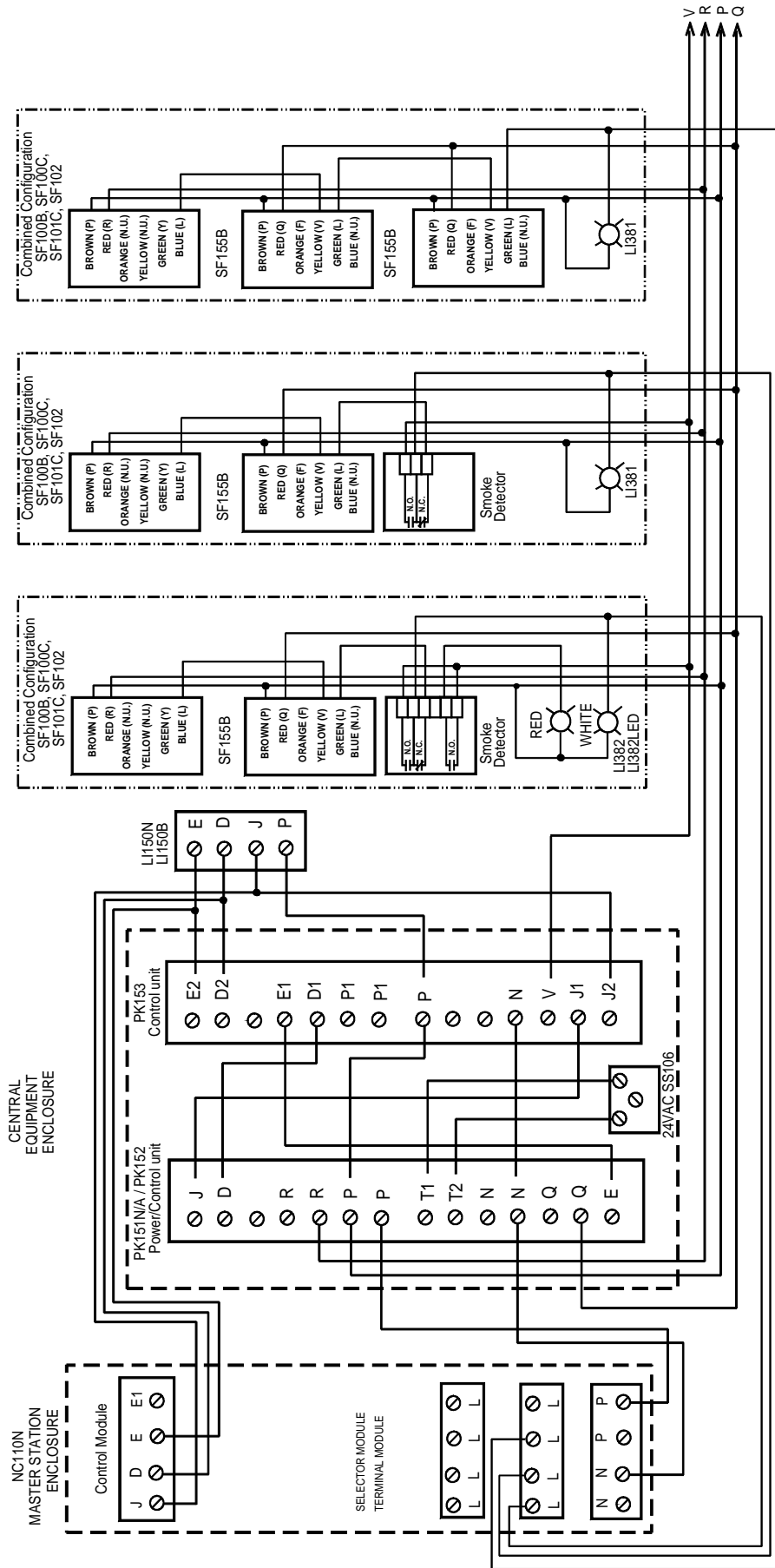


**Notes:**

1. Main supply circuit, connect to 117 VAC, 60Hz (40 watts max). Use #18 gauge wire minimum. SS106 transformer rating is 24 VAC, 30VA maximum.
2. Terminal identifications shown are not in actual order.
3. All common wires are #18 gauge. All other wires are #22 gauge.
4. The secondary PK151A or PK152 uses terminals P (power to second master) and N (common) only. All other functions are supplied by the primary PK151A or PK152.

Rev. 0 • 10/07/96 • MEL  
 Rev. 1 • 05/24/10 • RLT  
 Rev. 2 • 10/05/10 • RLT

Figure 14—PK153 Wiring Diagram

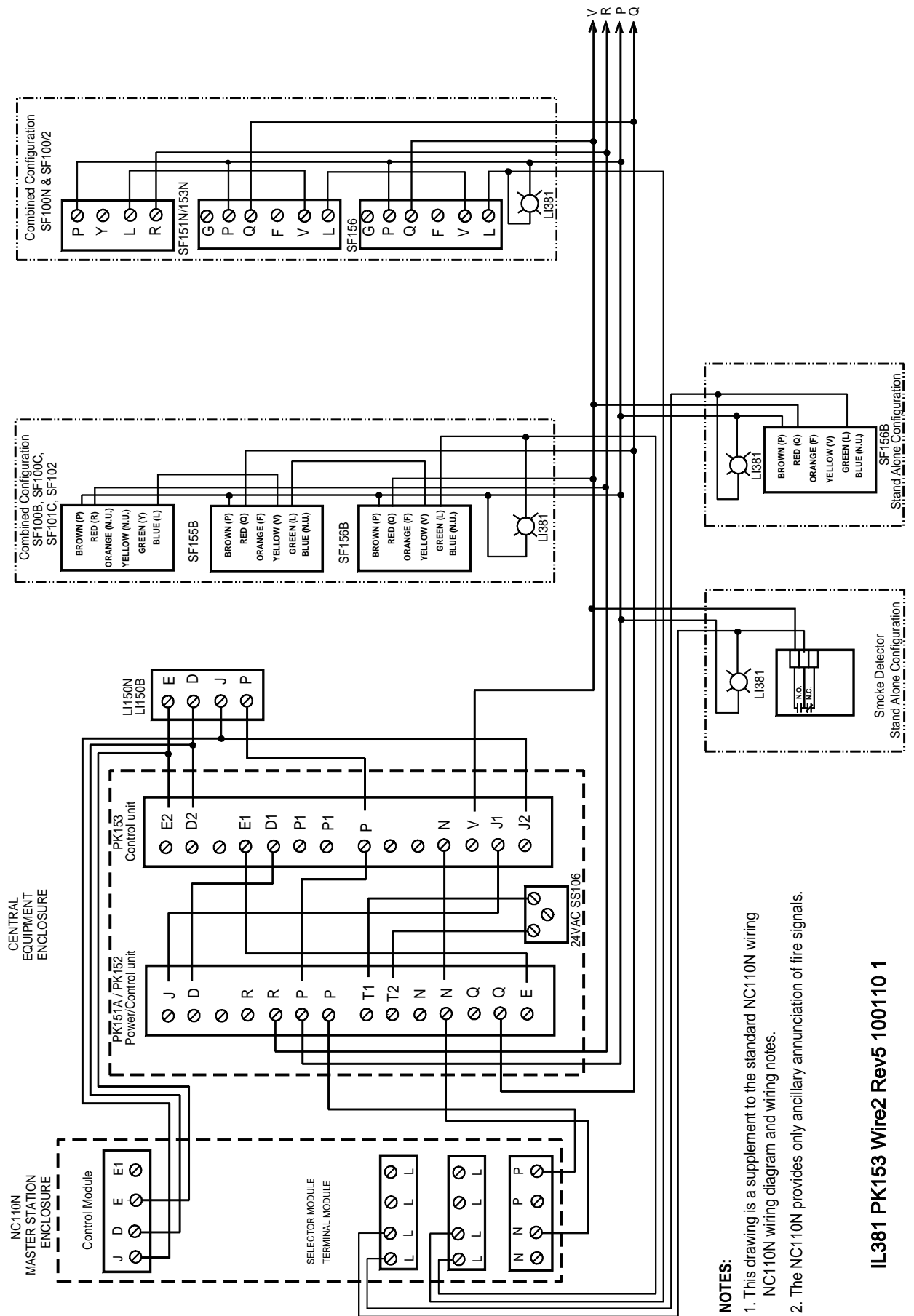


IL381 PK153 Wire1 Rev4 030311 1

**NOTES:**

1. This drawing is a supplement to the standard NC110N wiring diagram and wiring notes.
2. The NC110N provides ancillary annunciation only of fire signals.

**Figure 15—PK153 Wiring Diagram with SF156B Code Station**

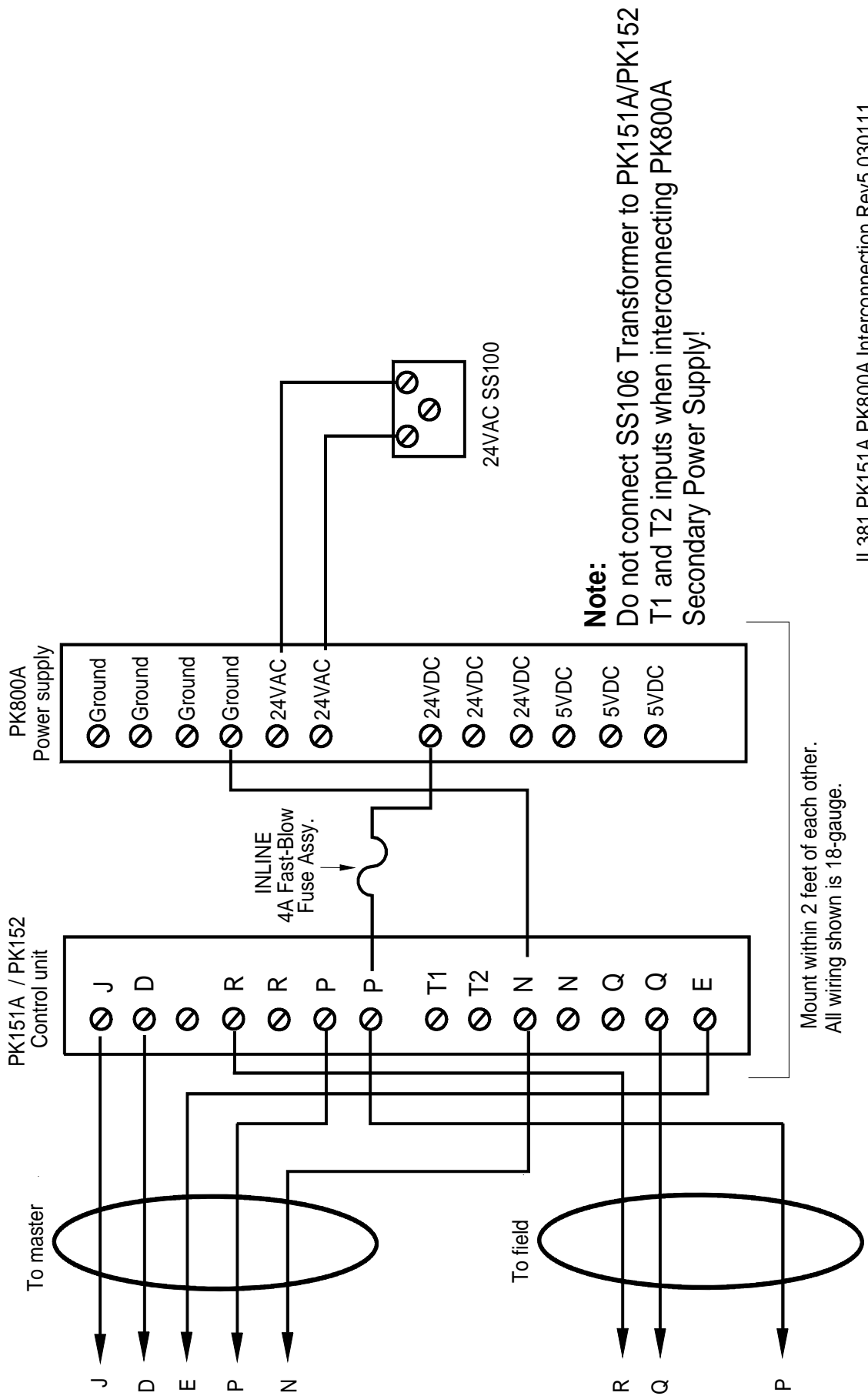


**NOTES:**

1. This drawing is a supplement to the standard NC110N wiring NC110N wiring diagram and wiring notes.
2. The NC110N provides only ancillary announcement of fire signals.

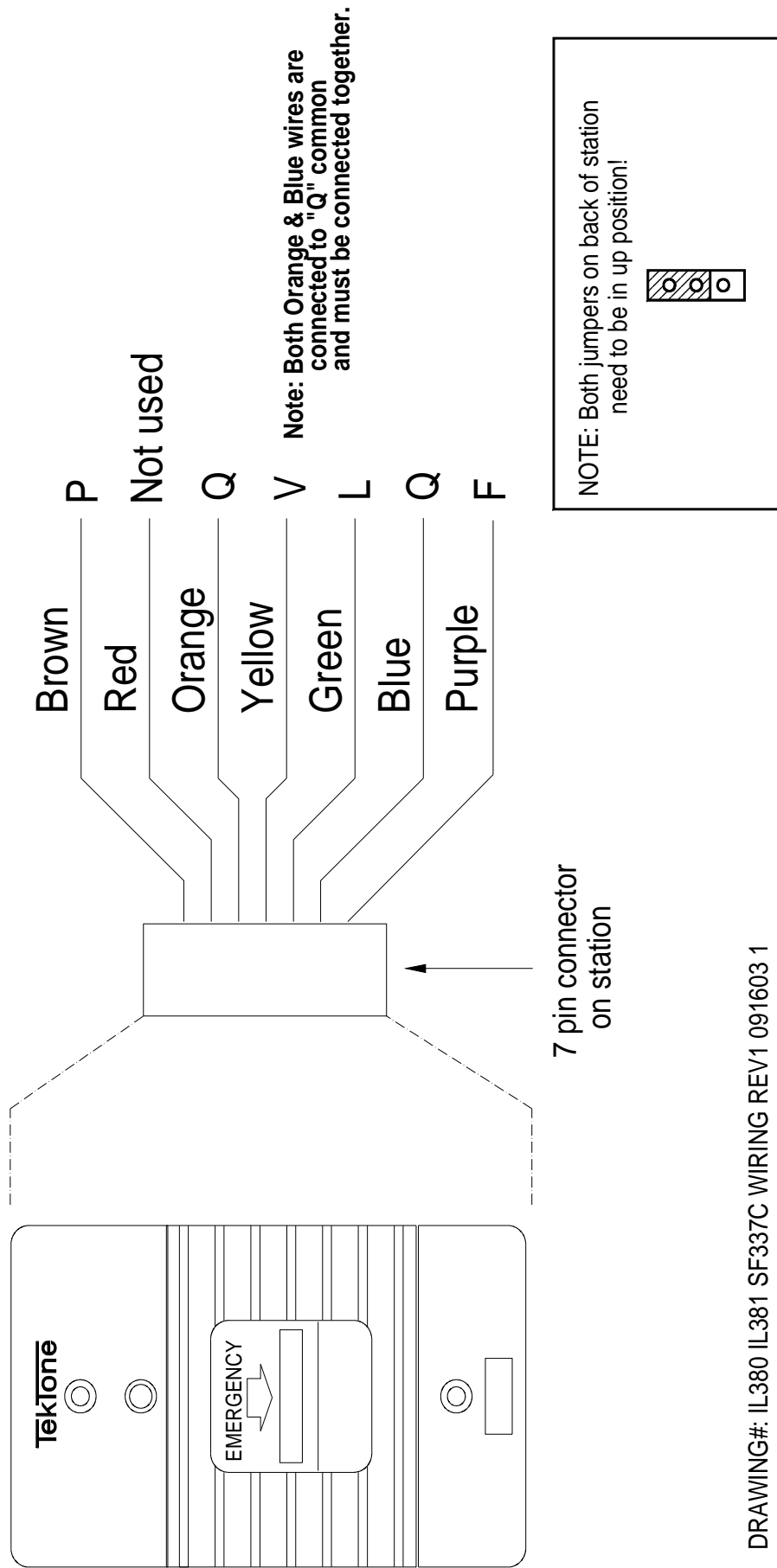
**IL381 PK153 Wire2 Rev5 100110 1**

**Figure 16—PK151A or PK152 to PK800A Interconnection**



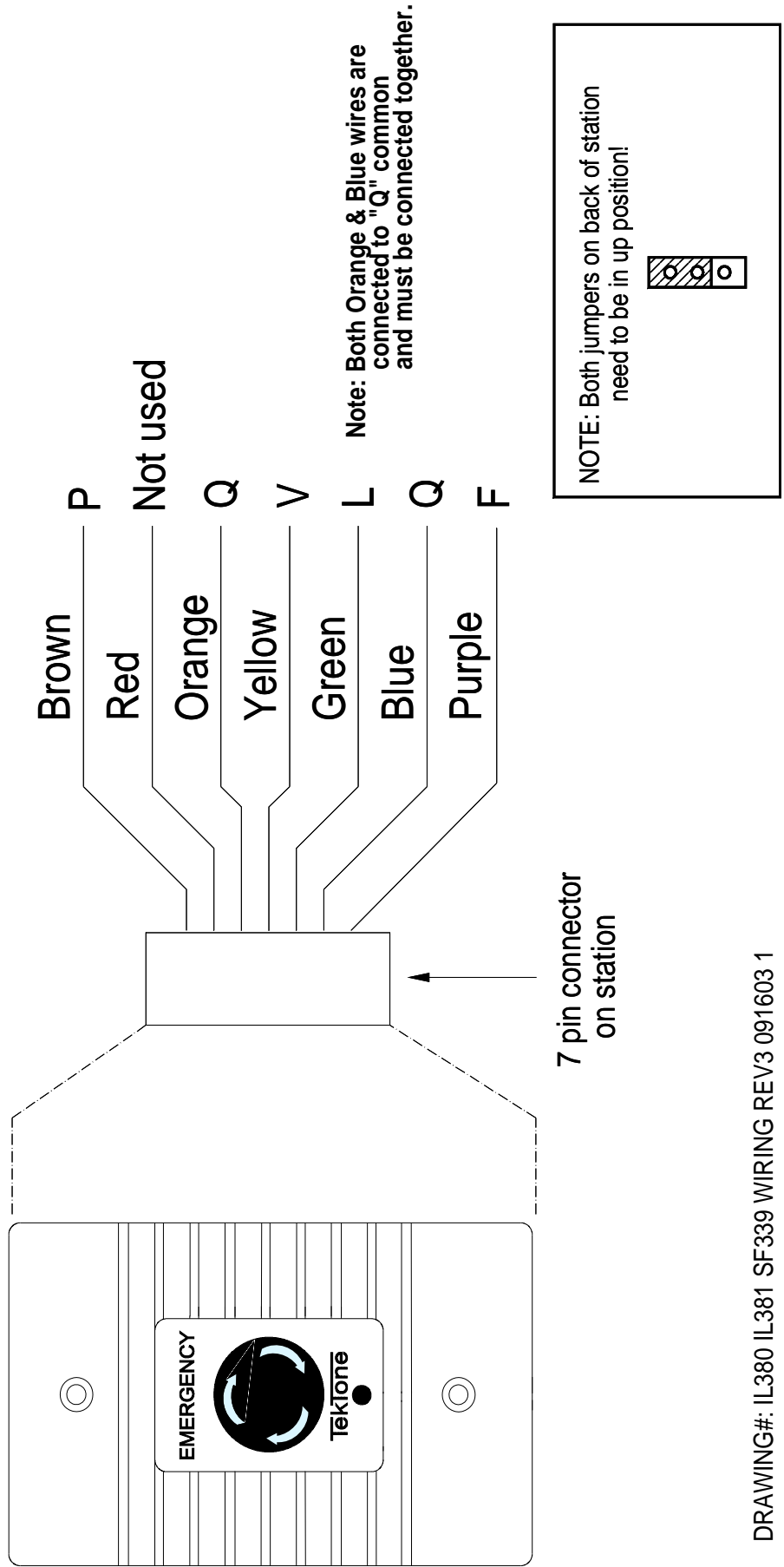
IL381 PK151A PK800A Interconnection Rev5 030111

**Figure 17—SF337C Cross Reference Diagram**



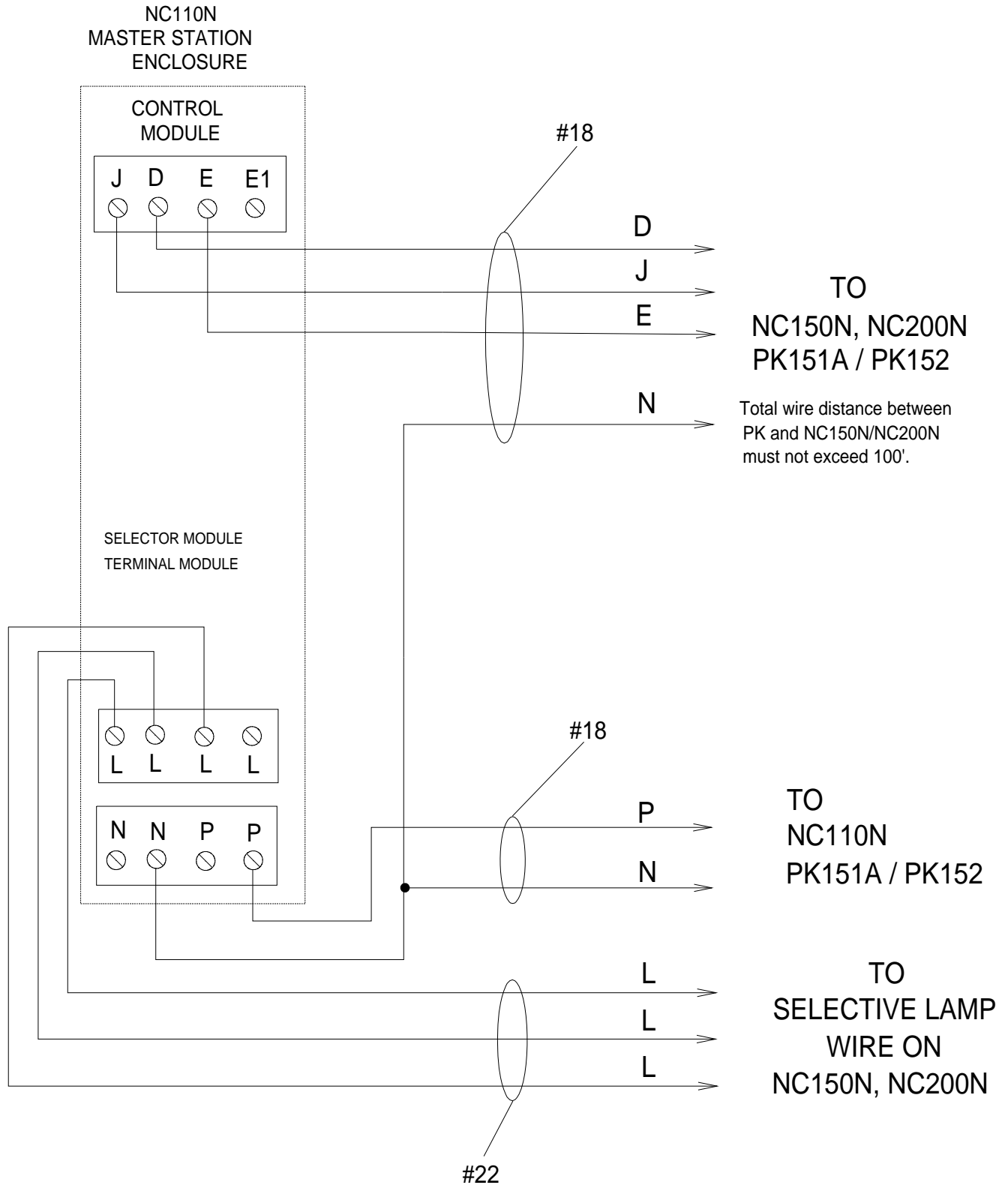
DRAWING#: IL380 IL381 SF337C WIRING REV1 091603 1

**Figure 18—SF339 Cross Reference Diagram**



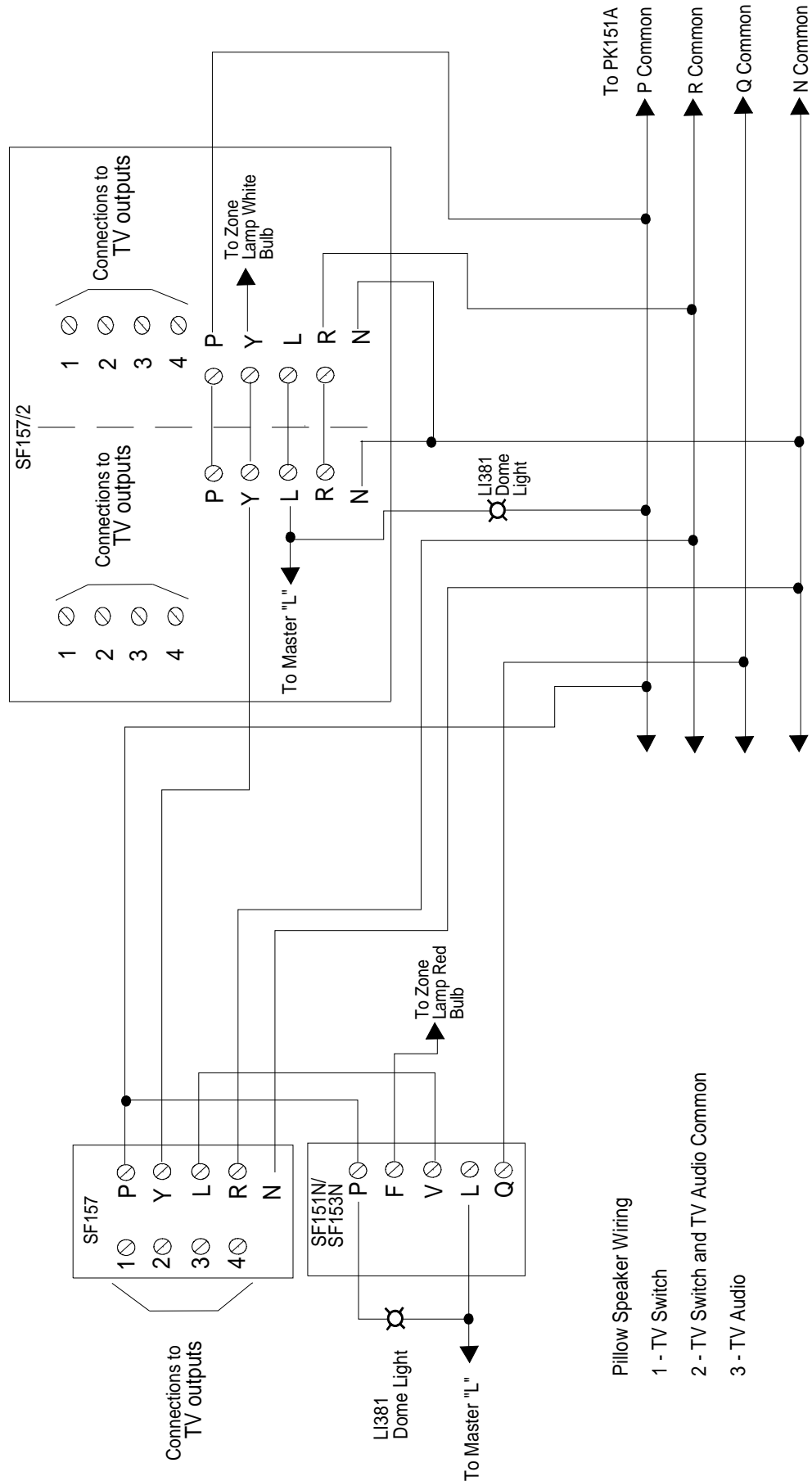
DRAWING#: IL380 IL381 SF339 WIRING REV3 091603 1

**Figure 19—NC110N Hookup to NC150N, NC200N**



IL381 NC110N NC150N NC200N Hookup Rev2 100110 1

**Figure 20—SF157 and SF157/2 Wiring Diagram**



\*Note - Order of terminals has been changed for drawing purposes.

**IL381 SF157 SF157-2 Wire Rev0 122602 1**