



LI404B Strobe Wiring Diagram and Installation Instructions

IL554
Section A
Rev. 7 - 12/2007

IMPORTANT NOTES

Before applying power to the system, make certain that all wires are free from shorts or grounds. Failure to do so could result in damage to the system and to the devices attached. The LI404B Strobe is not a weather resistant device and is not intended to be used for outdoor applications. Do not install this unit in areas of high humidity, direct sunlight, or high ambient light, as this will minimize the effectiveness of the strobe. The TekTone® warranty is void if this device is installed or used in any manner other than that described on this installation sheet (IL554).

PROCEDURES

1. Read the installation instructions to determine equipment location and installation method.
2. Install the housing and wiring.
3. Install the equipment.
4. Check all wiring and connections.
5. Apply power and check operation.

LOCATIONS

The LI404B Strobe mounts in most standard single and dual gang electrical boxes. If the strobe is to be used as a primary visual indicator, locate the boxes at a minimum of 6' (1.8 m) from the floor or 6" (15 cm) from the ceiling. For secondary signaling purposes, locate the electrical boxes at a minimum of 6" from the floor. It is recommended that the LI404B Strobe be mounted on a wall opposite its associated apartment station, but within sight of it.

HOUSINGS

If needed, mount the provided adapter plate to the electrical box, keeping the surface marked "THIS SIDE TO WALL" facing away from the room. Use the hardware included with the strobe to mount the adapter plate. See supplemental documentation included with the strobe for additional mounting information.

WIRING

Route all cables away from AC power wiring, transformers, fluorescent lighting, light dimmers, or other electrical devices. If AC/RF interference is a concern, use shielded cables. Protect the cables from damage during installation. A minimum of 18 gauge wire must be used. The maximum cable length of 750' (228 m) per run applies to cabling from the PK amplifier and includes any remote station wiring that is used. Select conduit entrance to allow space in the electrical box for the LI404B's protruding circuitry and wiring.

CONNECTIONS

Remove the 4-pin connector from the unit (if attached) and make the connections as shown in the wiring diagram specific to the system being used. The maximum number of lights per call point (apartment) is two (2) for PK-powered systems. Up to four (4) lights per station may be installed when a separate power supply is used (PK601A). Insulate all wire connections and verify them before reconnecting and applying power to the system.

TESTS

Install the device in its housing, being careful not to over-tighten any screws. Apply power and check each unit in the system for operation in accordance with the operating instructions. If the unit fails to operate as required, review the instructions and re-check all wiring. For other problems, see the individual PK amplifier installation instructions for troubleshooting methods.

Periodic cleanings, inspections and tests must be made to ensure proper operation and continued appliance life.

ALPHA COMMUNICATIONS® • 42 Central Drive • Farmingdale, NY 11735-1202

Toll-Free Technical Line: 1-800-666-4800 • Phone: (631) 777-5500 • Fax: (631) 777-5599

Website: www.alpha-comm.com • Email: info@alpha-comm.com

LI404B Wiring Diagram for Retrofit System with Single Strobe

(Refer to IL487 or IL418 for system wiring details)

Note: This configuration should only be used when the PK601A Power Supply is located in close proximity to the LI404B Strobe.

In a typical LI404B Strobe add-on installation, the LI404B Strobe receives power from the local PK601A Power Supply terminals F (+24 VDC) and D (Return).

The LI404B Strobe trigger (buzz) is typically sourced by the same tone line that feeds the remote station (X terminal). This tone signal is approximately +24 V pulsed to ground at a 1 KHz rate.

Pressing the respective call button at the entrance panel results in a tone to the apartment and trigger to the strobe.

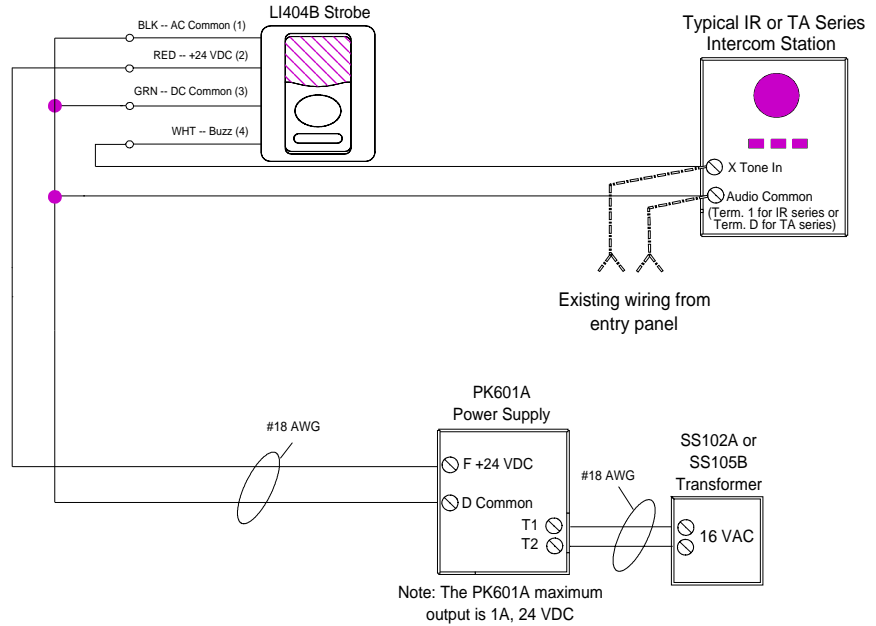

LI404B Wiring Diagram for PK543A Systems

(Refer to IL826 for system wiring details)

In a typical PK543A installation, the LI404B Strobe receives power from the PK543A Amplifier's terminals P (+24 VDC) and K (Return), or from a local 24 VDC power supply when strobes are

being installed as an add-on to the intercom system. (Use terminals V and K with a PK543.) The PK543A Amplifier can power up to two strobes per apartment. When more than two strobes

per apartment are used, a PK601A Power Supply must be used in conjunction with the PK543A Amplifier to supply power to the strobes.

The LI404B Strobe trigger (buzz) is typically sourced by the same tone line that feeds the remote station (X terminal). This tone signal is approximately +24 V pulsed to ground at a 1 KHz rate. For the strobe, the return for this tone line is the PK543A terminal K.

Note: The strobe return differs from the station return, which is the "1" terminal on the station and the "1" terminal on the PK543A. The importance of the alternate strobe return is to prevent audio distortion during strobe activity.

Pressing the respective call button at the entrance panel results in a tone to the apartment and trigger to the strobe.

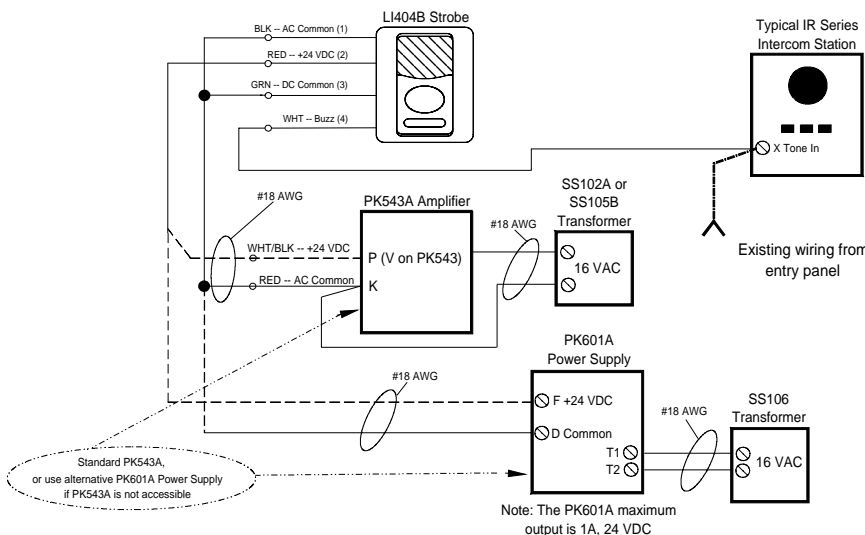

LI404B Wiring Diagram for PK205 Systems

(Refer to IL418 for system wiring details)

In a typical PK205 installation, the LI404B Strobe receives power from the PK601A Power Supply terminals F (+24 VDC) and D (Return).

The LI404B Strobe trigger (buzz) is typically sourced by the same tone line that feeds the remote station (X terminal). This tone signal is approximately +24 V pulsed to ground at a 1 KHz rate. For the strobe, the return for this tone line is the PK205 terminal K.

Note: The strobe return differs from the station return, which is the "D" terminal on the station and the "D" terminal on the PK205. The importance of the alternate strobe return is to prevent audio distortion during strobe activity.

Pressing the respective call button at the entrance panel results in a tone to the apartment and trigger to the strobe.

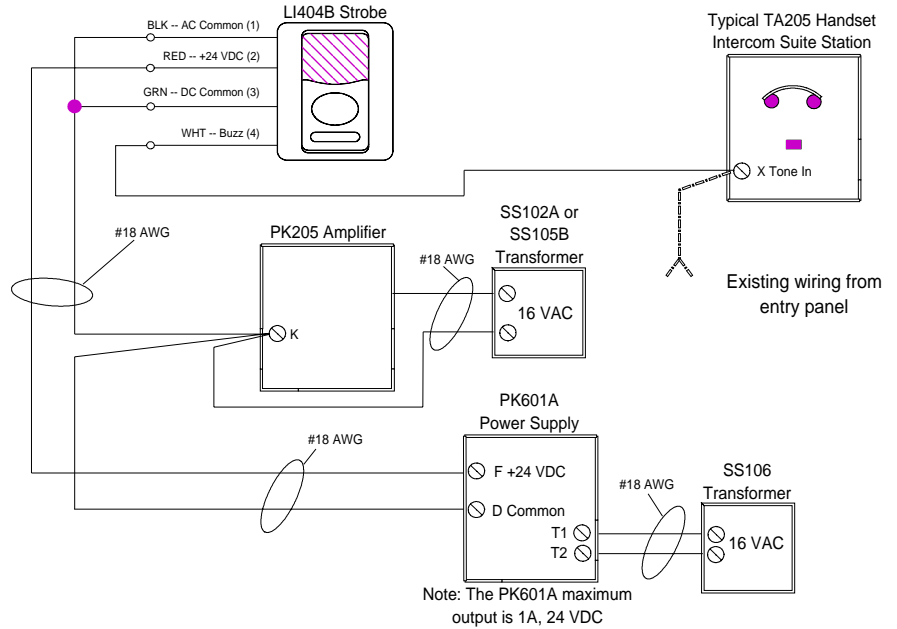

LI404B Wiring Diagram for PK104B Systems

(Refer to IL468 for system wiring details)

In a typical PK104B installation, the LI404B Strobe receives power from the PK601A Power Supply terminals F (+24 VDC) and D (Return).

The LI404B Strobe trigger (buzz) is typically sourced by the same tone line that feeds the remote station (X terminal). This tone signal is approximately +24 V pulsed to ground at a 1 KHz rate. For the strobe, the return for this tone line is the PK104B terminal K.

Note: The strobe return differs from the station return, which is the "1" terminal on the station and the "1" terminal on the PK104B. The importance of the alternate strobe return is to prevent audio distortion during strobe activity.

Pressing the respective call button at the entrance panel results in a tone to the apartment and trigger to the strobe.

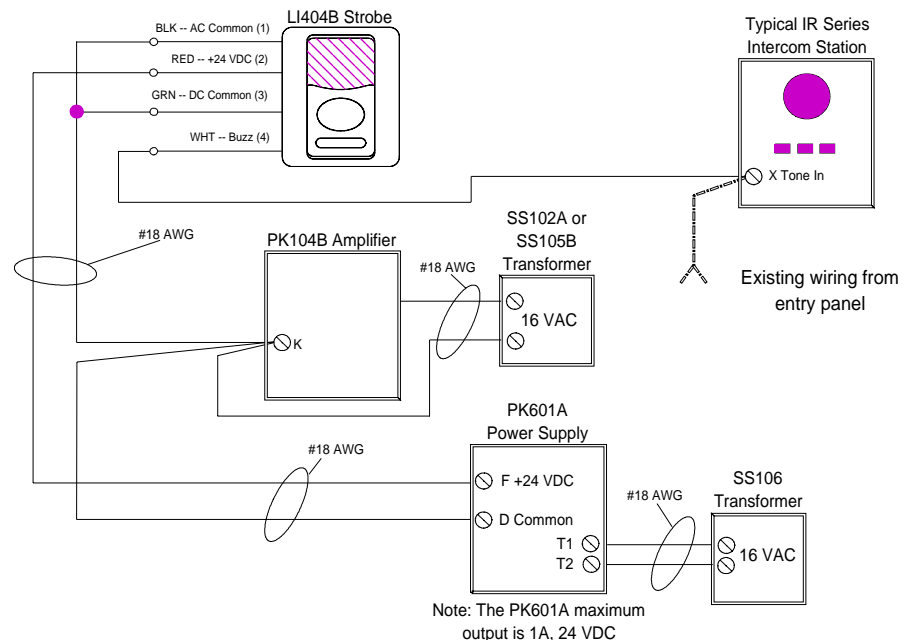

LI404B Stand-Alone Wiring Diagram with pushbutton activation

In a typical LI404B Strobe stand-alone installation, the LI404B Strobe requires a +24VDC power source, as indicated on the wiring diagram. The +24VDC power source must have a minimum of 250ma current capability. For each additional strobe unit to be activated simultaneously, increase the supply's current capability by 200ma.

