



*Communications
for today... and tomorrow*

IL835
SECTION E
Rev. 4 - 05/2012

Tek-MMARS®II NC386B
Management Monitoring And Reporting System
for use with the Tek-CARE®NC300 & NC300II Nurse Call Systems

Operation, Installation and Service Manual

Distributed by:



Alpha Communications®
42 Central Drive
Farmingdale, NY 11735-1202
Phone: (631) 777-5500
Fax: (631) 777-5599

Website:
www.AlphaCommunications.com

Email:
info@alphacommunications.com

TOLL-FREE Technical #:
1-800-666-4800

Tek-MMARS®II NC386B is a totally integrated real time **Management, Monitoring And Reporting System** that may be added to TekTone®'s Tek-CARE®NC300 & NC300II microprocessor-controlled nurse call systems. Total system capacity is 8 central equipment units.

Operation, Installation and Service Manual

Copyright © 2001–2012 TekTone® Sound & Signal Mfg., Inc., All rights reserved.

No part of this publication may be copied without the express written permission of TekTone® Sound & Signal Mfg., Inc. The content of this manual is furnished for informational use only, is subject to change without notice, and should not be construed as a commitment by TekTone® Sound & Signal Mfg., Inc. TekTone® Sound & Signal Mfg., Inc. assumes no responsibility or liability for any errors or inaccuracies that may appear in this documentation.

TekTone, the TekTone logo, Tek-Alert, Tek-Call, Tek-Care, Tek-Check-In, Tek-Com, Tek-Digicare, Tek-Door, Tek-Entry III, Tek-Guard, Tek-Micro, Tek-Micro II, Tek-MMARS II, TekNIOS, TekNIOS II, Tek-Paging, Tek-Phone, Tek-Safe, Tek-Select II, Tek-Sentry, Tek-Sound, Tek-Status, Tek-Trio and Tek-View are either registered trademarks or trademarks of TekTone® Sound & Signal Mfg., Inc. in the United States and/or other countries. All other trademarks are the property of their respective owners.

Table of Contents

A Word about ESD (Electrostatic Discharge)	iv
System Introduction	1
System Operating Instructions	2
Starting Reporting	2
Tek-MMARS®II Report Options	2
Accessing Tek-MMARS®II Reports via an Internal Network Connection	3
System Installation	5
Equipment Descriptions, Locations and Connections	5
Tek-MMARS®II Configuration and Settings	5
System Menu	5
Paging Menu	9
Reporting Menu	10
Database Menu	12
Security Menu	12
Help Menu	12
System Database Repair Instructions	13
System Test Instructions	14
Illustrations	
Figure 1—Tek-MMARS®II Main Window	3
Figure 2—Welcome Screen	3
Figure 3—Report Options	4
Figure 4—Cable Wiring Diagram	6
Figure 5—Pager Wiring Diagram	6
Figure 6—System Menu: General Setup	6
Figure 7—System Menu: Call Type Setup	6
Figure 8—System Menu: Shift Setup	6
Figure 9—System Menu: System Names	8
Figure 10—System Menu: Printable Setup	8
Figure 11—Paging Menu: Paging System Setup	8
Figure 12—Paging Menu: Pager Assignments	8
Figure 13—Paging Menu: Custom Page	11
Figure 14—Database Menu: Backup	11
Figure 15—Database Menu: Purge Events	11
Figure 16—Database Menu: Import 2.5 Series Database	11
Figure 17—Security Menu: Set Password	11
Figure 18—Security Menu: Unlock	11
Figure 19—Help Menu: About Tek-MMARS II	11
Figure 20—Database Repair	13
Figure 21—Restore Database	13
Figure 22—New Database	13
Figure 23—Tek-MMARS®II Test Worksheet	15

A Word about ESD (Electrostatic Discharge)

What Is It? Static electricity is a result of triboelectric charging of two dissimilar nonconductive materials that are rubbed together, such as rubbing your feet on a carpet on a cold winter day or in a dry climate. The resulting charge is detected when you reach out to touch a doorknob or some other metallic object. The resulting discharge may only be startling or, in severe cases, it may even be painful. The actual electrical charge is dependant on the materials being rubbed together, humidity, the rate of separation, and other factors.

What Can It Do? While this effect may be disturbing to humans, the effect on electronic equipment is often more serious, ranging from operational disruption to actual component damage. These effects result from the high voltages that may be developed. The simple act of walking across a carpet may develop as much as 30,000 volts, and changing a bed sheet may create a charge of 100,000 volts or more. Such voltages readily cause arcing (the spark that can be observed when you grab a doorknob after walking across a carpet, etc.). The arcing is evidence of the discharge path. Due to the high voltage involved, the discharge current can jump to any nearby metallic or non-metallic object. If the discharge is to or through an electronic device, such as the nurse call system, the operation of the device may be affected. If the discharge current passes through internal components, these components may be damaged or their operation degraded.

What Can We Do About It? The manufacturer of the nurse call equipment has already taken steps to protect the equipment from electrostatic discharge (ESD) effects. Our peripheral equipment has been tested and listed by UL® to withstand discharges of up to 30K volts. However, since the cause is not in the equipment, but in the environment, further measures are required of the installer and the user to achieve complete protection.

What The Installer Can Do: In humid climates or in places where the relative humidity is kept at 65% or greater, there will likely be few problems with ESD. Where problems may occur the following measures can be taken.

- Ground all exposed metal surfaces. Grounding should be to a #16 gauge or larger conductor.
- Install nurse call system wiring in metal conduit. This conduit may be used to ground panels.
- Use shielded cable (where specified) for nurse call system station-to-station wiring. The use of open conductors invites inductive coupling of discharge currents, which can cause the same problems as direct discharge currents.
- Ground your body before handling system components. This can be done by using a wrist strap, or simply by contacting a grounded metal surface. Use caution to avoid hazardous voltages while grounded.

What The User Can Do: The most common generation of ESD in hospitals is due to changing linen on hospital beds while the patient call cord or pillow speaker is still connected to the nurse call system. The following precautions will help.

Remove the call cord or pillow speaker from the bed before changing the linen. It will be necessary for the nursing staff to discharge themselves by contacting a grounded metal object before placing the call cord or pillow speaker back on the bed; otherwise a spark will jump to the nurse call equipment, causing the very damage they are trying to avoid. To avoid a shock while discharging static electricity on the body, hold a metal object, such as a key, and use that object to contact the grounded surface.

This information is provided to make you aware of ESD problems so that precautions may be taken to avoid damage and disruption of system operation.

System Introduction

Tek-MMARS®II is a Management, Monitoring and Reporting System designed to work with the microprocessor-based Tek-CARE®NC300 & NC300II nurse call systems. Tek-MMARS®II provides the following functions.

Management and Reports:

Tek-MMARS®II monitors and stores patient and staff activity. All nurse call system activity is saved on a hard drive, and the information can be retrieved via the Tek-MMARS®II Reporting System, as further described later in this manual.

Monitoring:

Tek-MMARS®II provides real time monitoring of all nurse call activity from up to a total of 8 NC350C series and/or NC351A series Central Equipment (CE) units (with PCI Card). The monitoring feature also provides call-type filtering. If the “code calls only” option is selected, only code calls will appear on the Tek-MMARS®II screen.

Radio Pocket Paging:

With the addition of an NC369 Paging Transmitter, pages can be sent automatically or semi-automatically to NC390-series Alphanumeric Pagers. Paging can be centrally located for multiple nurse call systems using the Tek-MMARS®II System.

Event Printing:

In addition to providing report printouts, Tek-MMARS®II also provides event printouts.

Restoring/Backing Up:

Tek-MMARS®II can backup and restore event files. This gives the user the ability to create a permanent history record on disk, and to later restore that information to create reports from those files.

System Operating Instructions

Tek-MMARS®II, a Microsoft® Windows®-based system, produces standard reporting that provides valuable information to evaluate and optimize staff time. The information contained in these reports also provides accountability information to the facility for each zone, room, type of call and time period. If no parameters are chosen, the report will automatically include all floors, zones, rooms and calls since the last archive. Report headings list all parameters chosen for that report.

General MS Windows® Terms

Point: Move the mouse until the arrow on the screen points to the desired location.

Click: Press and release the left mouse button.

Drag: Move the mouse while holding the left mouse button down.

Button: A grey rectangular box on the screen with text or pictures that explain its purpose. A button is used to cause an action.

Radio Button: A series of circles that have text to the right. One radio button will have a large black dot in it, and the others will be empty. The dot indicates which button has been selected. Only one radio button in a series may be chosen at a time.

Check Box: A series of small square boxes that have text to the right. Each box will either be empty or will have a check mark in it. Each time a box is selected, it toggles between on (check mark) and off (empty). More than one check box in a series may be chosen at a time.

Selecting a Button

Use the mouse to position the arrow over the button, and then click on it; or press the **TAB** key on the keyboard to cycle through the buttons until the desired button is highlighted, and then press the **ENTER** key.

Selecting a Radio Button

Use the mouse to position the arrow over the radio button, and then click on it; or press the **TAB** key on the keyboard until the desired radio button has a large dot in it, and then press the **ENTER** key.

Selecting Check Boxes

Use the mouse to position the arrow over the check box, and then click on it; or press the **TAB** key on the keyboard to cycle through the check boxes until the desired check box is selected, and then press the **SPACEBAR** to toggle it on or off.

Starting Reporting

To start the reports program, select the Reporting menu at the top of the Main Window (see [Figure 1](#)) and then select Launch Reporting. The Tek-MMARS®II welcome screen will appear. (See [Figure 2](#).) Click the **CREATE REPORT** button.

Tek-MMARS®II Report Options

This screen is used to define the report's parameters. (See [Figure 3](#).) Select or enter the desired report Time and Date, Relevant Calls (Event Types, Systems, Zones, Rooms, Patients/Labels), and Report Visualizations (Grouping, Summary, Details, Descriptions). Uncheck **ALL** before making changes to the selections. Hold down the **CTRL** key to make multiple selections or to unselect a single selection from a list. Always use 24-hour time.

After choosing desired report options, click on the **CREATE REPORT** button at the bottom of the screen.

Accessing Tek-MMARS®II Reports via an Internal Network Connection

If the Tek-MMARS®II system is connected to an internal network, Tek-MMARS®II reports may be accessed from another computer connected to the same network.

To Launch Reporting from another computer, open Microsoft® Internet Explorer and type “*http://IP address/TekMMARSII_reporting/welcome.php*” in the address line. (Contact your network’s administrator to obtain the *IP address* of your Tek-MMARS®II system.) Once this link has been established, create a Windows shortcut or an Internet Explorer favorite for easy access in the future.

Figure 1—Tek-MMARS®II Main Window

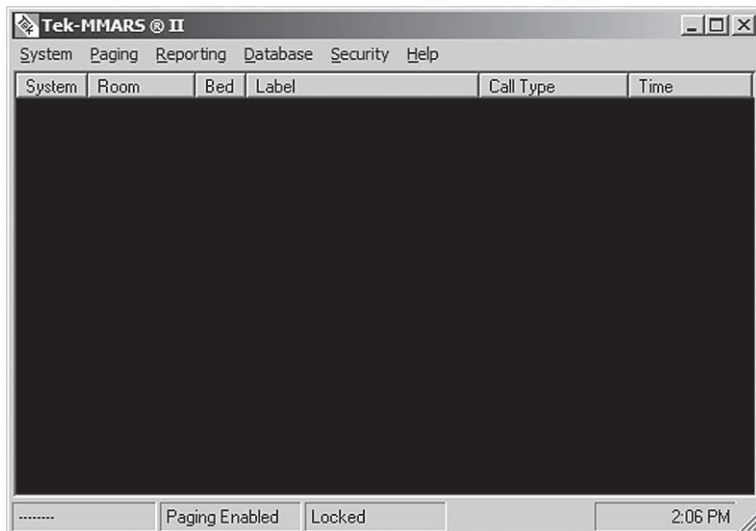

Figure 2—Welcome Screen

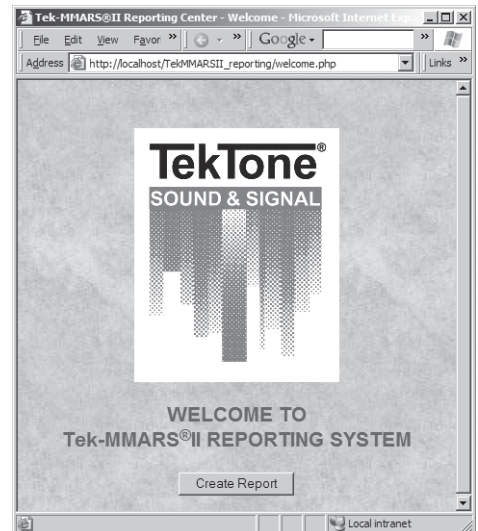

Figure 3—Report Options

Tek-MMARS®II Reporting Center - Report Options - Microsoft Internet Explorer

Address http://localhost/TekMMARSII_reporting/reporting.php

Tek-MMARS®II Report Options

There are 48651 events in the database.

Time and Date

Start Date: / / :
End Date: / / :
MM / DD / YYYY HH : mm

All

Shifts:
FIRST
SECOND
THIRD

All

Relevant Calls

Event Types: AIDE AIDE REQ BATH CODE CORD OUT DUTY EMERGENCY FIRE MONITOR NURSE <input checked="" type="checkbox"/> All	Systems: SYSTEM 1 SYSTEM 8 <input checked="" type="checkbox"/> All	Zones: A B C D E F G H I J <input checked="" type="checkbox"/> All	Rooms: 813 821 8100 8103 8106 8109 8112 8115 8118 8119 <input checked="" type="checkbox"/> All	Patients/Labels: ACTIVITY ROOM BACK DOOR BACK INTERCOM BATH HALL 1 BATH HALL 2 BK DR INTERCOM BREAK ROOM CEN BATH 1 CENTRAL BATH 1 <input checked="" type="checkbox"/> All
---	--	--	--	---

Response Time:
 Only with response times over : (mm:ss).

Report Visualization

Report Description (optional):

Show Summary
 Not Grouped Grouped by Hour Grouped by Room

Show Details

General Tips:

Uncheck 'All' before trying to make changes in selection boxes.
Hold CTRL to select or deselect a single object from a list.
Always use 24 hour time.

Done Local intranet

System Installation

Read the following instructions concerning system equipment, and determine installation methods before proceeding.

- Determine equipment locations.
- Install wiring.
- Check wires for shorts and grounds.
- Complete installation of nurse call system.
- Connect Tek-MMARS®II to nurse call system.
- Check connections.
- Configure Tek-MMARS®II System.
- Test Tek-MMARS®II System.
- Train system operators.

System Requirements:

- Tek-CARE®NC300 or NC300II nurse call system.
- Tek-MMARS®II (NC386B) Management Monitoring And Reporting System.

Equipment Descriptions, Locations and Connections

Tek-CARE®NC300 & NC300II Nurse Call Systems

For details on the installation and setup for these systems, refer to the nurse call system's installation manual.

NC386B System

The NC386B should be located where best suited for each facility's requirements.

Tek-CARE®NC300 & NC300II to NC386B Interconnection

See [Figure 4](#) for location of ports. Cables must be wired as shown in [Figure 4](#). The maximum wire distance is 100'.

Parallel Printer

The supplied parallel printer plugs into the parallel printer port (Female 25-pin) on the back of the Tek-MMARS®II.

Pager System (optional)

Compatible pager systems are Scope® and Motorola® Comp II. See [Figure 5](#) for port connection.

Tek-MMARS®II Configuration and Settings

Depending upon the chosen settings, the Main Window will show all active calls, only calls of selected types, or no calls. System default is to display all calls. See the Main Window in [Figure 1](#).

The menus listed across the top of the screen allow a facility to customize the Tek-MMARS®II system's configuration. The menus are: System, Paging, Reporting, Database, Security and Help. Most menu option windows include a ? (**help**) button, which displays the relevant section of this manual in web page format.

System Menu

General Setup (Figure 6)

Display Calls—This option allows the main call display to be turned on or off. Calls are displayed when a check mark appears next to *Display Calls*.

Figure 4—Cable Wiring Diagram

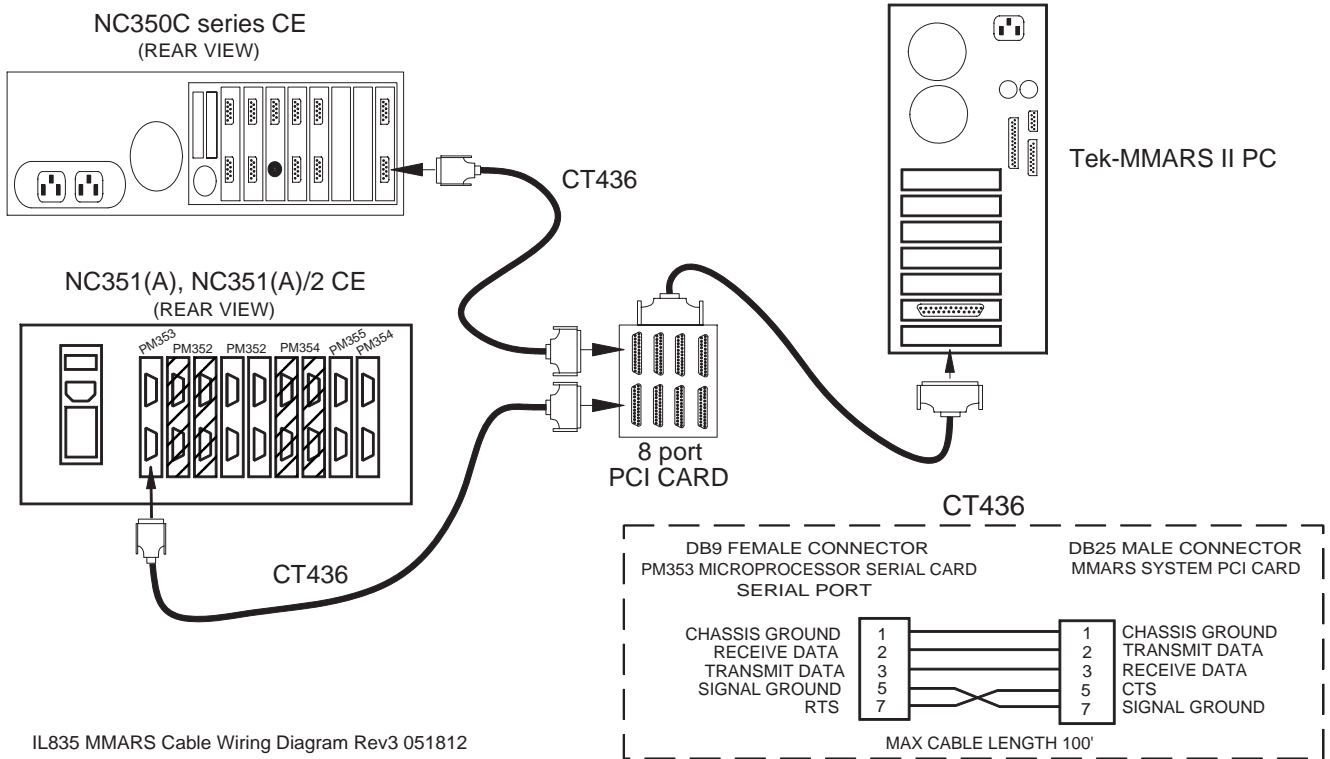

IL835 MMARS Cable Wiring Diagram Rev3 051812

Figure 5—Pager Wiring Diagram

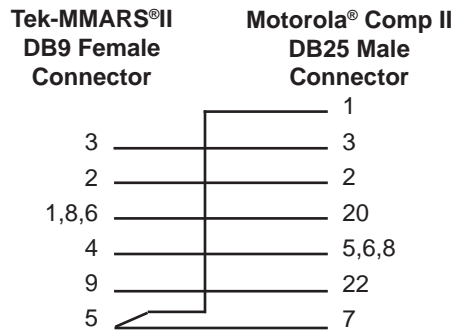
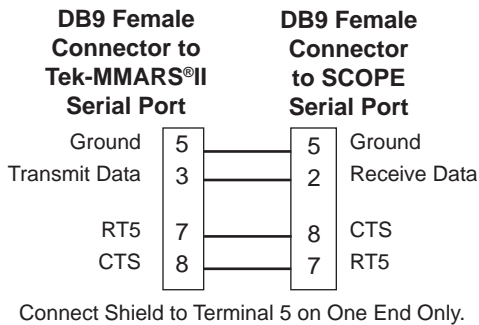

**Figure 6—
System Menu:
General Setup**

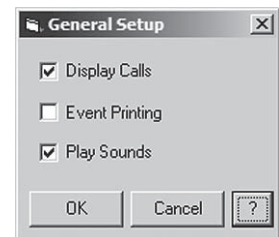

Figure 7—System Menu: Call Type Setup

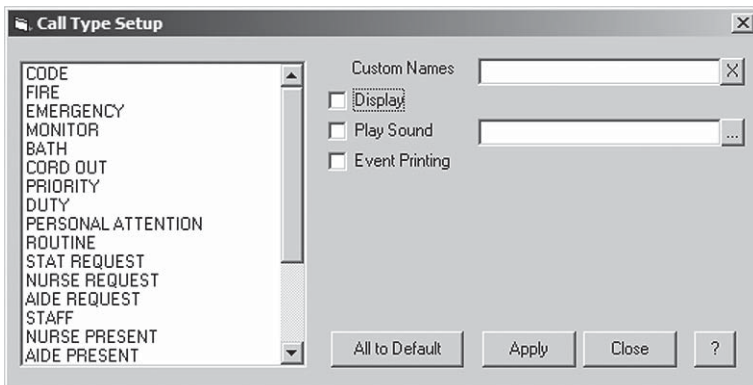
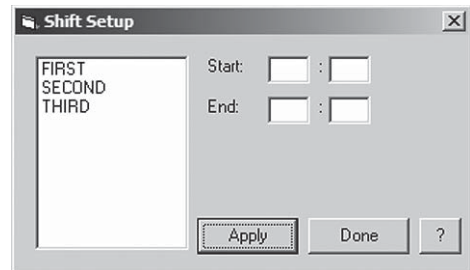

Figure 8—System Menu: Shift Setup



Event Printing—This option allows event printing of calls to be turned on or off. (Factory default is off. *Event Printing* must be off except while an event printer is connected.) Calls are printed when a check mark appears next to *Event Printing*. (Individual call types are selected in *System Menu—Call Type Setup*.)

Play Sounds—This option allows the main Audio Alerts to be turned on or off. Audio Alerts for calls are played when a check mark appears next to *Play Sounds*.

Call Type Setup (Figure 7)

Call Type—Select an individual call type to set up.

Custom Names—Give the selected call type a custom name (available only with Tek-CARE®NC300II nurse call systems). This option is used only if the Tek-CARE®NC300II system has been programmed with custom call type labels. Select a call type and click in the *Custom Names* box. Then enter the custom name used for that call type by the Tek-CARE®NC300II system. (The Tek-MMARS®II custom names and Tek-CARE®NC300II call type labels must be the same for each call type.) If multiple custom names are required, enter them separated by commas (example: BLUE, PINK, NOW). Click on the **APPLY** button to implement and save the settings. Tek-MMARS®II system will then display calls using the same custom names used by the Tek-CARE®NC300II system.

Play Sound—Select whether audio alerts are played for the selected call type and which sound is played. Place a check mark in the box next to *Play Sound* and click on the button beside the text box to select which WAV file plays when that call type is placed. Click on the **APPLY** button to implement and save the settings. (*Play Sound* settings are preconfigured at the factory to play various WAV files located in the **C:\TekMMARSII\Sounds** directory, but other WAV files may be used, if desired.)

Event Printing—Select whether the selected call type is printed on the event printer. Place a check mark in the box next to *Event Printing* and Click on the **APPLY** button to implement and save the settings. (*Event Printing* must also be checked in *System—General Setup*.)

All to Default button—Click on this button to reset all call types to the default settings, as follows:

Custom Names:	Blank
Display:	Checked
Play Sound:	Checked
Event Printing:	Checked

Shift Setup (Figure 8)

This option is used to set up the shift times for Reporting and Pagers. Select first, second or third shift, and then enter the start and end times for that shift. Click on the **APPLY** button to implement and save the settings for that shift.

System Names (Figure 9)

This option is used to create custom names for each Tek-CARE®NC300 & NC300II system used on the Tek-MMARS®II system. These custom names will be displayed in the Reports. Double-click on a default system name and enter a new custom name. Click **OK** twice.

Printable Setup (Figure 10)

This option allows the General Setup and Call Type Setup settings to be viewed all at once. This file may be saved or printed by selecting the File Menu in the *System_Setup.txt - Notepad* screen being displayed.

Exit

This option closes the Tek-MMARS®II program.

Figure 9—System Menu: System Names

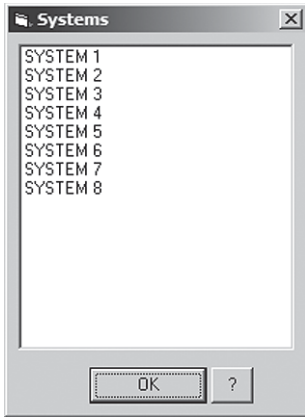

Figure 10—System Menu: Printable Setup

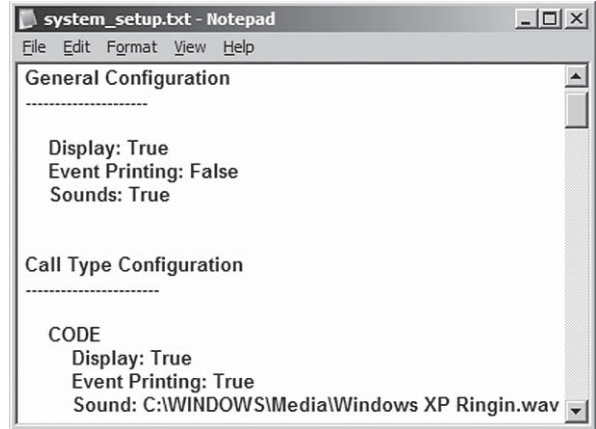

Figure 11—Paging Menu: Paging System Setup

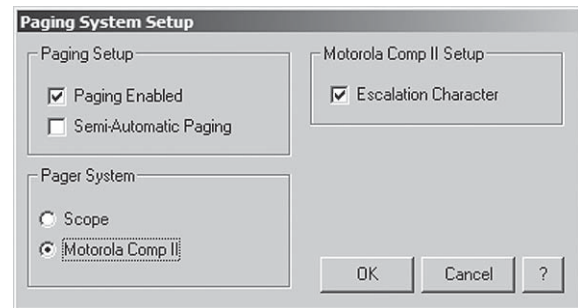
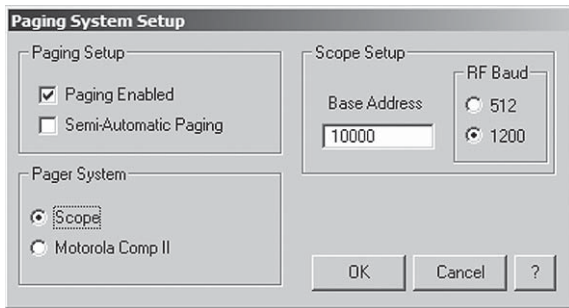
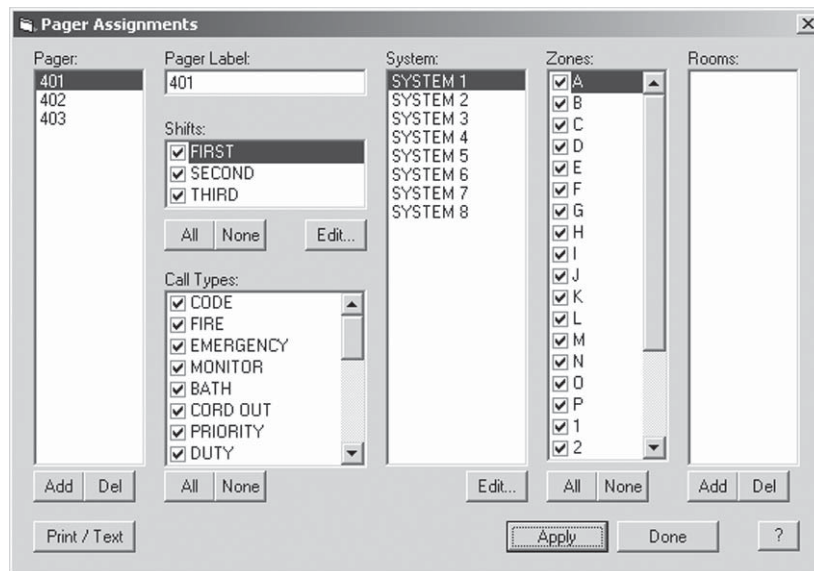

Figure 12—Paging Menu: Pager Assignments



Paging Menu

Paging Setup (Figure 11)

Paging Setup—These options prepare the pager system for input from Tek-MMARS®II.

Place a check mark in the box beside Paging Enabled to allow assigned pagers to receive pages when calls are placed, and then click the **OK** button. “Paging Enabled” or “Paging Disabled” is displayed at the bottom of the Main Window (Figure 1).

If Semi-Automatic Paging is selected, when a call is placed a window pops up and asks whether to send the page or cancel the page for each pager assigned to that call. If neither choice is selected within 15 seconds, the page is sent automatically. Place a check mark in the box beside Semi-Automatic Paging to enable this feature, and then click the **OK** button.

Pager System—Use this option to select the type of Pager System being used—Scope (when using TekTone® NC366A/T Paging Transmitter) or Motorola Comp II (when using TekTone® NC369 or NC365A/T Paging Transmitter). Click on the desired system type and click **OK**.

Scope Setup—These options are available when Scope is selected as the Pager System type. Factory default Base Address is 10000 and default RF Baud is 1200. (See *IL671 Installation Instructions for NC365/A/AT, NC366A/AT, NC368A/AT* for more information about paging system settings.)

Motorola Comp II Setup—This option is available when Motorola Comp II is selected as the Pager System type. Check the Escalation Character option—it allows character escalation to be sent by Motorola Comp II systems. (See *IL888 NC369 Paging Transmitter Installation Instructions* for more information about paging system settings.)

Pager Assignments (Figure 12)

Pager—This option is used to add, delete and set up pagers. To add a pager, click on the **ADD** button, enter the pager’s cap code, and press the **OK** button. To delete a pager, select the pager to be removed and click on the **DEL** button.

Pager Label—This is a custom name that is displayed when using the Pager Assignments Print/Text option. Enter the custom name to apply to the selected pager and click the **APPLY** button to save.

Shifts—Check off the shift(s) to assign to the selected pager. Click on the **ALL** button to assign all shifts, or the **NONE** button to assign no shifts. Click the **EDIT** button to change the shift times. (If the shift times are changed here, they are changed for all Tek-MMARS®II operations.) Click on the **APPLY** button to save the new settings.

Call Types—Check off the call types the selected pager will respond to. Click on the **ALL** button to assign all call types, or the **NONE** button to assign no call types. Click on the **APPLY** button to save the new settings.

System—Each pager receives pages from all Tek-CARE®NC300 & NC300II nurse call systems connected to the Tek-MMARS®II system, according to the zones and/or rooms assigned to that pager by Tek-MMARS®II. (See *Zones* and *Rooms* below to assign zones and/or rooms to a pager.) Use the **EDIT** button to give a custom name to each Tek-CARE®NC300 & NC300II system used with the Tek-MMARS®II system. This custom name is displayed in the *Reports and Pager Assignments* printout. Double-click on a system, enter a custom name, and click **OK**. (If custom system names are changed here, they are changed for all Tek-MMARS®II operations.) Click on the **APPLY** button to save the new settings.

Zones—Select a pager and a system, and then check off the call zones the selected pager will respond to for that system. Click on the **ALL** button to assign all zones, or the **NONE** button to assign no zones. Click on the **APPLY** button to save the new settings. Repeat for each pager/system combination.

Rooms—This option allows individual rooms to be assigned to the selected pager. Select a pager and a system, click the room **ADD** button, type in the room number to assign, and click **OK**. Multiple rooms on multiple systems may be assigned to a single pager. Select a room and click **DEL** to remove an assigned room from the selected pager. Click on the **APPLY** button to save the new settings. (Example: If pager 401 is assigned to all zones on system #1 and no zones on the other systems, pager 401 will only respond to rooms on system #1. If pager 303 is assigned to no zones and room #2001 on system #1, and to all zones on system #2, pager 303 will respond to all rooms on system #2, but only room #2001 on system #1.)

Print/Text button—Click the **PRINT/TEXT** button to view and/or print all pager assignments. This form may be saved or printed for future use by selecting the File Menu in the *paging_setup.txt - Notepad* screen displayed.

Custom Page (*Figure 13*)

Select this option to send a custom page to one or more pagers in the Tek-MMARS®II system. Check off the pagers that will receive this message, select an escalation level, and type a message in the *Message* box. Then click the **SEND** button to send the custom message to the selected pagers.

Reporting Menu

Launch Reporting

Starts the Tek-MMARS®II Reporting System. See *System Operating Instructions—Tek-MMARS®II Report Options* for more details.

Reporting Help

This option displays this manual in web page format, beginning at the *System Operating Instructions—Starting Reporting* section.

Figure 13—Paging Menu: Custom Page

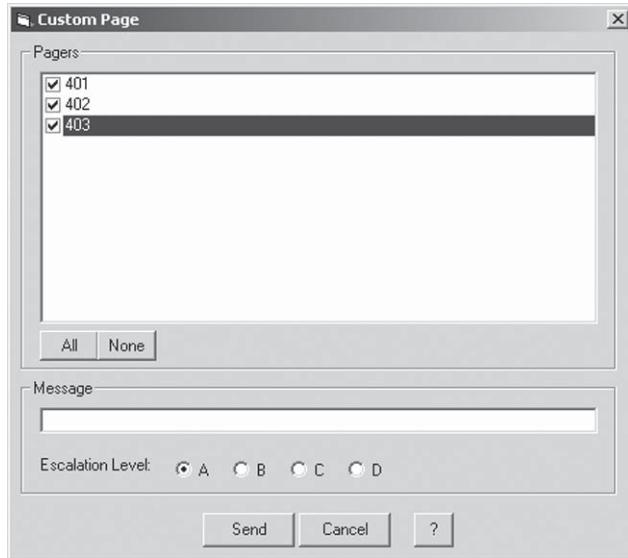

Figure 14—Database Menu: Backup

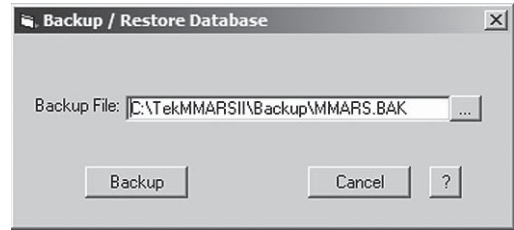

Figure 15—Database Menu: Purge Events

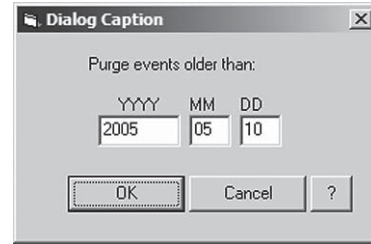

Figure 16—Database Menu: Import 2.5 Series Database

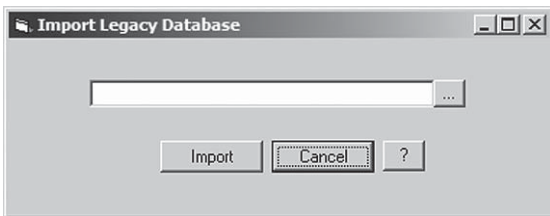

Figure 17—Security Menu: Set Password

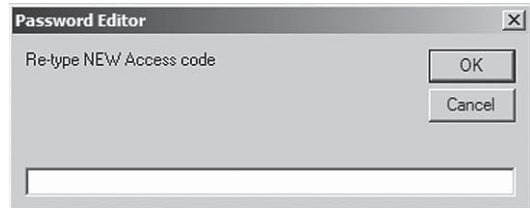
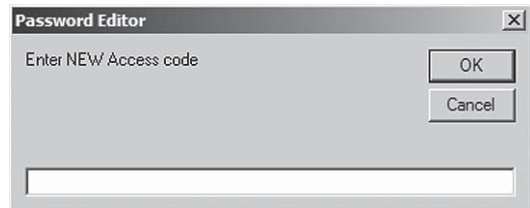

Figure 18—Security Menu: Unlock

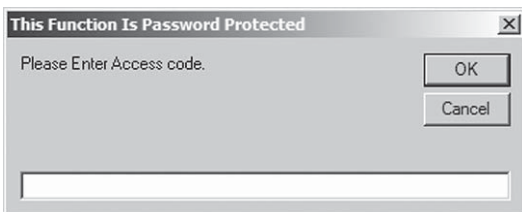
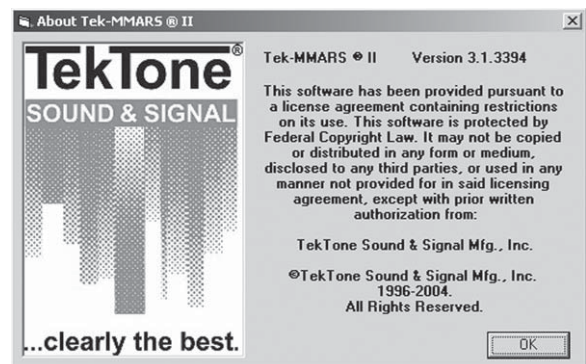

Figure 19—Help Menu: About Tek-MMARS II



Database Menu

Backup (Figure 14)

This option saves the current database and settings on the computer's hard drive so that it can be backed up to a CD-R disk or another external device. Select Backup in the Database menu and type the desired path and filename to save the backup file. The default path/filename is *C:\TekMMARSII\Backup\MMARS.BAK*. After the database is saved to the hard drive, copy the file to a CD-R disk using CD burner on the Tek-MMARS®II system.

Purge Events (Figure 15)

This option purges all events older than the specified date, while keeping the current system settings. Select Purge Events in the Database menu, enter the date before which all events will be purged, and click **OK**. **WARNING: If a database backup is not performed prior to performing Purge Events, all events prior to the purge date will be lost.**

Import 2.5 Series Database (Figure 16)

This option allows older Tek-MMARS®II system databases to be imported into the current Tek-MMARS®II system. Select Import Legacy Database in the Database menu, enter the file path of the database to be imported, and click the **IMPORT** button.

Security Menu

Default Password

The default password (as shipped from the factory) is **tektone** (lowercase).

Set Password (Figure 17)

Sets the Security Password for the Tek-MMARS®II system. Select Set Password in the Security Menu, enter the new access code (password), and click **OK**. Then re-type the new access code (password) and click **OK**.

Lock

When Lock is selected in the Security menu, all functions except System Printable Setup and Custom Paging are accessible only after typing the assigned access code (password). "Locked" or "Unlocked" is displayed at the bottom of the Main Window (Figure 1).

Unlock (Figure 18)

When Unlock is selected in the Security menu, no access code (password) is required to access any Tek-MMARS®II function.

Security Help

This option displays this manual in web page format, beginning at the *System Installation—Security Menu* section.

Help Menu

Help—F1

This option displays this manual in web page format. The web page help file also gives the option of viewing and/or printing a PDF version of this manual.

About Tek-MMARS II (Figure 19)

Displays the Tek-MMARS®II version number, rights, restrictions and program information.

System Database Repair Instructions

The Database Repair Functions are used to restore a backup of the Tek-MMARS®II database or to create a completely new blank database.

WARNING: If a database backup is not performed prior to performing Restore Database or New Database, all events and settings in the current database will be lost.

Restore Database (Figure 20, Figure 21)

To restore a previously saved or backed up database, close the Tek-MMARS®II program, and double-click on the *Tek-MMARSII Database Repair* Icon on the Windows Desktop. Next, click on the **RESTORE** button, enter the path and filename of the database to be restored, click **OK**, and then click the **CLOSE** button.

New Database (Figure 20, Figure 22)

To create a new blank database, close the Tek-MMARS®II program and double-click on the *Tek-MMARSII Database Repair* Icon on the Windows Desktop. Next, click on the **NEW DATABASE** button, click the **YES** button, and then click the **CLOSE** button.

Figure 20—Database Repair

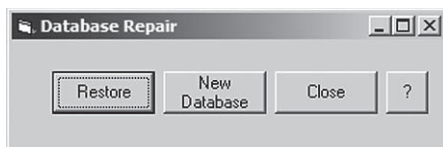

Figure 21—Restore Database

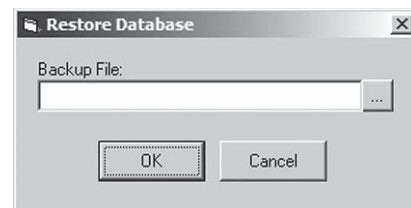
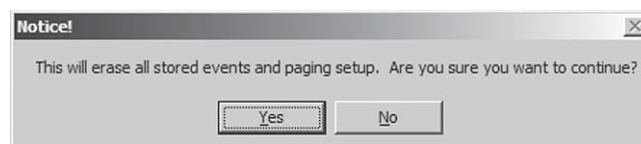

Figure 22—New Database



System Test Instructions

Start System

1. Ensure all affiliated Tek-CARE®NC300 & NC300II systems are active and connected according to the wiring diagram in [Figure 4](#).
2. Turn on the Tek-MMARS®II computer.
3. Turn on the printer (if connected).

After Windows XP finishes loading on the Tek-MMARS®II computer, double-click on the *Tek-MMARS II* icon on the Windows Desktop. Click **OK** in the window that appears, and then the Tek-MMARS®II system will begin running (see the Main Window in [Figure 1](#)). If the system numbers are shown in the bottom left of the Main Window, the corresponding Tek-CARE®NC300 & NC300II systems are connected properly and running. If any systems are not shown, check those systems' connections to Tek-MMARS®II.

Testing the Tek-MMARS®II System

Using the Tek-MMARS®II Test Worksheet (see [Figure 23](#)), check valid call types for your connected Tek-CARE®NC300 & NC300II systems. Initiate calls from each Tek-CARE®NC300 & NC300II system to ensure the call is displayed on the Tek-MMARS®II screen. For example:

1. Place a routine call from a Tek-CARE®NC300 or NC300II system.
2. If Display Calls is checked in the General Setup options (see *System Installation—System Menu—General Setup—Display Calls*) and Display is checked for the Routine call type (see *System Installation—System Menu—Call Type Setup*), then “Routine Call” should appear on the Tek-MMARS®II.
3. If Event Printing is checked in the General Setup options (see *System Installation—System Menu—General Setup—Display Calls*) and Event Printing is checked for the Routine call type (see *System Installation—System Menu—Call Type Setup*), then “Routine Call” should be printed on the event printer.
4. If pagers are set up on the system (see *System Installation—Paging Menu*), the appropriate pager should beep and display “Room #: 8101-1 Routine Call.”
5. Cancel the routine call on the Tek-CARE®NC300 or NC300II system.
6. “Routine Call” should disappear from the Tek-MMARS®II screen.
7. The event printer should print “Routine Call End.”
8. The appropriate pager will continue to beep and display until it is cleared or reset. Pages may only be reset or cleared at the pager.

Repeat steps 1–8 for all valid Call Types that were selected on the Tek-MMARS®II Test Worksheet (see [Figure 23](#)).

Testing the Tek-MMARS®II Reports

After testing all valid Call Types for each Tek-CARE®NC300 & NC300II system, view the various reports (see *System Operating Instructions—Starting Reporting*) to verify that all data has been collected in the Tek-MMARS®II database.

Figure 23—Tek-MMARS®II Test Worksheet

Test Date: _____

Valid Call Types for Tek-CARE® NC300 & NC300II Systems								
Event	1	2	3	4	5	6	7	8
Routine Call								
Pers. Attn. Call								
Priority Call								
Bath Call								
Emergency Call								
Fire Call								
Monitor Call								
Code Call								
Staff Call								
Duty Call								
Aide Requested								
Aide In								
Nurse Requested								
Nurse In								
Stat Requested								