



NH201TVA or NH201TT Amplifier and Power Supply Installation and Use Instructions Used with the HT3001 and/or HT2001 Series Inside Handset Intercom Stations

APPLICATION

The NH201TVA (and NH201TT) series intercom system allows one or more HT3001 and/or HT2001 series inside handset stations to communicate with one or more door entry stations, and to release the door opener at each door entry station. A number of optional accessories are available to provide a complete entry intercom signaling and communications system.

PROCEDURE

1. Read installation instructions for each unit to determine equipment location and installation method.
2. Install housings and wiring.
3. Install equipment.
4. Check wiring and connect. Observe all local electrical codes.
5. Apply power and check operation.

HOUSING INSTALLATION AND EQUIPMENT LOCATION

INSIDE HANDSET STATIONS

Locate stations where needed at convenient speaking height, about 4.5 feet (137cm) from the finished floor. Handset can be secured directly to the finished wall surface or can be mounted over a single gang electrical 'gem' box or single gang electrical plaster ring.

OUTSIDE STATION(S)

Locate door station(s) at convenient speaking height on exterior wall near entrance. When using the NH201TVA (stand alone) amplifier, all door stations must have the proper speaker and electret condenser microphone installed (model# TE-TT-201)

NH201TVA AMPLIFIER/POWER SUPPLY

The NH201TVA is usually located in a separate equipment location. You can mount the NH201TVA by using the provided plastic 'DIN' rail bracket, or by screwing it to the mounting surface using the holes provided. It must be located away from any source of direct heat or extreme cold and in an accessible location. Keep at least 3 feet (1 meter) away from transformers, AC power wiring, transformers, fluorescent lights, light dimmers and other electrical devices. Protect cable from damage.

Shielded cable should be used if interference is a concern.

DOOR RELEASE

Run 2 conductor #18AWG from the electric door release location to the NH201TVA (or NH201TT) amplifier. If distance is greater than 50 feet, use #16AWG cable. Use a separate cable from the intercom cable, and route away from any intercom wiring.

CONNECTIONS

Before connecting, make certain wires are free from shorts or grounds. Make connections as shown on page 4 and as detailed in the following instructions.

INSIDE HANDSET STATIONS

1. Connect terminals 'I' and 'II' on handset stations to terminals 'I' and 'II' on other handset stations and to terminals 'I' and 'II' on the amplifier.
2. Connect terminal 'S' on each individual handset station to the corresponding push-button at the entry door station, that is used to signal that handset station.
3. Terminals 'Z' and 'K' on each handset station are optional terminals, and are only used if the 'Red Dot' push-button needs to be used to operate an optional function.

DOOR ENTRY STATION

1. Connect speaker/microphone terminals 'L1' and 'L2' on door entry station to terminals 'L1' and 'L2' on the NH201TVA amplifier.
2. Connect speaker/microphone terminals 'M1' and 'M2' on door entry station to terminals 'M1' and 'M2' on the NH201TVA amplifier.

NOTE: The NH201TT amplifier comes factory-wired with the L1,L2,M1 and M2 speaker/microphone connections already installed onto the amplifier.

TRANSFORMER

1. Connect transformer 16VAC terminals to the 16VAC input terminals ('8' and 'II') on the NH201TVA or NH201TT amplifier/power supply. Do not use this transformer to power any other device, not included on this system.
2. Do not plug SS105B transformer into electrical outlet or connect SS106 transformer primary to 117 VAC until entire installation is complete and checked.

DOOR OPENER

1. Connect one wire coming from door opener to amplifier terminal '8'.
2. Connect one wire coming from door opener to amplifier terminal 'O'.

NOTE: use proper gauge wiring to door opener.

NOTE: POLARITY OF AC TYPE DOOR OPENER TERMINALS IS NOT CRITICAL.

FINISH INSTALLATION

1. Install stations on housings. Do not overtighten screws.
2. Install amplifier and accessory devices as needed.
3. Plug SS105B transformer into outlet. If SS106 transformer is used, connect primary to 117 VAC. Observe all local and national electrical codes.

TEST AND CHECKOUT

1. At all inside handset stations, make sure the handsets are hung-up and seated properly on the cradle switch, and that no wires were 'pinched' when handset covers were affixed.
2. Check each unit in the system for operation in accordance with the operating instructions.
3. If feedback occurs between stations, reduce volume. Amplifier volume control is preset at the factory, but may be readjusted, if necessary.

NOTE: The Alpha Communications® warranty is void if this system is installed or used in any manner other than described in this manual.

OPERATING INSTRUCTIONS

OUTSIDE DOOR STATION

TO CALL HANDSET: Push button on outside door station to signal inside handset. An electric buzzer will be heard at the inside handset station. If the electric buzzer has been replaced by the optional model R2007 AlphaTone™ unit, an electronic chime sound will be heard at the handset station.

INSIDE HANDSET STATIONS

TO REPLY: Lift the inside handset off of its cradle and speak in a normal voice. Conversation is full duplex type (simultaneous talk and listen). If satisfied with the identity of the caller, you may depress the 'Key Symbol' push-button to electrically open the entrance door (if so equipped). An AC type door opener will 'buzz' while operating, indicating permission to enter. When conversation is completed, hang-up handset on its cradle.

TROUBLESHOOTING

If the system fails to operate as required, review operating instructions again. If the equipment fails to operate as indicated in the instructions, check the following points:

1. **ENTIRE SYSTEM DEAD:** Check 16VAC at transformer secondary; wiring between transformer and NH201TVA or NH201TT amplifier; connections at amplifier terminals and for 117 VAC at transformer primary.
2. **NO CALL UP BUZZER AT HANDSET:** Check for approx. 16VAC at terminals 'II' and 'S' on handset, when entry station pushbutton is depressed. Temporarily switch handset with one from a functioning location. Check wiring connections at remote handset. Check that wiring inside handset base is not restricting movement of buzzer clapper; temporarily switch handset to another location that is functioning, and try again. Check that entry station pushbutton is making contact, by shorting out the two (2) wires on the back of the button.
3. **NO VOICE ON SYSTEM:** Check volume control (potentiometer) on NH201TVA (or NH201TT) amplifier (in both directions; up and down). Check terminals 'I' and 'II' to handsets. Check speaker/microphone connections at each entry door station. Disconnect terminals 'I' and 'II' on NH201TVA (or NH201TT) system amplifier, and connect a single handset to those terminals. If voice is working, amplifier and entry speaker/microphone are O.K., so check riser wiring. If not, amplifier or speaker/microphone could be faulty. Check by replacement.
4. **UNABLE TO RELEASE DOOR STRIKE:** Check wiring to handset terminals 'I' and 'II'. Temporarily remove door opener wire going to amplifier terminal 'II' and touch to terminal 'O' on amplifier. Check operating voltage of door opener matches output from system amplifier. Check wiring (and gauge) to door opener, from amplifier/power supply. When using a magnetic type lock or other 'fail-safe' type door lock, you should use a reversing relay, such as our model# PK407A for each entrance.
5. **HUM OR BUZZ:** Check system wiring installed too close to power wiring or electrical devices or transformers; check transformer(s) installed too close to control equipment (should be at least three (3) feet away). Wiring is being run next to wiring for other systems and/or devices.
6. **SQUEALING OR HOWLING:** Check amplifier volume control set too high; check for loose speaker/microphone at door entry station(s).
7. **UNABLE TO TALK TO DOOR STATION:** Check terminals 'I' and 'II' going from handsets to amplifier for continuity and shorts, grounds, etc. Check for proper functioning of door entry station speaker. Check for

approx. 50 ohms between terminal 'L1' and 'L2' on speaker microphone (with system wiring disconnected).

- 8. UNABLE TO LISTEN TO DOOR STATION:** Check terminals 'I' and 'II' going from handsets to amplifier for continuity and shorts, grounds, etc. Check for proper functioning of door entry station microphone.

If these checkpoints fail to indicate the problem, there may be an equipment fault. Contact the factory or qualified service representative.

INSTALLING THE R2007 AlphaTone™: When you wish to replace the standard AC buzzer in the HT3001 series handsets with the optional model R2007 AlphaTone™ unit, please follow these instructions: (for HT2001 series handsets see wiring diagram# AWD077).

1. Locate the silver AC buzzer attached to the handset base. Remove the set screw (and keep it for re-use).
2. Gently pull up the two (2) wires from the buzzer that are attached to the internal p.c. board. Carefully slide the wires off of the connecting posts.
3. Install the R2007 AlphaTone™ in place of the buzzer, using the buzzer set-screw.
4. Install the two (2) wires onto the p.c. board, using the same connecting posts that the buzzer used. Polarity does not matter.
5. Position the wires inside the handset base, so they will not get 'pinched' when the cover is placed over the base.
6. Using a small screwdriver, you can change the AlphaTone's sound, by adjusting the built-in potentiometer found on the p.c. board of the R2007.

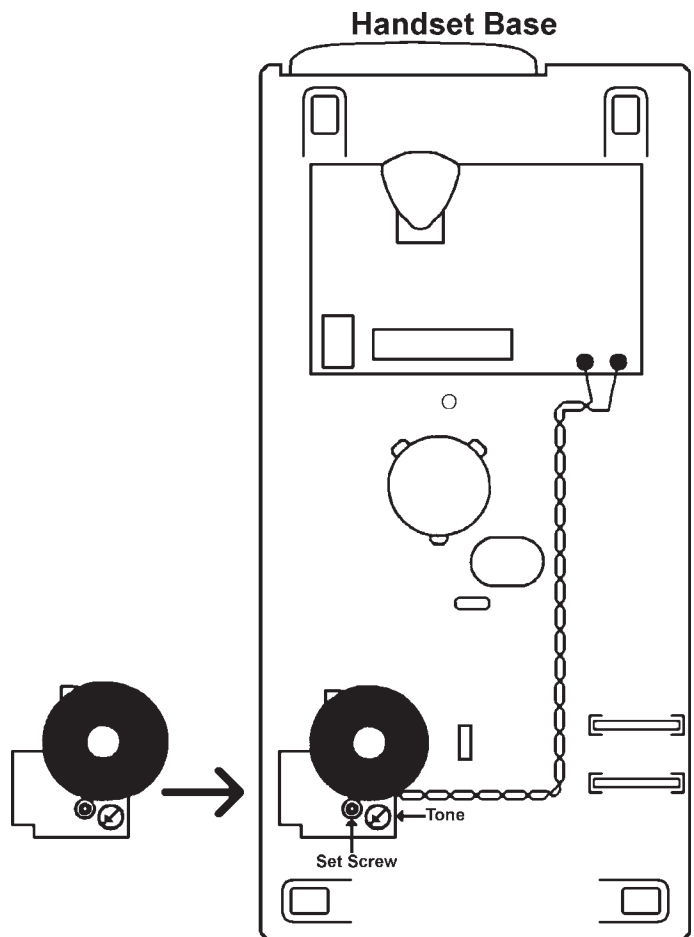

TYPICAL WIRING LAYOUT DIAGRAM FOR A SINGLE ENTRANCE SYSTEM

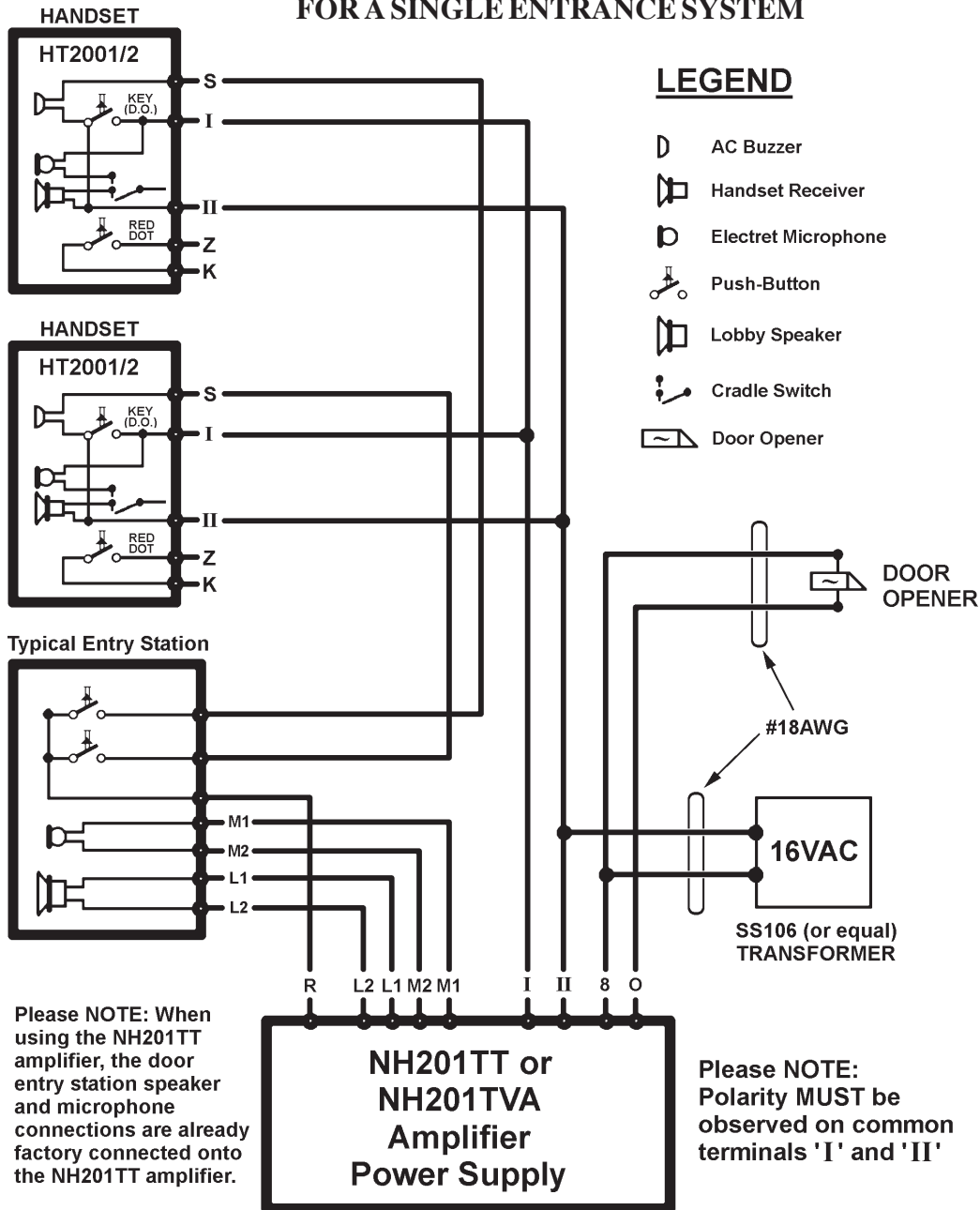

Notes:

1. Use #18AWG wiring to transformer and door opener. All other wiring can be #22AWG.
2. Talk down volume can be adjusted using volume control (potentiometer) on NH201TVA (or NH201TT) amplifier/power supply.
3. When connecting to a magnetic door lock or other 'fail safe' type door lock, use the optional model PK407A specialty relay, for each entrance door lock.
4. If the NH201TVA amplifier is not mounted behind the entry door station, and is mounted remotely, we recommend using shielded cable from the speaker/microphone wires to the NH201TVA amplifier/power supply.
5. Transformer wiring MUST NOT be in same cable as handset wiring!!!
6. Observe all local and national electrical codes.
7. All terminals connections shown may not be in the order that they appear on the equipment.

ALPHA COMMUNICATIONS® • 42 Central Drive • Farmingdale NY 11735-1202
TOLL-FREE TECHNICAL LINE 1-800-666-4800 • Phone: 631-777-5500 • Fax: 631-777-5599
 WEBSITE: www.AlphaCommunications.com • EMAIL: info@alphacommunications.com